

# 2 Tier 900 x 600mm Stock Picking Trolley with Mesh Top (PFR134)

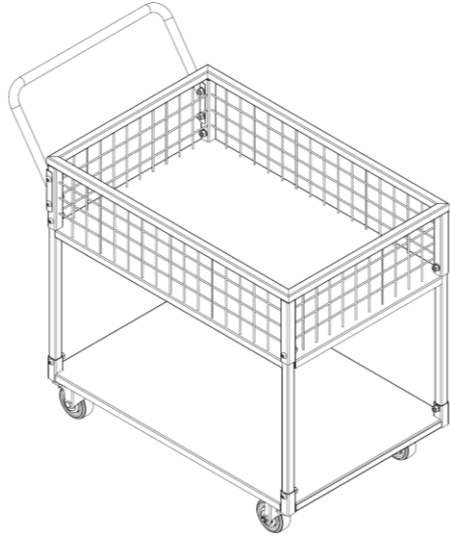

**STEP1:**  
INSTALL CASTERS TO BASE USING M8 HEX HEAD BOLTS

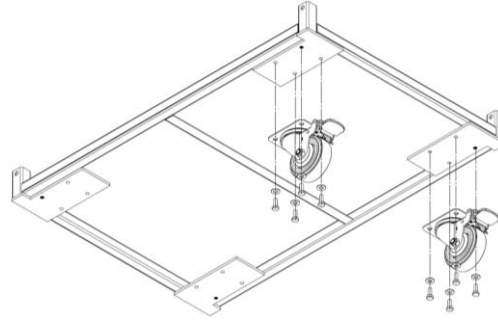

**STEP3:**  
INSERT THE H BRACKET ( NOT THE FRONT AND REAR ONES) INTO THE BASE POND.

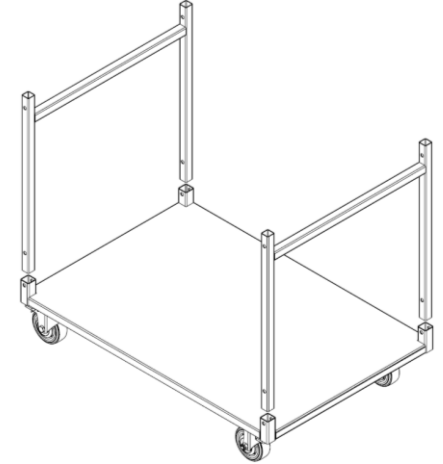

## PART LIST CHECK:

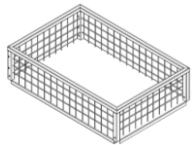

FRONT WALL \*1



HANDLE \*1

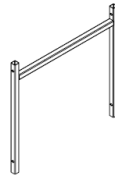

H BRACKET \* 2



CASTER WITH  
BREAK \*2



RIGID CASTER \*2



BASE FRAME \* 1



M10 NYLOC  
NUT \* 12



M10\*50 ROUND  
HEAD BOLT \* 20



M8\*40 HEX  
HEAD BOLT \* 16



M8 FLAT  
WASHER \* 16



M10 FLAT  
WASHER \* 16

**STEP2:**  
INSTALL RIGID CASTERS TO BASE USING M8 HEX HEAD BOLTS

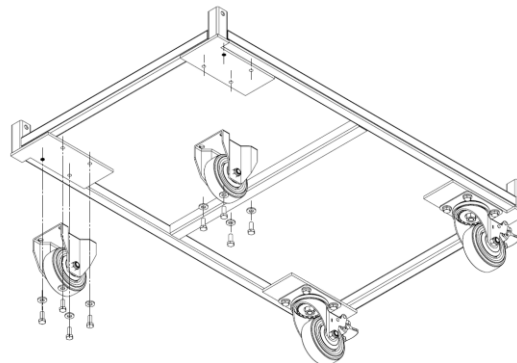

**STEP4:**  
FIX THE BRACKET TO H-BRACKET USING M10 ROUND HEAD BOLTS, WASHERS, AND NUTS. INSERT THE BOLT THROUGH BOTH BRACKETS AND TIGHTEN SECURELY.

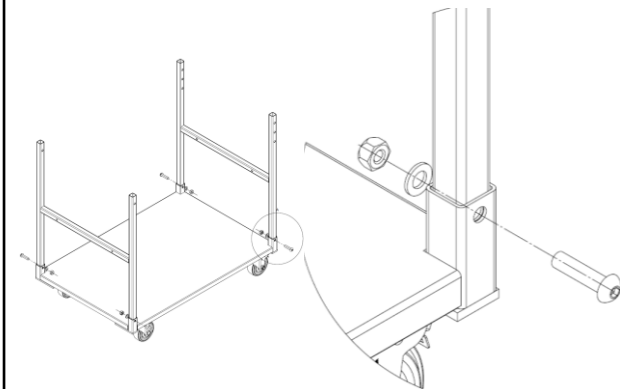

## 2 Tier 900 x 600mm Stock Picking Trolley with Mesh Top (PFR134)

**STEP5:**

INSTALL THE TOP FRAME TO PUT INTO H-BRACKET .

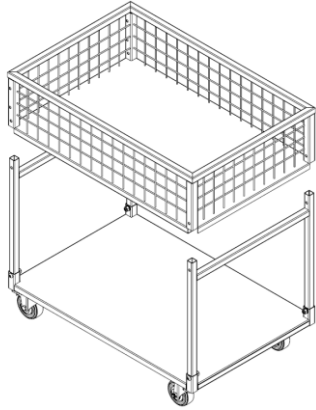

**STEP5:**

INSTALL THE HANDLE TO THE TOP FRAME USING M10 ROUND HEAD BOLTS, WASHERS, AND NUTS. ALIGN THE HANDLE WITH THE MOUNTING HOLES AND TIGHTEN SECURELY.

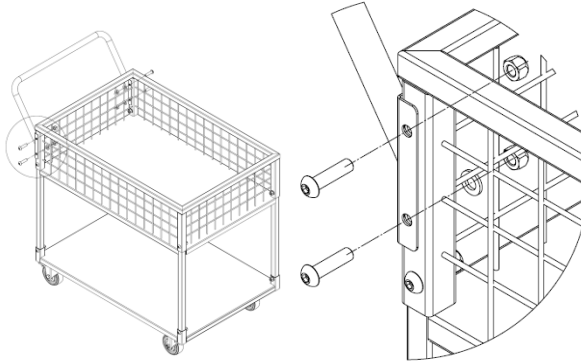

**STEP6:**

USING M10 ROUND HEAD BOLTS, WASHERS, AND NUTS TO SECURE THE TOP FRAME TO THE H-BRACKETS AT EACH CORNER.

