

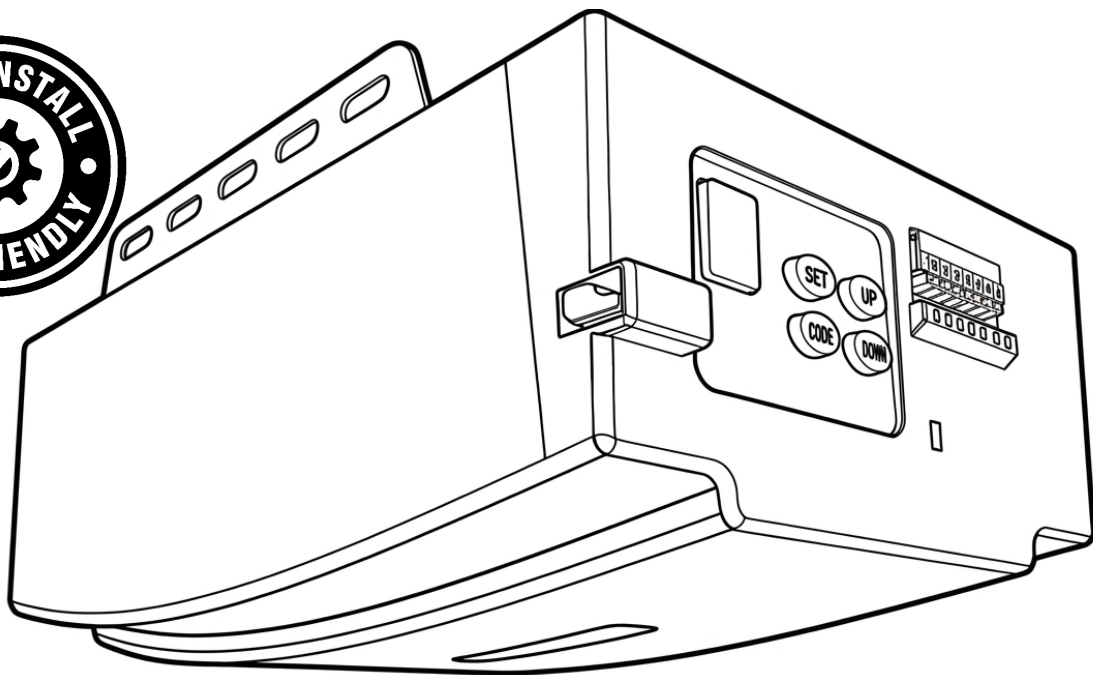

SECTIONAL AND TILTING GARAGE DOOR OPENER

Installation Instructions and User Guide



GDR150



Please read these instructions before installation. Incorrect installation could affect operation.
For more information, please contact your local Richmond Rolling Solutions branch.

TECHNICAL SUPPORT

For installation or troubleshooting assistance visit richmondau.com/gate-motor-support/

Email: gatesupport@richmondau.com

AU: 03 9070 5713

NZ: 0800 61 71 81

International: +613 9551 2233

WARNING: Important safety and legal instructions.
It is important for the safety of persons to follow all instructions.
Save these instructions.

- Failure to comply with the following instructions may result in serious injury or property damage.
- The garage door opener is designed and tested to offer safe service provided it is installed and operated in strict accordance with the instructions in this manual.



These safety alert symbols mean **WARNING: A possible risk to personal safety or property damage exists**



Keep the garage door balanced. Do not let the garage door opener compensate for a binding or sticking garage door. Sticking, binding or unbalanced doors must be repaired before installing this opener



Do not wear rings, watches or loose clothing while installing or servicing a garage door opener. Wear gloves and suitable protective clothing where appropriate.



Frequently examine the door installation. In particular examine cable, springs and mountings for signs of wear, damage or imbalance. Do not use if repair or adjustment is needed since springs and hardware are under extreme tension and a fault can cause serious personal injury.



To avoid serious injury from entanglement, **remove all ropes, chains and locks connected to the garage door** before installing the door opener.



The safety reverse system test is very important. Your garage door **MUST** reverse on contact with a 40 mm obstacle placed on the floor. Failure to properly adjust the opener may result in serious injury from a closing garage door. **Repeat the test once a month and make any necessary adjustments.**



This appliance should not be used by children or persons with reduced physical, sensory or mental capabilities, or a lack of experience & knowledge. Keep remotes out of reach so they cannot be used by such persons.



Automatic Door – The door may operate unexpectedly, do not allow anything to stay in the path or area of the door.

NOTE: If your garage has no service entrance door, we recommend an outside quick release must be installed. This allows manual operation of the garage door from outside in case of power failure.



The opener must not be used on a wicket door (door within a door).



Photocells or IR Beams must be used for all installations where the closing force as measured on the bottom of the door is over 400 N (40 kgf).

Excessive force will interfere with the proper operation of the safety reverse system or damage the garage door. This must also be used on any door that is operated remotely via a Smart Home or 4G system.



Installers must ensure that the doors are installed in a compliant manner as per AS/NZS 60335-2-95. After installation, ensure that the parts of the door do not extend over public footpaths or roads. This opener is designed for automatic operation.



Install the wireless wall control (or any additional wall control) **in a location where the garage door is visible but away from moving parts, at a height of at least 1.5 m and out of the reach of children. Do not allow children to operate push buttons or transmitters.** Serious personal injury from a closing garage door may result from misuse of the opener.



Permanently fasten the warning labels in prominent places, adjacent to wall controls and manual release mechanisms as a reminder of safe operating procedures.



Activate opener only when the door is in full view, free of obstructions and the opener is properly adjusted. No one should enter or leave the garage while the door is in motion.



If the power cable is damaged, it must be replaced by the manufacturer, its service agent or similarly qualified persons in order to avoid hazard.



Disconnect electric power to the garage door opener before performing maintenance or making repairs.



Installation and wiring must be in compliance with your local building and electrical codes. Only use the supplied connector when installing the drive. Installer











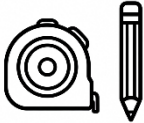
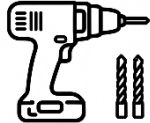

This opener should not be installed in a damp or wet space exposed to weather.

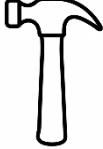
Table of Contents

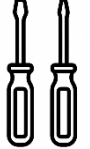
- Tools Required** 4
- Box Contents** 4
- Introduction** 5
 - Suitable Door Types and Dimensions 6
 - Technical Specifications..... 7
 - About Your Opener 8
 - Manual Release..... 10
- Pre-Installation Checks**..... 11
 - Check your installation area 12
 - Check the Door Condition/Operation 13
 - Electrical Requirements 14
- Installation** 15
 - Assemble the segmented rail..... 16
 - Attach the manual release 16
 - Adjust the belt 17
 - Fasten the rail to the opener 17
 - Install a header support (optional)..... 18
 - Mount the wall bracket 19
 - Attach rail to bracket 19
 - Position & hang the opener 20
 - Attach the door bracket & motor arm 21
 - Locate the door on the rail 21
 - Programming Door Travel Limits 22
- Programming, Troubleshooting & Maintenance** 23
 - Programming and Settings..... 25
 - Troubleshooting 33
 - Maintenance 35

Tools Required

					
Ladder	Spirit Level	Tape Measure & Pencil	Power Drill and Drill Bits	Pliers	Shifter
					
Hammer	Hacksaw	Screwdrivers	Shifter	Safety Glasses	Earmuffs

Box Contents

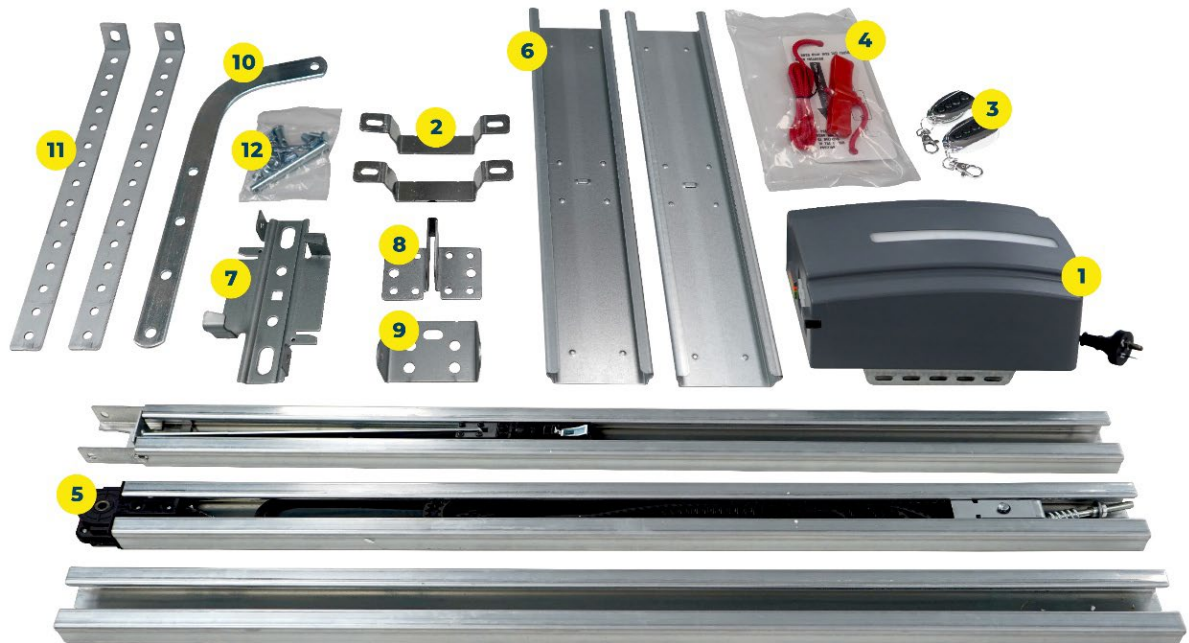

1.	Garage Door Motor (GDR150)	7.	Sectional Rail Support
2.	Motor U-Bracket (2 pieces)	8.	Door Bracket
3.	2x GTR179 Remote Controls (batteries included)	9.	Wall Bracket
4.	Manual Release Cable	10.	Connecting Arm
5.	Sectional Rail & Belt	11.	2x Roof Mounting Brackets
6.	Sectional Rail Joiners	12.	Hardware (bolts, nuts, etc)

Introduction

Suitable Door Types and Dimensions	6
Technical Specifications	7
About Your Opener	8
Manual Release	10

Suitable Door Types and Dimensions

This motor is designed to suit residential spring balanced **Tilt Panel** and **Sectional** doors up to **15.0m²** that include an overhead support rail.

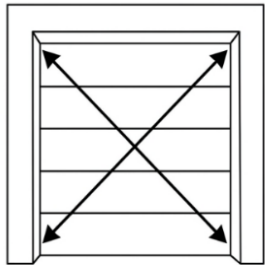

Rated door area: $\leq 15.0\text{m}^2$

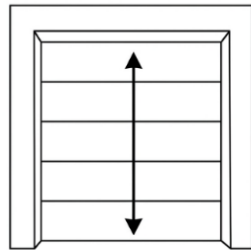

Standard door height: 2400mm
Maximum door height: 3500mm

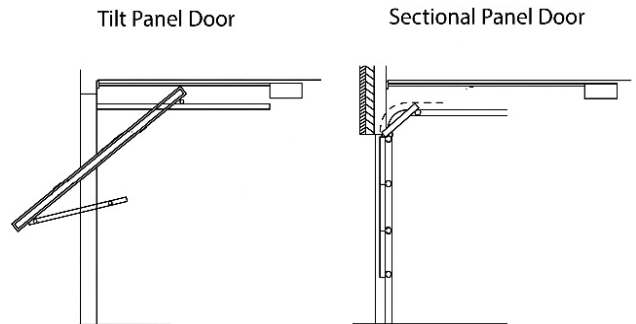

Max Door Height	Max Door Width	Max Door Weight	Max Door Area
2400mm	5600mm	150kg	15.0m ² (height x width)

Completed installation example:

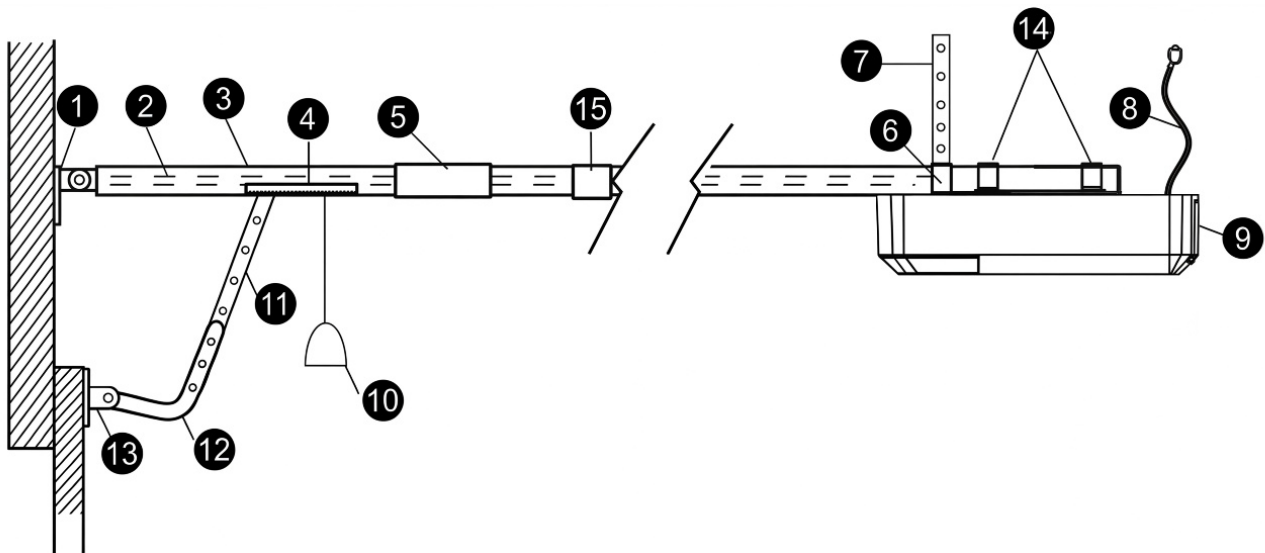

- | | |
|--------------------------|----------------------------------|
| 1. Header Bracket | 9. Opener |
| 2. Belt | 10. Manual release rope & handle |
| 3. Sectional Rail | 11. Straight door arm |
| 4. Trolley | 12. Curved door arm |
| 5. Rail connecting piece | 13. Door bracket |
| 6. Rail bracket | 14. Motor U-Brackets |
| 7. Hanging bracket | 15. Sectional Rail Support |
| 8. Power cord | |

Technical Specifications

Input Voltage	220 - 240V / 110 – 127V, 50-60 Hz
Max. Pull Force	1000 N
Max. Door Area	15.0m ²
Max. Door Weight (Balanced)	100 kg
Max. Door Height	2400 - 3500mm
Drive Mechanism	Chain / Belt
Opening / Closing Speed	160mm / Second
L.E.D.	24V / 15pcs LED bulbs
Limit Setting	Electronic
Transformer	Overload Protection Technology
Radio Frequency	433.92 MHz
Coding Format	Rolling Code (7.38 x 10 ¹⁹ Combinations)
Status Display Transmitter	2 X
Code Storage Capacity	50 Different Codes
Caution Light Terminal	Included
Working Temperature	-40 °C to +50 °C
Safety Protection	Soft start & soft stop, photocell option, caution light option. Impact detection/reversal.
IP Protection Level	IP20

The GDR150 complies to AS/NZS 60335.2.95:2024 standards.

About Your Opener

Opener Layout Explanation

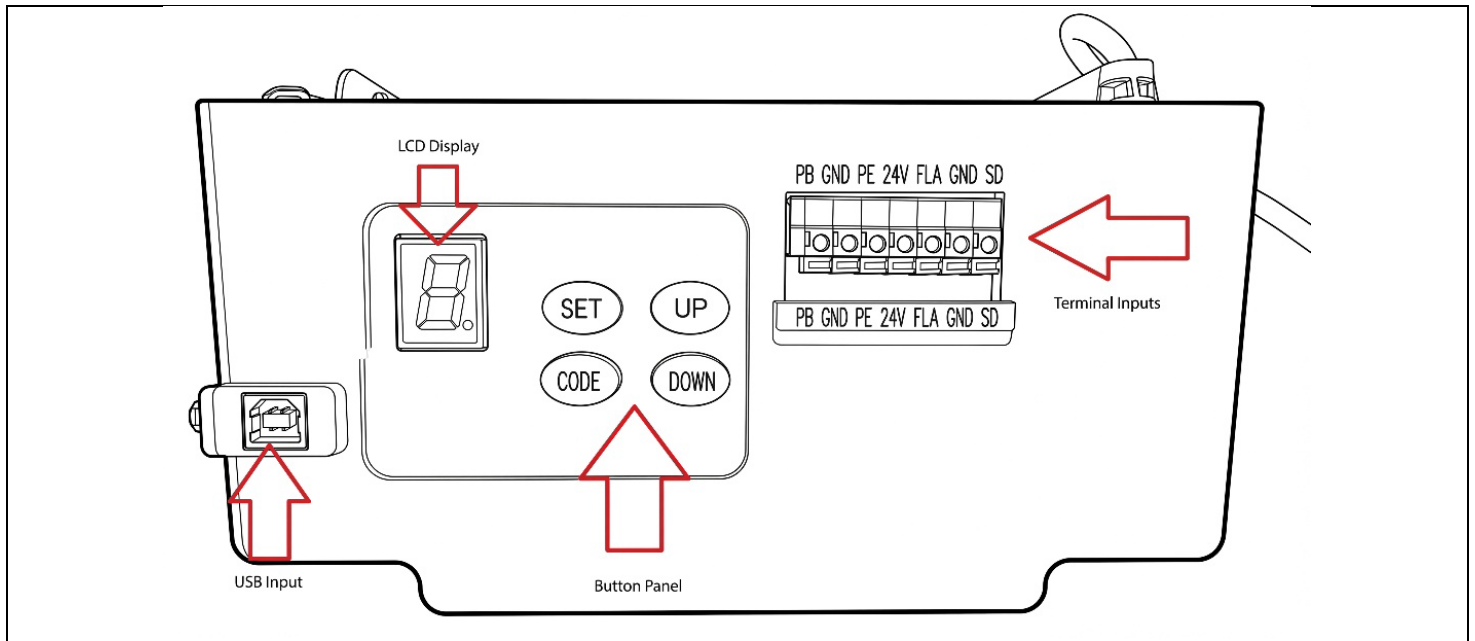



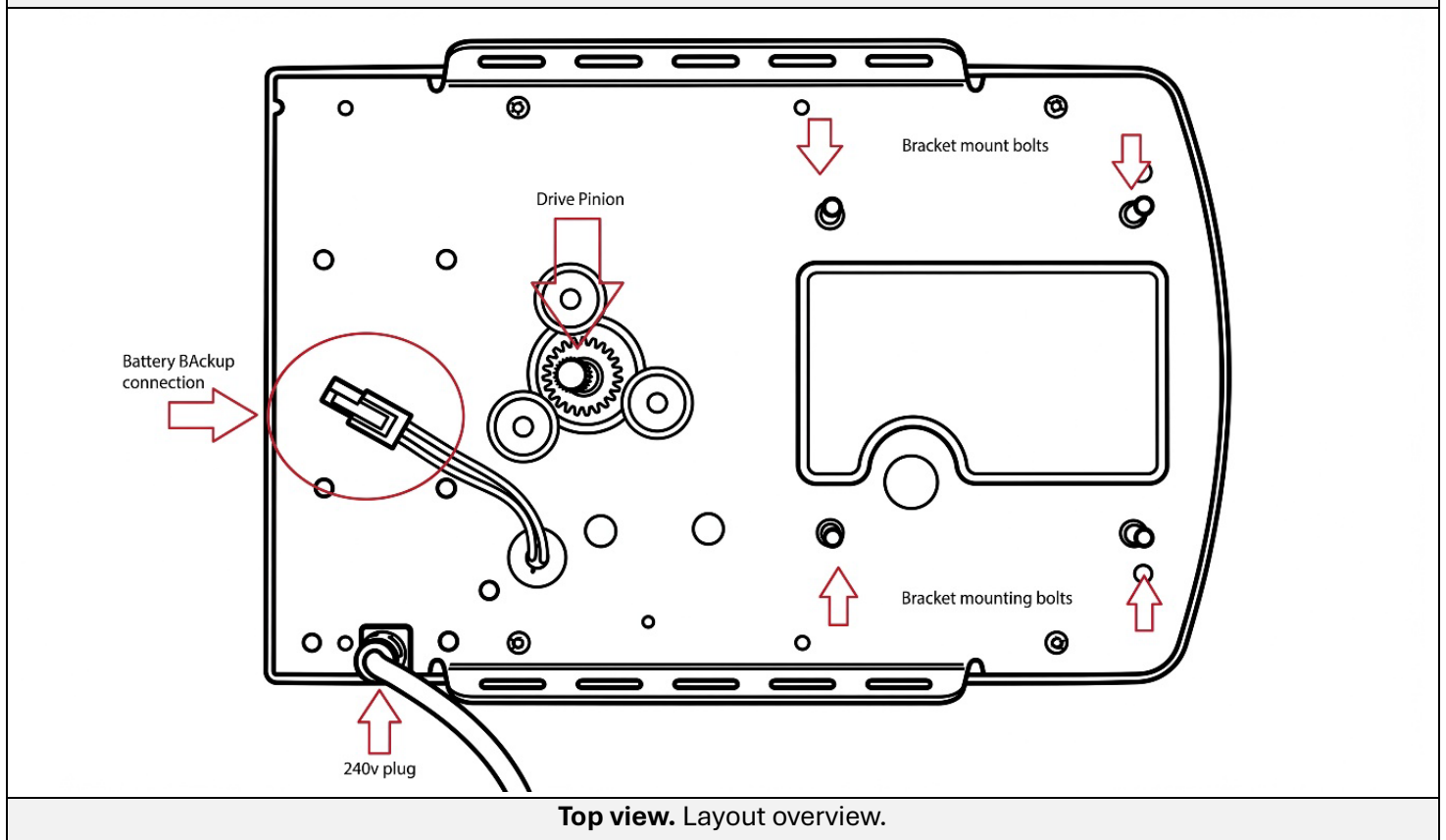

Front view. Layout overview. Detailed explanation in menu settings section.



Top view. Layout overview.

Button Settings Explanation

- Further detail in the programming section.

	SET Button	<p>Short press: Confirms menu settings.</p> <p>Long Press: Enter the menu functions/settings</p>
	CODE Button	<p>In menu settings: short press will exit the current menu and return to standby mode.</p> <p>In standby mode: short press will allow pairing of wireless devices (remotes etc.)</p> <p>Long Press, clears paired wireless devices (remotes etc.)</p>
	UP Button	<p>Short press: Opens the door (after setup is completed)</p> <p>Long Press: Used to change the motor force.</p>
	DOWN Button	<p>Short press: Closes the door (after setup is completed).</p> <p>Long Press: Restores factory settings.</p>

Terminal Explanation

More detailed explanations of each terminal and their functions can be found in the programming section of the manual

PB	N/O Dry Contact Input for Entry/Exit Access Devices - (Push Buttons, Keypads etc.)
GND	COM Dry Contact Input for Entry/Exit Access Devices - (Push Buttons, Keypads etc.) GND Terminal for negative input for powered accessories and photocells
PE	N/O or N/C input for Photocells
24V	DC Positive Input for powered accessories
FLA	Flashing Light terminal for fitting of flashing safety light.
GND	Common terminal for SD & FLA terminals. DC Negative Input for powered accessories.
SD	Secondary Door Input – Allows for fitting of an external door sensor.

Manual Release

The manual release mechanism enables the door to be manually operated during power outages or in an emergency.

- The RED Manual Release cord should be connected to the trolley.
- Tie a secure knot that will not come loose.
- When the opener is installed, the handle must be easily reachable and less than 1.8 metres from the floor. The cord may need to be extended if necessary.
- Ensure the instruction label is fitted to the release cord.

DO NOT USE THE RED HANDLE TO OPEN AND CLOSE THE DOOR.

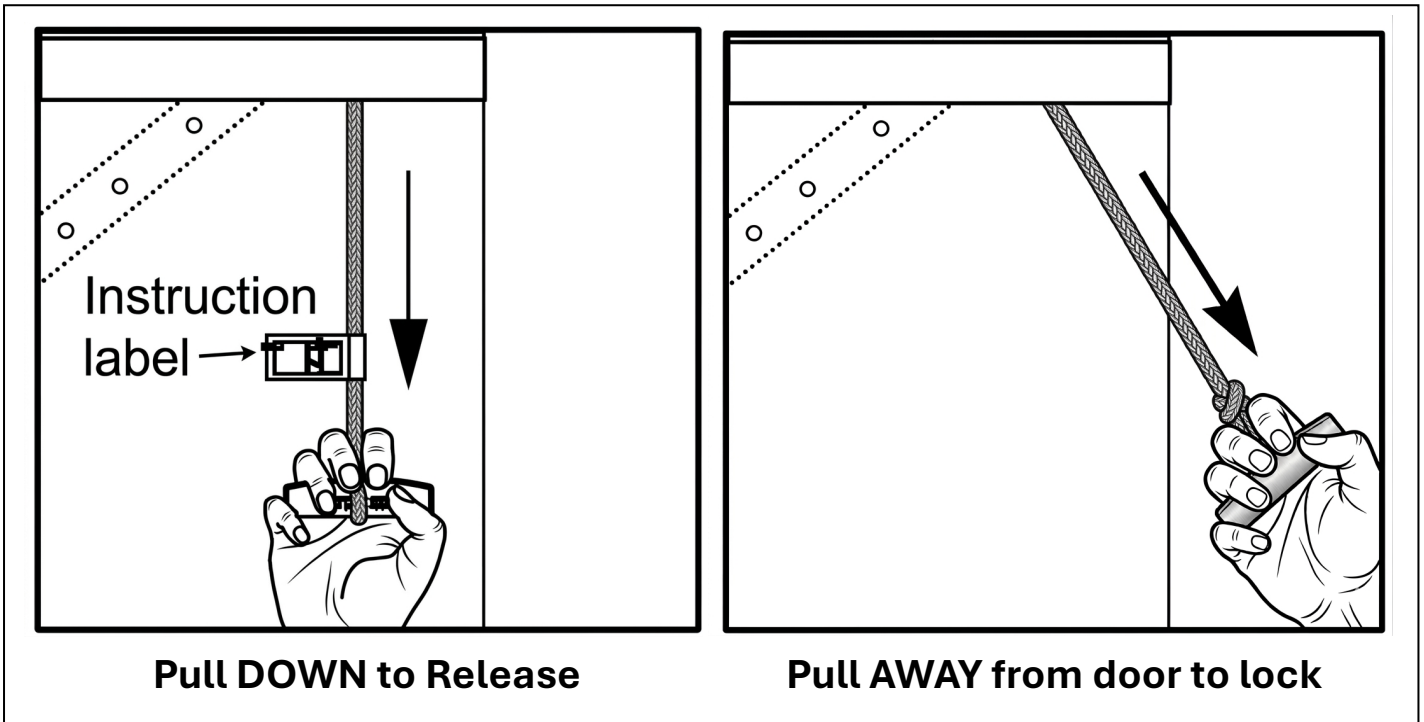

To operate the Manual Release:

The door should be fully closed if possible.

1. **Disengage:** Pull the manual release rope and handle down once to disconnect. This will disengage the trolley, allowing the door to be moved by hand. The door will remain in manual operation until the carriage is re-engaged.
2. **Re-engage:** Pull the manual release cord AWAY from the garage door to re-engage. Operate the door by hand until the trolley reengages with the belt drive.



WARNING! Do not disengage the opener to manual operation with children, persons, or other vehicles within the doorway.



WARNING! Take care when operating the manual release since an open door may fall rapidly due to weak or broken springs or being out of balance.

Pre-Installation Checks

Check your installation area.....	12
Check the Door Condition/Operation	13
Electrical Requirements.....	14

Check your installation area

If you haven't already installed your door, make sure that it is suitable for an automated door.

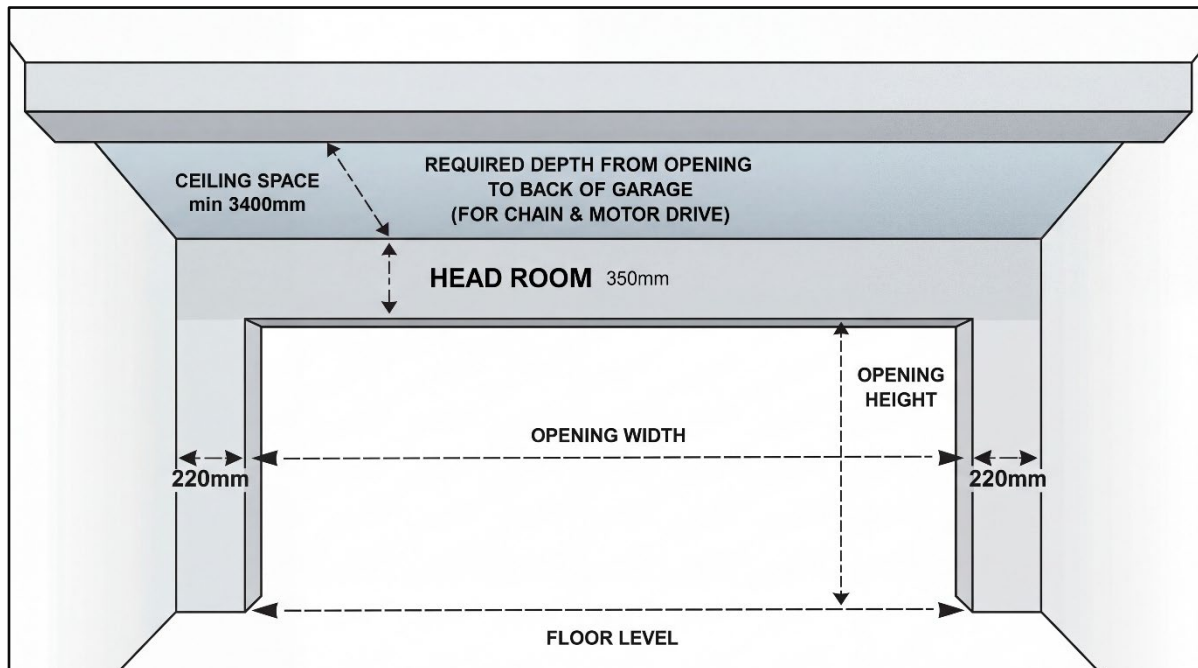

1. Check the area around your door opening. There should be a minimum of 350mm above the door opening, and minimum 220mm either side of the door opening. This allows room for the door (if not already installed). This also allows room for the rail and motor to be mounted above the door.
2. There should be a minimum roof space of 3400mm back from the door opening. This is to allow room for the door to retract and for the motor and rail to be mounted.
3. If a new door is being installed, check that there are sufficient mounting points in the roof for the support rails to be mounted. Check with your door supplier if further information is required.
4. Check that the ceiling has sufficient mounting points for the motor brackets to be mounted. This will support the weight of the opener.
Mounting into plain plaster will not support the motor, a steel or timber frame must be present.

Important note: if no mounting point is available above the door an additional header bracket or brace may need to be installed for mounting the motor door bracket. More details can be found further in the manual.

Check the Door Condition/Operation

Garage door must be able to be lifted and closed easily by hand and without much effort. A well balanced & sprung door is critical for proper installation.

- Raise the door about halfway. Release the door. A well-balanced door should stay in place, supported by the door springs.
- Raise and lower the door slowly by hand to feel for any binding or sticking. IF the door binds or sticks you may need repairs or servicing before fitting your door opener.
- The garage door opener can't compensate for a badly installed garage door and should not be used as a solution for a "hard to open" door.

If the unit is being installed on an existing door, any existing locking devices should be disengaged or removed.

There should be a minimum gap of 50mm between the bottom of the chain drive rail and the top of the garage door at its highest point.

Make sure there is enough room above the door for the rail to be mounted.

If the enclosed area has no other accessible door then a quick release mechanism should be available to allow manual entry from outside.

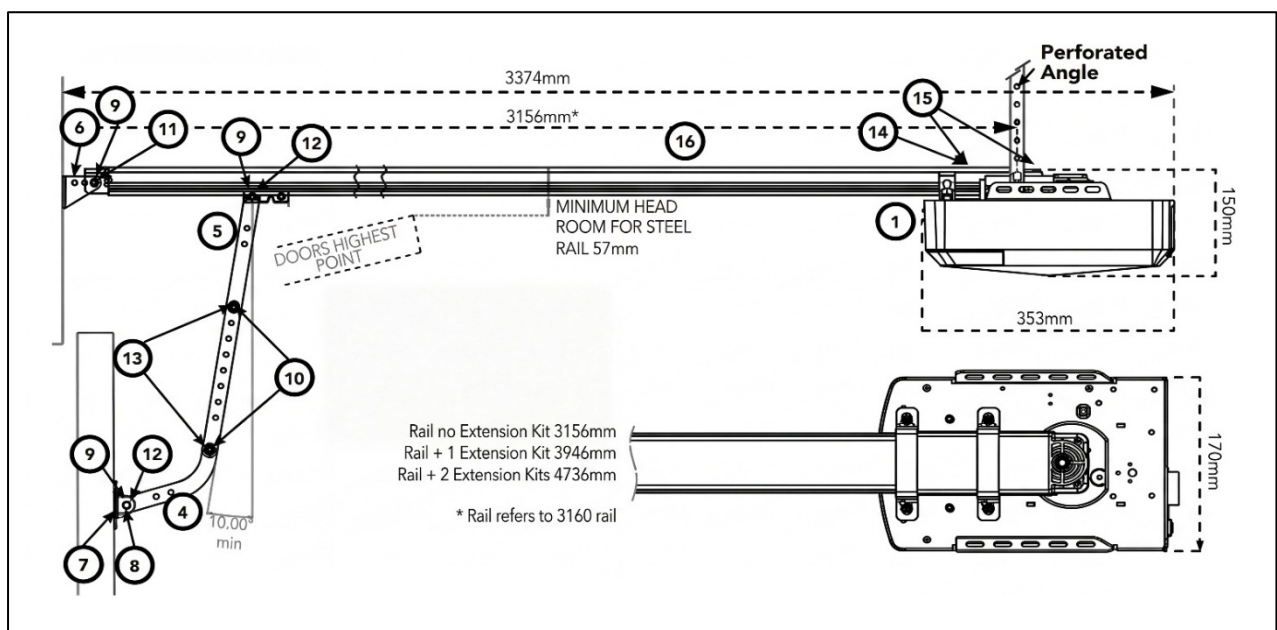
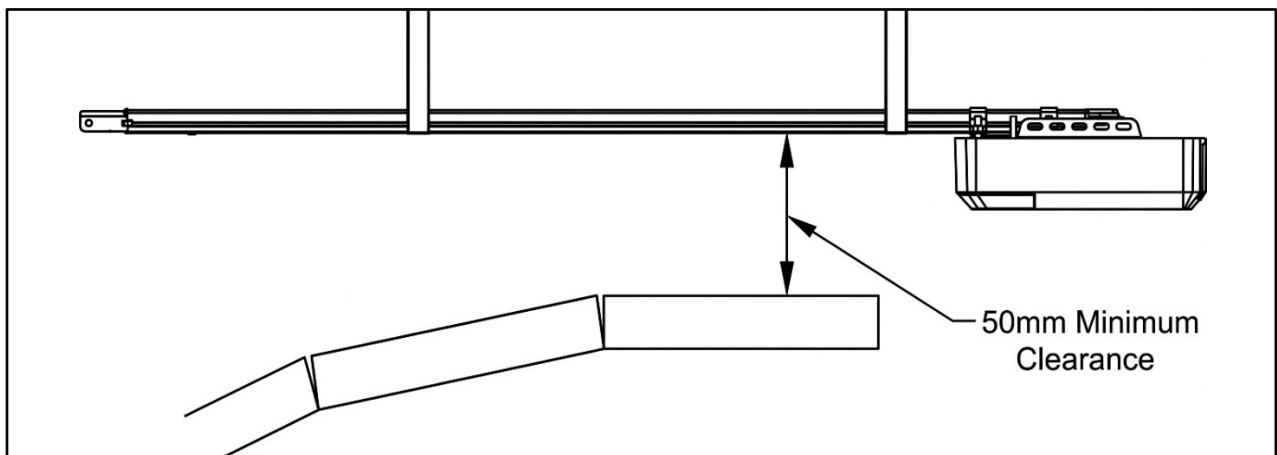

Electrical Requirements

- 240-volt mains power point should be located close to the installation point of your opener.
- All power and accessory cables should be kept away from the operational area of your door.
- A low-voltage power supply option may be available.
 - Contact Richmond Rolling Solutions if you are unable to access a 240-volt mains power point.

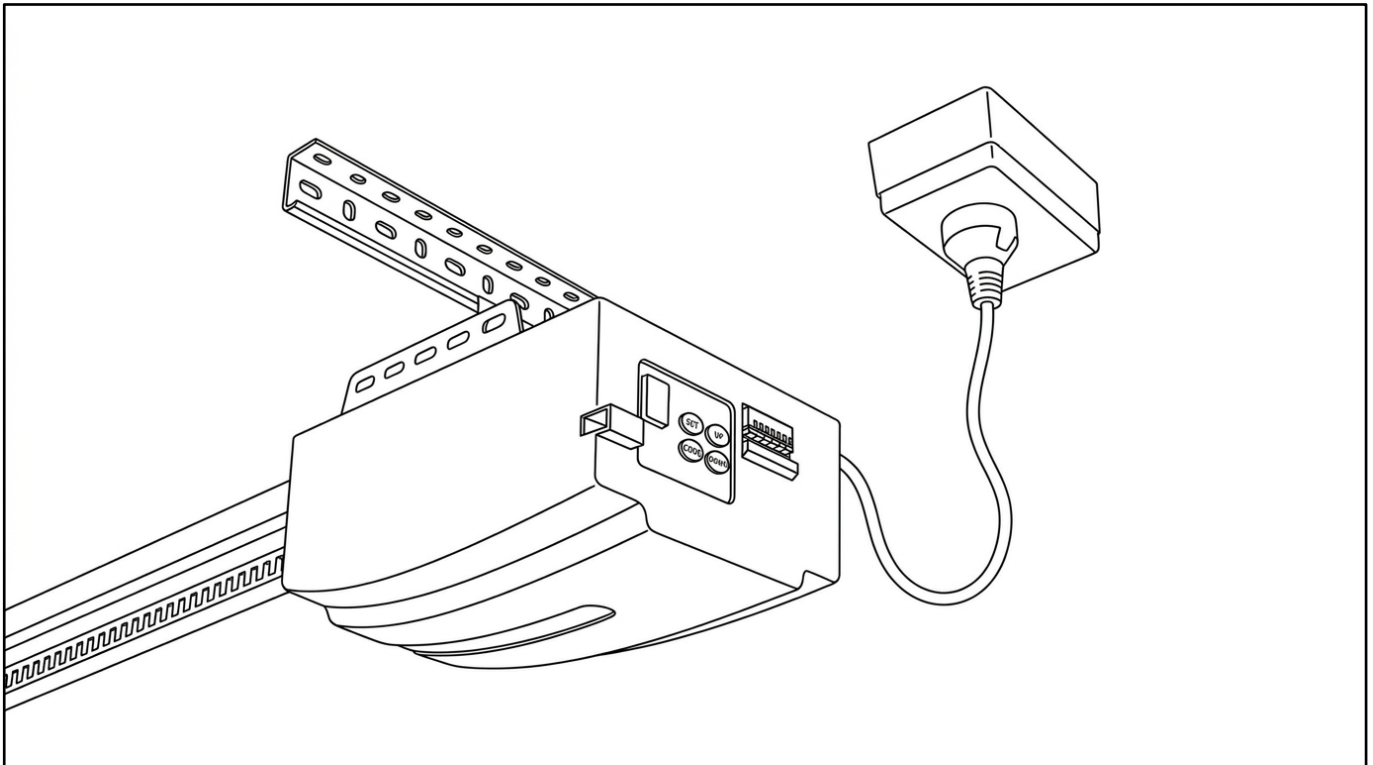

Installation

Assemble the segmented rail	16
Attach the manual release	16
Adjust the belt	17
Fasten the rail to the opener	17
Install a header support (optional).....	18
Mount the wall bracket	19
Attach rail to bracket.....	19
Position & hang the opener	20
Attach the door bracket & motor arm.....	21
Locate the door on the rail.....	21
Programming Door Travel Limits.....	22

Assemble the segmented rail

For easiest assembly, lay the pieces on a flat surface during assembly.

These sections will fit together firmly during installation.

If necessary, use a nylon hammer or use a timber offcut to protect the end of the rail from damage.

1. Start with rail section #1. This will have the drive gear and belt inside.
Pull the bracket and bolt from the end of the rail along with the drive belt so that it is loose.
Leave the drive gear assembled in the end of the rail.
2. Slide a sleeve onto rail section #1 until the notches meet.
3. Slide rail section #2 into the other end of this sleeve until the two rail sections meet in the middle.
4. Slide a sleeve onto rail section #2 until the notches meet.
5. Before starting the final section, place the belt inside the rail pieces.
Slide the bracket and bolt into rail section #3. Check that there are no twists in the belt.
6. Slide rail section #3 into the other end of this sleeve until the two rail sections meet in the middle.
7. Slide the bracket to the end of rail section #3 and push the bolt through the hole in the end.
8. Attach the spring and nut to the bolt at the end of the rail section. This nut is used to tighten the belt inside the rail.

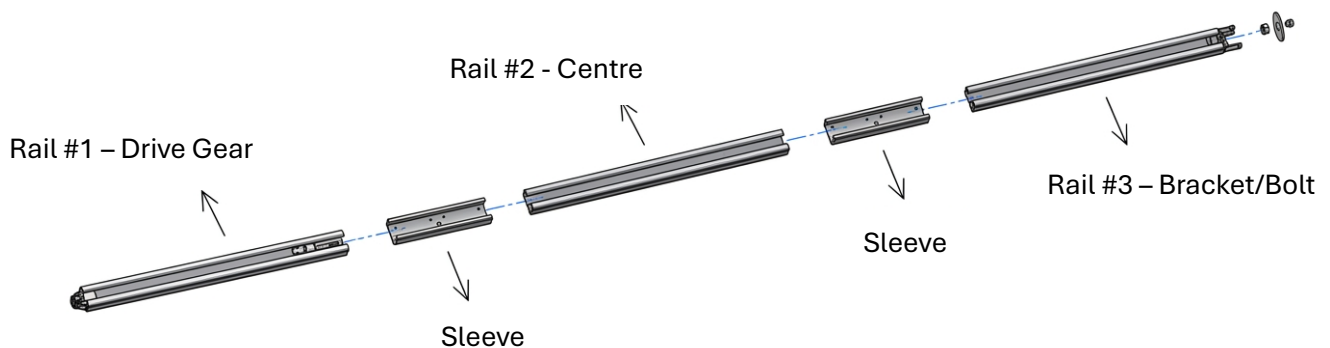

Attach the manual release

Attach the manual release cord to the motor rail trolley.

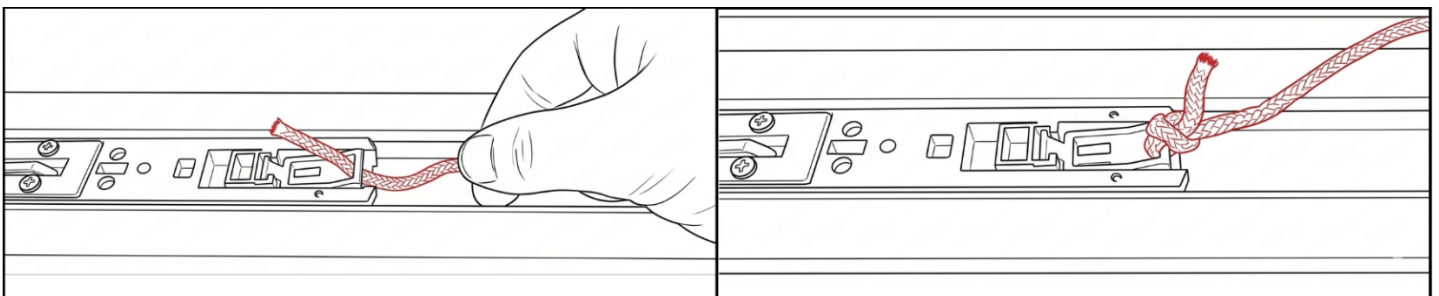

Adjust the belt

1. Turn the nut clockwise until it threads onto the bolt. Continue to tighten until the belt starts to tighten. The nut should not be overtightened and the spring should not be completely compressed. A correctly tightened belt should be allowed to flex approx. 35mm. The remaining spring and belt tension is used to give the belt flex during operation and avoid overloading the opener.

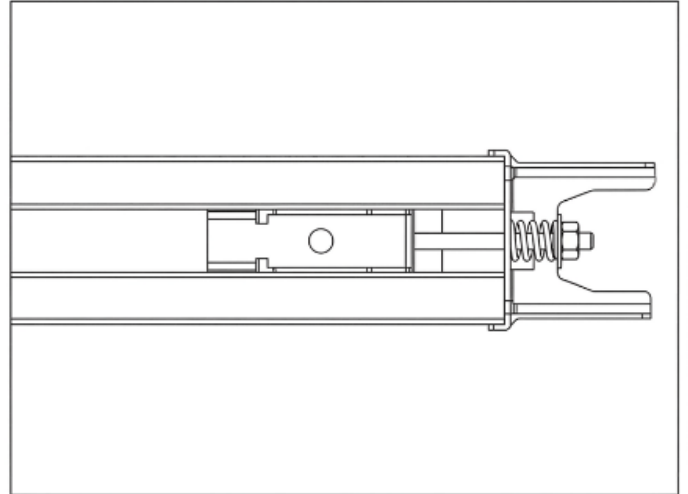
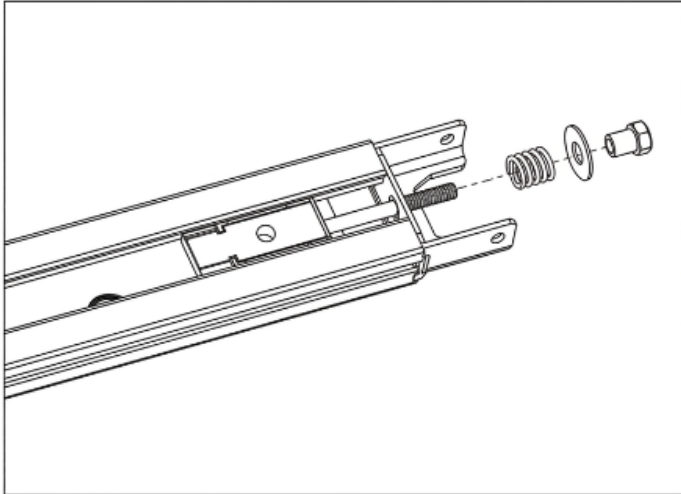

Fasten the rail to the opener

1. Place the opener on the floor on a piece of cardboard or cloth to protect from scratches.
2. Fit the assembled rail onto the drive gear section of the motor. The open section of the rail should be pointing downwards, towards the floor. Push down to fix the rail to the motor.
3. Fit the 2 brackets to secure the rail to the motor.

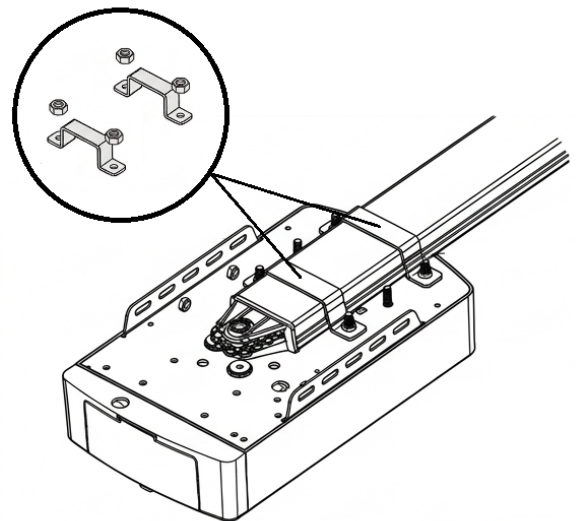

Install a header support (optional)

- The wall bracket must be fixed to a solid structural support.
If a brick wall, or timber/steel frame is available the wall bracket can be mounted directly to this.
- Plaster walls **MUST** have a timber/steel frame behind to be fixed into.
- If the above are not available, a header support must be fitted (image/instructions below).

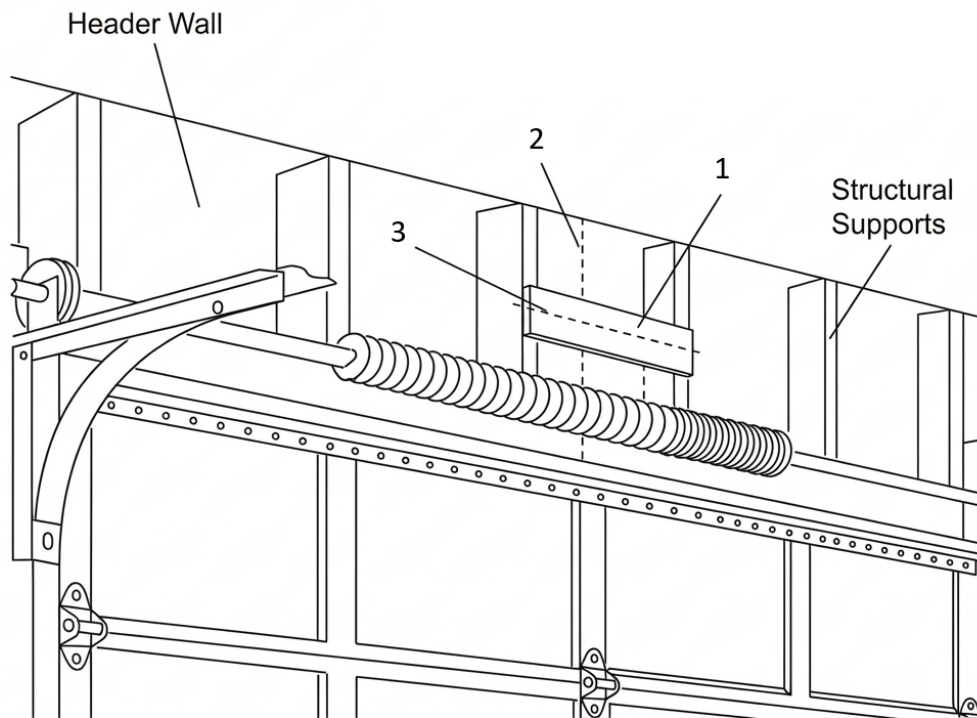

1. The header support will fit across the existing framework to create a central location for your wall bracket to be mounted to.
2. With the door closed, mark the vertical centre line of the garage door. Extend this line onto the header section to make sure you have the found the centre correctly.
3. Open the door to the highest point of travel. This will be different for sectional doors or tilt panel doors. Measure that height. The horizontal centre of your header support should be 50mm above the highest point of travel of your garage door.

Mount the wall bracket

1. With the door closed, mark the vertical centre line of the garage door. Extend this line onto the header section to make sure you have found the centre correctly.
2. Open the door to the highest point of travel. This will be different for sectional doors or tilt panel doors. Measure that height. The horizontal centre of your header support should be 50mm above the highest point of travel of your garage door.
3. Place the wall bracket by hand and mark the holes with a permanent marker.
4. Drill the holes for the fasteners (not supplied) and fasten the wall bracket to the wall.

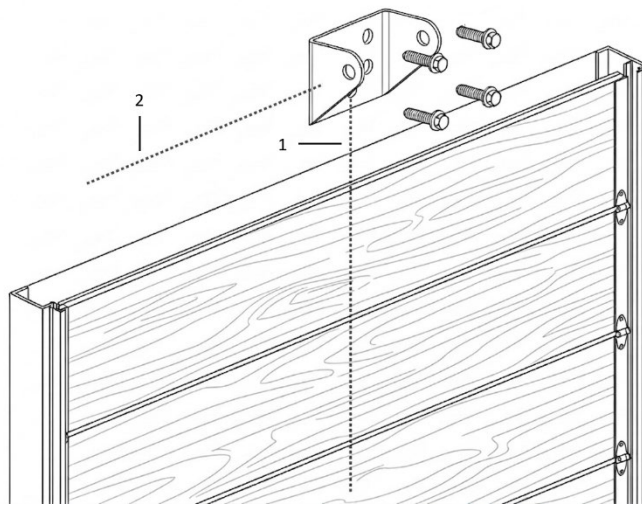

Attach rail to bracket

1. Place the opener in the original packaging for protection. With the opener furthest from the door, lift the drive rail so the rail can be connected to the wall bracket.
2. Line up the bracket and insert the pin through the wall bracket and drive rail holes.
3. Secure with the hairclip pin provided.

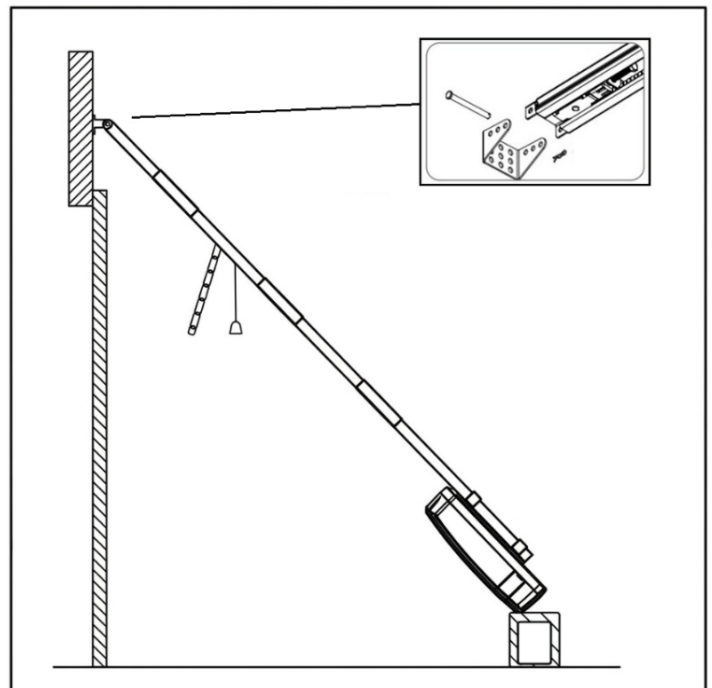

Position & hang the opener

1. Using a ladder, position the motor so that the drive rail is level.
2. Disengage the manual release and manually open the door.
3. Using a spacer at least 50mm thick, check that the rail is clear of the door at it's highest point. The final position of the rail should be relatively parallel to the door panels.
4. Loosely attach the Roof Mounting Brackets to each side of the motor. These brackets can be shortened if necessary.
5. Fix the brackets to the ceiling. (Fasteners not supplied).
Make sure you are fixing into a timber/steel frame.
If necessary, mount a timber block or steel angle to the roof to ensure motor is correctly fixed to the ceiling. (Not supplied).

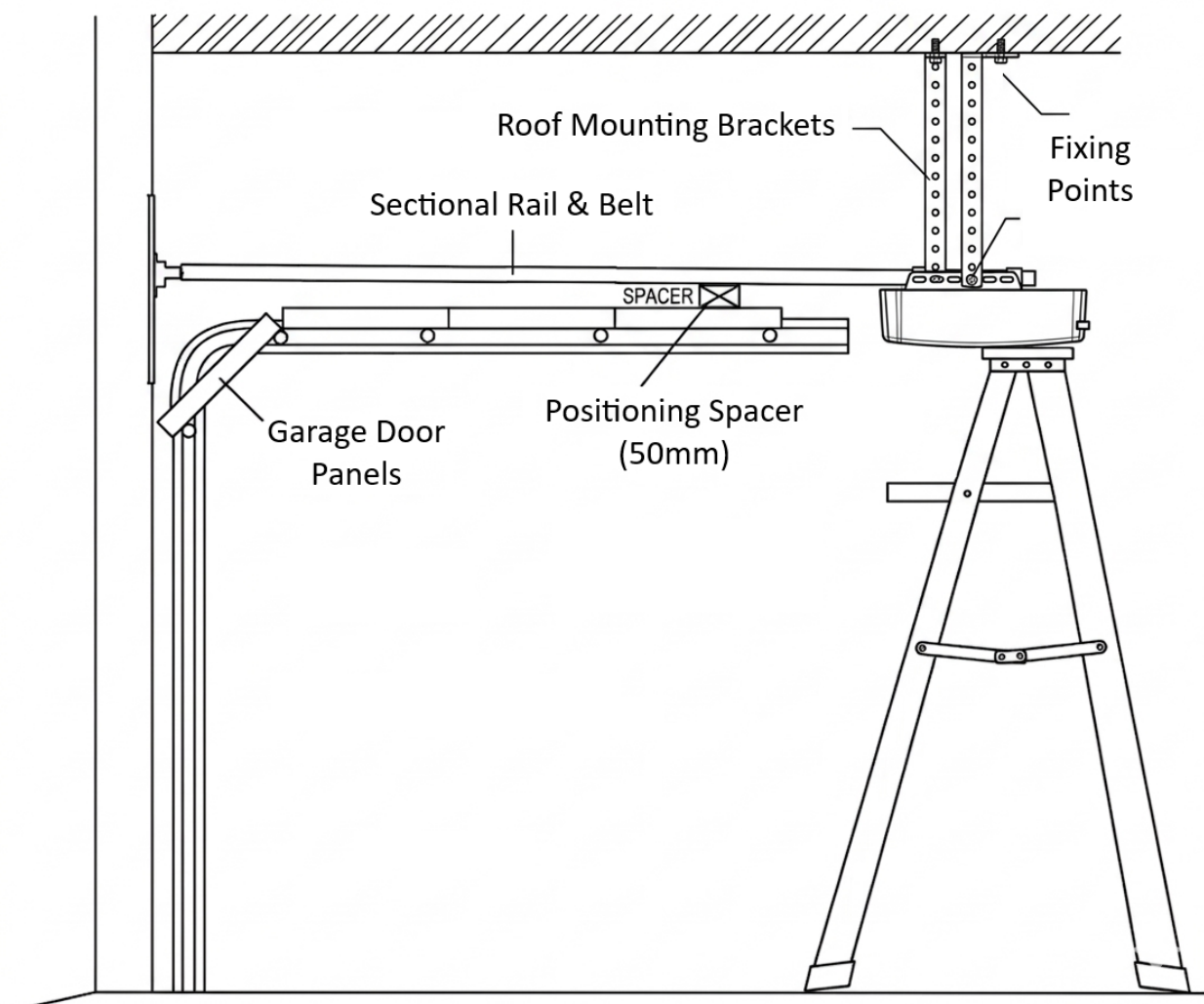

Attach the door bracket & motor arm

1. Close the garage door and fix the door bracket to a structural part of the door as close to the top edge as possible. Make sure the it is located in the centre beneath the rail and wall bracket.
2. Connect the straight arm from the door trolley to the bent arm with the bolts supplied. Position and bolt the arms to the top edge of the door using the bolt supplied.

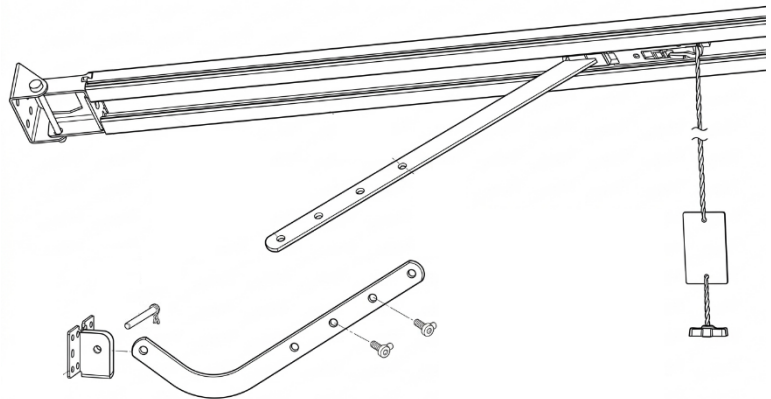
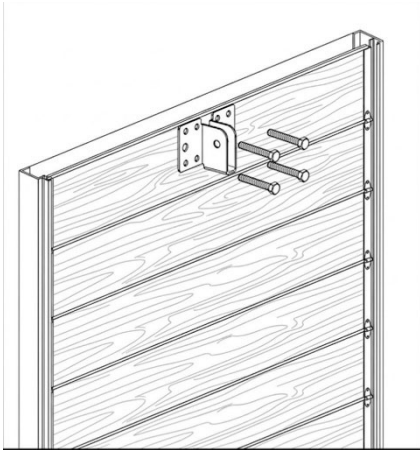

Locate the door on the rail

1. Lock the manual release by pulling the cord away from the garage door.
2. Manually open the garage door slowly until the trolley carriage locks into the trolley connector on the belt.
3. The rail & belt should now hold the door in place firmly.

Programming Door Travel Limits

Set the Open and Close positions of your garage door and your motor will be ready for use.

1. Enter Programming Mode

- **Press and hold** the **SET** button until the display shows “**1**”, then release it.
- **Press** the **SET** button once more. The display will show “**n**” with a dot. The opener is ready to program.

2. Set the Open Position

- **Press and hold** the **UP** button until the door reaches your desired **Open** position. (The dot next to the "n" will disappear).
- **Tip:** Use short presses of the **UP** and **DOWN** buttons to fine-tune the position.
- **Press SET** to save this position. The display will now show “**u**” with a dot.

3. Set the Closed Position

- **Press and hold** the **DOWN** button until the door reaches your desired **Closed** position. (The dot next to the "u" will disappear).
- **Press SET** to save this position. The display will show “**ll**”.

4. Automatic Calibration

- Once confirmed, the door will automatically run a full **Open and Close cycle**. This allows the motor to calculate the travel distance and the force required to move the door safely.

⚠ Important: Check Your Balance Score

After the cycle finishes, a number from **0 to 9** will appear on the display. This represents the door's balance:

- **0** = Perfectly balanced.
- **Lower numbers** are better.
- **Recommendation:** Ensure this number is lower than your "power force" setting. If the number is high, your door springs may need professional adjustment.

⚠ Important: Test the Safety Reverse System

- With the door opened, place an obstacle 40mm high laid flat on the floor under the door. Operate the door in the down (closed) direction. The door should recognise the obstacle and reverse direction until open or partially opened (depending on settings).
- If the door stops on the obstacle and does **NOT** reverse, repeat the Programming Door Travel Limits step.
- Remove the obstacle and run the door through a complete open/close cycle. If the door reaches the closed position and reverses, repeat the Programming Door Travel Limits step.

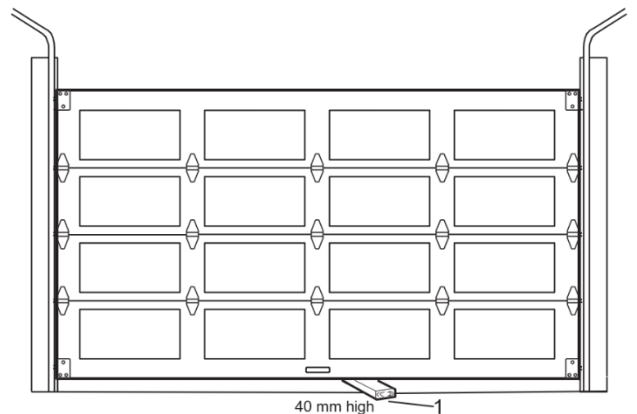

Programming, Troubleshooting & Maintenance

Basic Operation (Standby Mode)	25
Remote Control (Transmitter) Pairing	25
Advanced Settings & Maintenance	25
Programming Door Travel Limits	26
Obstruction Force Adjustment	27
Automatic Closing & Time Setting	28
Photocell (Safety Beam) Settings	28
Automatic Closing Position Detection	29
Adjusting Travel Speed	30
LED Off-Delay Timer Setting	30
Pass Door Switch Configuration	30
Reversal Height Setting	31
Setting the Maintenance Reminder (Cycle Count)	32
Troubleshooting	33
Troubleshooting cont.	34
Maintenance	35

Button	Function
SET	<p>Short Press – Confirm selection when in menu settings</p> <p>Long Press – Enter the menu settings from standby.</p>
CODE	<p>Short Press</p> <ul style="list-style-type: none"> - In the menu settings, short press CODE will exit the current operation and return to standby mode. - In standby mode, short press CODE will allow pairing of wireless devices (remotes, keypads etc.) - Press CODE and a dot will appear in the corner of the LCD screen. While in this mode, pairing of your wireless devices will be allowed. Pairing typically requires two repeated actions. First pairing action may cause the LCD dot to disappear. Second pairing action will cause the LCD dot to flash. The device has now been paired. <p>Long Press</p> <ul style="list-style-type: none"> - Erase all paired wireless devices (remotes, keypads etc.) - Press and hold CODE until a letter C is indicated on the display. All paired devices are now deleted.
UP	<p>Short Press</p> <ul style="list-style-type: none"> - In standby mode, short press UP will open the door. <p>Long Press</p> <ul style="list-style-type: none"> - Increase the motor force of the door opener. - Press and hold the UP button. After 4 seconds it will display a number (0-1-2-3). Default setting is 0. Each number higher will increase the output force of the motor. - 1 = 25% increase - 2 = 50% increase - 3 = 75% increase
DOWN	<p>Short Press</p> <ul style="list-style-type: none"> - In standby mode, short press DOWN will close the door. <p>Long Press</p> <ul style="list-style-type: none"> - In standby mode, long press DOWN will restore the opener back to factory settings. - Press and hold the DOWN button for 4 seconds. The display will scroll and show  - The garage door will reset and restart back in factory settings. - This will also erase any paired devices (remotes, keypads etc.)

Basic Operation (Standby Mode)

- **Open Door:** Short press the **UP** button.
 - **Close Door:** Short press the **DOWN** button.
 - **Stop Door:** Press **any button** while the door is moving to stop it immediately.
 - **Clear Errors:** Short press the **SET** button to clear alarms or error codes and return to the normal display.
-

Remote Control (Transmitter) Pairing

- **Pair a New Remote:** 1. While in standby, short press the **CODE** button. A dot will appear in the corner of the display. 2. Press your desired button on the remote; the dot may disappear. 3. Press the **same remote button** again. The dot will flash, indicating pairing is complete.
 - **Delete All Remotes:** Press and hold the **CODE** button until "C" appears on the display. All stored remotes are now deleted.
 - **Exit Settings:** Short press the **CODE** button at any time to cancel an operation and return to standby.
-

Advanced Settings & Maintenance

- **Enter Menu:** Long press the **SET** button to enter the function settings interface.
- **Adjust Resilience (Force):** 1. Long press the **UP** button for 4 seconds until the display scrolls through **0, 1, and 2**. 2. Select your preferred level: * **0:** Standard setting. * **1:** Increase force by 25%. * **2:** Increase force by 50%.
- **Factory Reset:** 1. Long press the **DOWN** button for 4 seconds until the display shows a reset animation. 2. The opener will restart. 3. **Note:** This resets all limits and configurations. You will need to re-program the door travel, though paired remotes will remain saved.

Programming Door Travel Limits

1. Enter Programming Mode

- **Press and hold** the **SET** button until the display shows “**1**”, then release it.
- **Press** the **SET** button once more. The display will show “**n**” **with a dot**. The opener is now ready to program.

2. Set the Open Position

- **Press and hold** the **UP** button until the door reaches your desired **Open** position. (The dot next to the "n" will disappear).
- **Tip:** Use short presses of the **UP** and **DOWN** buttons to fine-tune the position.
- **Press SET** to save this position. The display will now show “**u**” **with a dot**.

3. Set the Closed Position

- **Press and hold** the **DOWN** button until the door reaches your desired **Closed** position. (The dot next to the "u" will disappear).
- **Press SET** to save this position. The display will show “**ll**”.

4. Automatic Calibration

- Once confirmed, the door will automatically run a full **Open and Close cycle**. This allows the motor to calculate the travel distance and the force required to move the door safely.

Important: Check Your Balance Score

After the cycle finishes, a number from **0 to 9** will appear on the display. This represents the door's balance:

- **0** = Perfectly balanced.
- **Lower numbers** are better.
- **Recommendation:** Ensure this number is lower than your "power force" setting. If the number is high, your door springs may need professional adjustment.

Important: Test the Safety Reverse System

- With the door opened, place an obstacle 40mm high laid flat on the floor under the door. Operate the door in the down (closed) direction. The door should recognise the obstacle and reverse direction until open or partially opened (depending on settings).
- If the door stops on the obstacle and does NOT reverse, repeat the Programming Door Travel Limits step.
- Remove the obstacle and run the door through a complete open/close cycle. If the door reaches the closed position and reverses, repeat the Programming Door Travel Limits step.
- **NOTE:** This test should be performed monthly.

Obstruction Force Adjustment

CAUTION: This force is set automatically during initial programming. Manual adjustment is usually not required. The factory default setting is **3**.

Step 1: Enter the Settings Menu

- Press and hold the **SET** button until the number **1** appears on the display.
- Press the **UP** button until the display changes to **2**.
- Release the button to enter the Force Adjustment function.

Step 2: Enter Adjustment Mode

- Press the **SET** button again.
- The display will show a **3** with a flashing dot, indicating you are now in adjustment mode.

Step 3: Adjust the Force

- Press **UP** to increase the force.
- Press **DOWN** to decrease the force.
- **Range:** The minimum setting is **1** and the maximum is **5**.

Step 4: Save and Exit

- Press the **SET** button to confirm your selection.
- The unit will automatically return to standby mode and display "||".

Automatic Closing & Time Setting

⚠ SAFETY FIRST: The auto-close feature will not operate without **Safety Photo Beams** fitted.

- Garage openers that operate remotely outside of line of sight **MUST** have **Safety Photo Beams** fitted.
- Auto-close will not operate if Safety Photo Beams or a similar safety device have not been installed.

Step-by-Step Instructions

1. **Enter Menu Mode:** Press and hold the **SET** button until the display shows **"1"**.
2. **Select Function 4:** Press the **UP** button until the display changes to **"4"**, then release.
3. **Enter Adjustment Mode:** Press **SET** again. You will see a flashing **"0"** on the display.
4. **Set the Delay Time:** Use the **UP** or **DOWN** buttons to choose a number from **0 to 9**.
 - The time is calculated in 15-second increments (15 \times N).
 - **0** = Auto-close is OFF (Factory Default).
 - **9** = Maximum delay (135 seconds).
5. **Save & Exit:** Press **SET** to confirm. The unit will return to standby mode and display **"||"**.

Quick Reference Table

Display Setting	Delay Time
0	OFF
1	15 Seconds
2	30 Seconds
...	...
9	135 Seconds

Photocell (Safety Beam) Settings

Important: If you do not have safety beams installed, this setting **must** be set to **0**. If it is set to 1 without beams, the door will not close and the display will show **"r"**.

Step-by-Step Configuration

1. **Enter Menu:** Press and hold the **SET** button until the display shows **"1"**.
2. **Select Function:** Press the **UP** button repeatedly until the display shows **"d"**, then release.
3. **Enter Adjustment Mode:** Press **SET** again. You will see a **"0"** with a flashing dot.
4. **Toggle Setting:** Use the **UP** or **DOWN** buttons to choose your setting:
 - **0:** Photocell OFF (Factory Default)
 - **1:** Photocell ON
5. **Save & Exit:** Press **SET** to confirm. The unit will return to standby mode and display **"||"**.

Wiring Note

Ensure your photocell is correctly wired to the accessory terminals using **Normally Closed (NC)** contacts.

Automatic Closing Position Detection

Step 1: Enter the Settings Menu

- **Press and hold** the **SET** button until the number "1" appears on the display.
- Press the **UP** button repeatedly until the display changes to "5".
- **Release** the button to enter the Closing Condition menu.

Step 2: Select Adjustment Mode

- Press the **SET** button once.
- A "1" with a **flashing dot** will appear, indicating you are now in adjustment mode.

Step 3: Choose Your Closing Preference

Use the **UP** or **DOWN** buttons to toggle between two options:

Option	Meaning
"1"	Standard (Factory Default): The door will only auto-close if it is fully open.
"2"	Variable: The door will auto-close from any position.

Note: The door will only trigger an auto-close if it was moving **upward** (opening) before it stopped. It will not auto-close if you stop it while it is already moving downward.

Step 4: Save and Exit

- Press the **SET** button to confirm your choice.
- The unit will save your settings and return to standby mode (the display will show "II").

Adjusting Travel Speed

⚠ CAUTION: Changing the speed will **delete** your previous travel limits. You must re-program your travel limits after adjusting the speed for the unit to function correctly.

Step-by-Step Instructions

1. **Enter Menu 3:** Press and hold the **SET** button until the display shows "1". Press the **UP** button until the display changes to "3", then release.
2. **Enter Speed Mode:** Press the **SET** button again. The display will show a flashing letter "**A**" to indicate you are in speed adjustment mode.
3. **Choose Your Speed:** Use the **UP** and **DOWN** buttons to select your preferred speed:
 - **8:** 80% speed
 - **A:** 100% (Full speed)
4. **Save and Exit:** Press the **SET** button to confirm. The unit will save your settings, return to standby mode, and display "||".

Note: The device is set to full speed (**A**) by default from the factory.

LED Off-Delay Timer Setting

Use these steps to adjust how long the LED stays on (from 1 to 9 minutes) before turning off automatically.

- **Step A: Enter Function Menu** Press and hold the **SET** button until "1" appears. Use the **UP** button to scroll to "6," then release.
- **Step B: Access Delay Adjustment** Press **SET** again. The display will show a flashing "3" (the factory default), indicating you are now in adjustment mode.
- **Step C: Set the Time** Use the **UP** or **DOWN** buttons to choose a value between **1 and 9**.

Note: Each number represents one minute (e.g., 5 = 5 minutes). The maximum setting is 9 minutes.

- **Step D: Save and Exit** Press **SET** to confirm your choice. The unit will return to standby mode and display "||".

Pass Door Switch Configuration

1. **Enter Settings Mode:** Press and hold the **SET** button until "1" appears on the display.
2. **Select Function:** Press the **UP** button until "C" is displayed, then release.
3. **Access Adjustment:** Press the **SET** button again. The display will show a flashing "0" to indicate you are in the pass door adjustment mode.
4. **Set Switch Type:** Use the **UP** or **DOWN** buttons to select your required setting:
 - **0:** Normally Open (Standard factory setting)
 - **1:** Normally Closed

Confirm and Exit: Press the **SET** button to save your selection. The unit will automatically return to standby and display "||".

Reversal Height Setting

This setting determines how far the door opens back up if it hits an obstruction while closing.

Step 1: Enter Programming Mode

- **Press and hold** the **SET** button until the display shows **"1"**.
- **Press** the **UP** button repeatedly until the display shows **"7"**.
- **Release** the button to enter the function menu.

Step 2: Access the Adjustment Mode

- **Press** the **SET** button once.
- The display will show **"0"** with a flashing dot, indicating you are now in the adjustment mode.

Step 3: Set the Reversal Height

Use the **UP** or **DOWN** buttons to select a value from **0 to 9**:

- **Setting "0"**: The door will rebound all the way back to the fully open position (Factory Default).
- **Settings "1–9"**: The door will rebound to a specific portion of its travel (e.g., "1" is 1/10th of the way up; "5" is halfway up).

Step 4: Save and Exit

- **Press** the **SET** button to confirm your selection.
- The unit will save the setting and return to standby mode, displaying **"II"**.

Quick Tip: Most people prefer to leave this at **"0"** so the garage is completely cleared if the door hits an object, but **"1–9"** is useful if you have a very high ceiling and only want a partial reversal.

Setting the Maintenance Reminder (Cycle Count)

Follow these steps to set a reminder for your garage door's next service based on how many times it opens and closes.

1. Enter the Settings Menu

- **Press and hold** the **SET** button until the number **"1"** appears.
- **Press** the **UP** button repeatedly until the letter **"E"** appears.
- **Release** the button to enter the maintenance function.

2. Access Adjustment Mode

- **Press SET** once more. You are now in adjustment mode.
- A **"0"** with a flashing dot will appear on the display.

3. Select Your Cycle Limit

Use the **UP** or **DOWN** buttons to choose your preferred maintenance interval. Each number represents the total cycles (open/close) before the alarm triggers:

Setting	Total Cycles	Alarm Behavior
0	Off	No maintenance alarm (Factory Default).
1	1,000	LED flashes 10x and "t" appears on display.
2	2,000	LED flashes 10x and "t" appears on display.
3	3,000	LED flashes 10x and "t" appears on display.
4	4,000	LED flashes 10x and "t" appears on display.
5	5,000	LED flashes 10x and "t" appears on display.

4. Save and Exit

- **Press SET** to confirm your choice.
- The unit will return to standby mode automatically, showing **"II"** on the display.



Important Notes

- **The "t" Warning:** If the LED flashes 10 times and a **"t"** appears, your door has reached its cycle limit or may be out of balance. **Perform maintenance immediately.**
- **After Service:** Once maintenance is complete, you should **"Check"** the status or **"Re-learn"** the travel limits to clear the alert.

Troubleshooting

Fault appearance	Fault cause	Solutions
The opener is not operating. LCD screen is not lit	1. Power supply 2. Plug wire is loosing	1. Check the power plug is connected and turned on. 2. Check the home fuses and safety switches.
The door does not recognise position.	System error	Re-set the door travel limits.
Digital display shows 	Door only travels a short distance, or will continuously run.	Re-set the door travel limits.
Digital display shows  Opener does not work or stops working	Unstable voltage or door out of balance	1. Check the power supply. 2. Check the door operation manually, and adjust/repair if necessary.
Opener is not working Digital display shows 	Fail to learn the up and down door travel limits.	Learn "UP" and "DOWN" limit traveling again follow the manual
LED is always on	The control panel is broken or the power supply board is broken	Replace the control board or power board. *Must be performed by a licensed technician/electrician. Contact Richmond Rolling Solutions for assistance.
When operating the door, opener stops automatically after running 10cm Digital display 	Hall sensor wire is loosed or damaged	Open the cover, check the Hall sensor wire, re-plug or replace. *Must be performed by a licensed technician/electrician. Contact Richmond Rolling Solutions for assistance.
Opener does not work. Hear the relay 'kaka' sound Digital display 	The wire between gear motor and board may be loose.	Open the cover and check the wire between gear motor and board. *Must be performed by a licensed technician/electrician. Contact Richmond Rolling Solutions for assistance.
Opener stops automatically after running 10cm Digital display 	The wire between gear motor and board is connected backwards.	Power off firstly, open the cover and reverse the plug wire between gear motor and board. Re-set limit traveling. *Must be performed by a licensed technician/electrician. Contact Richmond Rolling Solutions for assistance.
Door will only move UP. Does not work in the DOWN direction. Digital display 	Photocell function has been triggered, Or the photocell has not been connected with the setting turned ON.	Turn off the photocell function off if there is no photocell device connected. (Refer to the instruction manual) Check if the photocell is connected correctly, or if there is any obstruction between the photocell.

Troubleshooting cont.

The door is fully open, automatically closes after some time LED lights flash 4 times	Automatic closing function is turned on	Set the automatic closing time, or turn off the automatic closing function. (Refer to the instruction manual)
When the door stops, the caution light is always on.	The power board may be damaged.	Replace the power board *Must be performed by a licensed technician/electrician. Contact Richmond Rolling Solutions for assistance.
LED lights do not work	1. The LED wire has become unplugged. 2. The LED is broken 3. The circuit board may be damaged.	1. Check the LED wire 2. Replace the LED 3. Replace the circuit board *Must be performed by a licensed technician/electrician. Contact Richmond Rolling Solutions for assistance.
Door automatically reverses to the upper limit before completely closing.	In operation with automatic reverse function The door is not installed correctly An obstruction has been detected.	1. Check the block position of the door and re-set the limit traveling 2. Increased force number for automatic reverse
Door automatically stops while opening	In operation with automatic protect function when obstruction is detected The door is not installed correctly There is some block on its moving	1. Check the block position of the door and re-set the limit traveling 2. Increased force number for automatic reverse
The remote control cannot be used or the operation distance is short	1. Flat battery 2. Antenna is loosed or not well extended 3. Interference around nearby	1. Replace new battery 2. Extended the antenna on the opener 3. Get rid of interference
Cannot code in the new remotes	New remote control is not compatible with opener	Choose our remote control only
Digital display 	Stored remote code is full	Delete all stored codes (Refer the instruction manual)
Standby, Digital display 	Door in door function effects	Check the door in door switch
The opener is working while the door is not moving	Motor shaft sleeve worn	Replace the motor shaft sleeve
The battery do not supply power	1. Flat battery 2. The battery wire is plugged inversely 3. The battery wire is broken	1. Charge the battery 2. Open the cover, check "+" "-" of the battery 3. Replace the battery wire
Other abnormal issues	External devices is not compatible with the opener	Remove all the external devices. If the abnormal issues still exist, replace the circuit board
Digital display 	The Garage door system needs maintenance	The garage door and motor need total maintenance

Maintenance

- Regular maintenance will extend the life of your garage door & motor and minimise potential faults/failures.
- Where lubrication is required, use a synthetic lubricant, chain oil or grease.
- **DO NOT use standard WD-40 or CRC as these will not provide correct lubrication and may attract dirt/dust**

ONGOING	
Door Operating Area	- Ensure there are no obstructions in the operation area of the garage door.
Motor & Rail	- Ensure the door is operating smoothly and quietly. If any noise or binding occurs, further maintenance or repairs may be required.
MONTHLY	
Safety Reverse Function	- Test the safety Reverse Function monthly. - Ensure the drive reverses when the door contacts a 40mm high object placed on the floor. - Adjust if necessary and recheck since an incorrect adjustment may present a hazard.
QUARTERLY	
Garage Door Rollers, Hinges & Rail	- Visually check the garage door hinges and rail for any signs of damage. - Lubricate the rail and rollers with an oil based spray lubricant, or grease. - Operate the manual release and check the operation is smooth and does not bind. - Test the Safety Reverse System operation to ensure it is detecting obstacles correctly.
ANNUALLY	
Garage Door, Rail and Motor	- Visually check all physical mountings and repair any loose or damaged fixings.

TECHNICAL SUPPORT

For installation or troubleshooting assistance visit richmondau.com/gate-motor-support/

Email: gatesupport@richmondau.com

AU: 03 9070 5713

NZ: 0800 61 71 81

International: +613 9551 2233

