

Swing Gate Opener User's Manual

For Model: GTR099

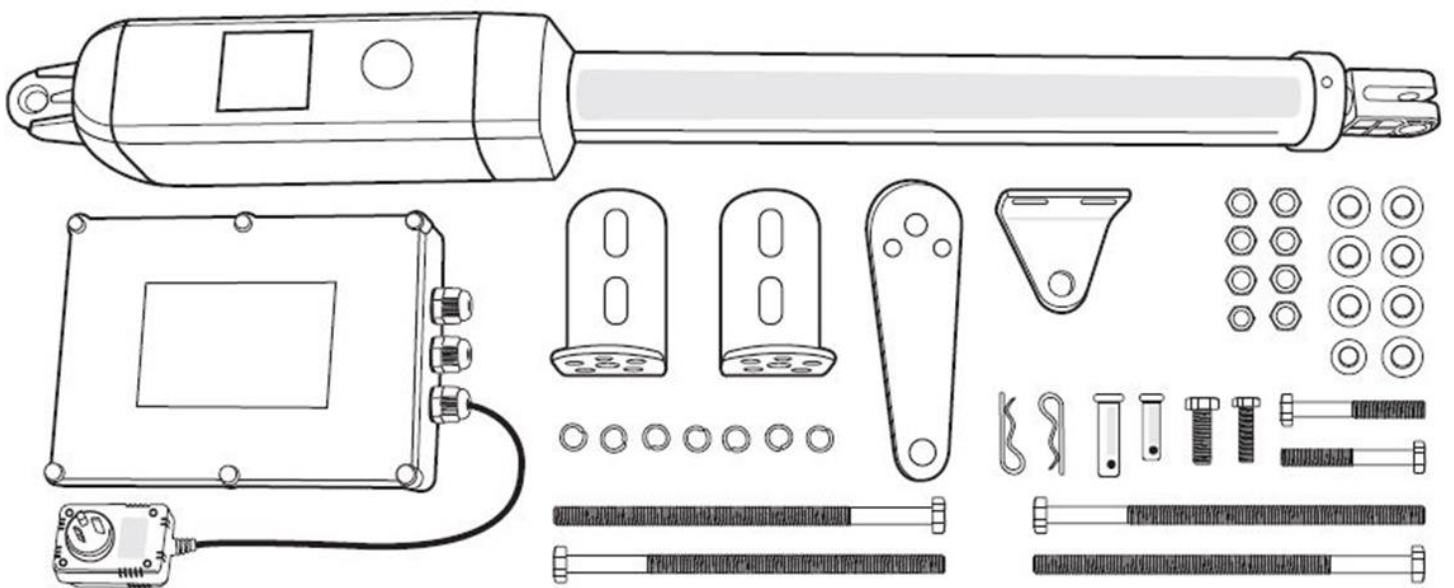

- Please read and follow all warnings, precautions and instructions before installation and use.
- 2 x 12V 7Ah batteries are supplied. The AC adaptor included, is used to maintain charge in the batteries.
- Periodic checks of the operator are required to ensure safe operation
- Save this manual for future reference

Safety Installation Information

1. READ and FOLLOW all instructions.
2. The gate opener is intended for use with Class I vehicular swing gates. Class I denotes a vehicular gate opener (or system) dwelling, or a garage or parking area associated therewith. Install the gate opener only when the opener is appropriate for the construction and the usage class of the gate.
3. Gate opening system designers, installers and users must consider the possible hazards associated with each individual application. Improperly designed, installed, or maintained systems can create risks for the user as well as the bystander. Gate system design and installation must reduce public exposure to potential hazards. All exposed pinch points must be eliminated or guarded.
4. A gate opener can create high levels of force during normal operation. Therefore, safety features must be incorporated into every installation. Specific safety features include safety sensors.
5. The gate must be properly installed and work freely in both directions prior to the installation of the gate opener.
6. The gate must be installed in a location so that enough clearance is provided between the gate and adjacent structure when opening and closing to reduce the risk of entrapment. Swinging gates shall not open into public access areas.
7. The opener is intended for use only on gates used for vehicles. Pedestrians must be supplied with a separate access opening. The pedestrian access opening shall be designed to promote pedestrian usage. The pedestrian access shall be located such that persons will not come in contact with the moving vehicular gate.



8. Pedestrians should never cross the pathway of a moving gate. The gate opener is not acceptable for use on any pedestrian gate. Pedestrians must be supplied with a separate pedestrian access.
9. For an installation utilizing non-contact sensors (safety sensors), see product manual on the placement of non-contact sensors (safety sensors) for each type of application.

- a. Care shall be exercised to reduce the risk of nuisance tripping, such as when a vehicle trips the safety sensor while the gate is still moving.
 - b. One or more non-contact sensors (safety sensors) shall be located where the risk of entrapment of obstruction exists, such as the perimeter reachable by a moving gate or barrier.
10. Never mount any device that operates the gate opener where the user can reach over, under, around or through the gate to operate the controls. Controls are to be placed at least 6' (1.8m) from any part of the moving gate.

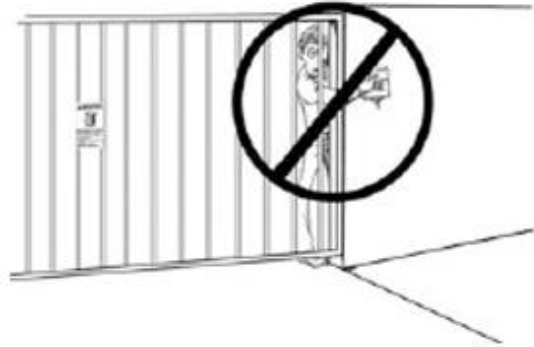

11. Controls intended to be used to reset an operator after 2 sequential activations of the entrapment protection device or devices must be located in the line of sight of the gate, or easily accessible controls shall have a security feature to prevent unauthorized use. Never allow anyone to hang on or ride the gate during the entire travel of the gate.
12. Each gate opener is provided with two safety warning placards. The placards are to be installed on the front and back of the gate where they are plainly visible. The placards may be mounted using cable ties through the four holes provided on each placard. All warning signs and placards must be installed where visible near the gate.

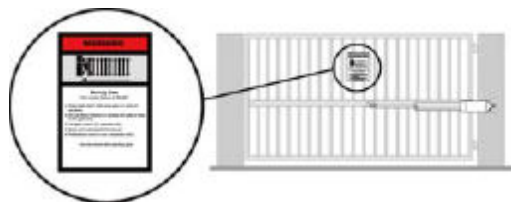

13. To AVOID damaging gas, power, or other underground utility lines, contact underground utility locating companies BEFORE digging.
SAVE INSTRUCTION
14. Do not permit children to play on or around the gate and keep all controls out of their reach.

Table of Contents

Safety Installation Information	2
Parts List	4
Technical Specifications & Tools Needed	5
Installation Overview	8
Preparation for Installation	9
Install the Gate Opener on the Gate	10
Mounting of the control box	16
Connection of the power supply	16
Connection of the control board	17
How to Program and Erase the Remote.....	18
Setting of the Control Board	19
Trouble Shooting	21
Battery charging instructions in the event of a flat battery.....	22

Parts List

				
		Gate Opener (1 pc)		
				
	CE Remote Control (2 pcs)			
Control Box (1 pc)			Warning Signs (2 pcs)	
		Release Key (1 pcs)		
				
DC Transformer (1 pc)	Battery Cable (1 pc)	Post Bracket (2 pcs)	Post Pivot Bracket (1 pc)	Gate Bracket (1 pc)
Hardware				
				
Φ10 Washer (7 pcs)		M10×200 Bolt (4 pcs)		
				
Φ10 Lock Washer (7 pcs)		M10×75 Bolt (2 pcs)		
				
Φ8 Washer (1 pc)		M10×30 Bolt (1 pc)		
				
M10 Nut (7 pcs)		M8×30 Bolt (1 pc)		
				
M8 Nut (1 pc)		12×40 Clevis Pin (1 pc)		
				
Hairpin Clip (2 pcs)		12×30 Clevis Pin (1 pcs)		

A large range of additional accessories are available.

For more information, please refer to www.richmondau.com or contact your closest Richmond store.

Technical Specifications & Features

Specifications – GTR099	
Fuse	F5L250V or F5AL250V
Voltage Input:	120V/60Hz or 230V/50Hz
Charging Adaptor Output:	36 volts DC @ 0.67 amps
Motor voltage:	24 volts DC
Actuator Power:	80 watts
Actuator Current:	3 amps
Actuator speed:	16mm/s
Max. actuator travel:	385mm
Ambient temperature:	-20°C~ +50°C (-4°F to 122°F)
Protection class:	IP44

Gate Capacity of GTR099

Gate Weight	380 kg	✓	NR	NR	NR	NR	NR	NR
	340 kg	✓	✓	NR	NR	NR	NR	NR
	300 kg	✓	✓	✓	NR	NR	NR	NR
	250 kg	✓	✓	✓	✓	NR	NR	NR
	200 kg	✓	✓	✓	✓	✓	NR	NR
	160 kg	✓	✓	✓	✓	✓	✓	NR
	110 kg	✓	✓	✓	✓	✓	✓	✓
		1.2-1.8 m	2.4 m	3 m	3.6 m	4.3 m	5 m	5.5 m
Gate Length								

Tools Needed

- Power Drill
- Tape Measure
- Open End Wrenches — 14mm & 17mm or Adjustable Wrenches
- Wire Strippers
- C-Clamps — small, medium, and large
- Level
- Hacksaw or Heavy Duty Bolt Cutters
- Phillips Screwdriver
- An extra person will be helpful

Converting to Low Voltage or Solar Power

Your GTR099 gate opener can be converted to either Low Voltage Power Supply, or Solar Power. For more information, please refer to the GTR099 product page at www.richmondau.com.

You can also contact our technical support team at www.gatesupport.richmondau.com and they can provide further information on how to safely convert your GTR099 power source.

Dimensions

Retracted Gate Arm Dimensions:

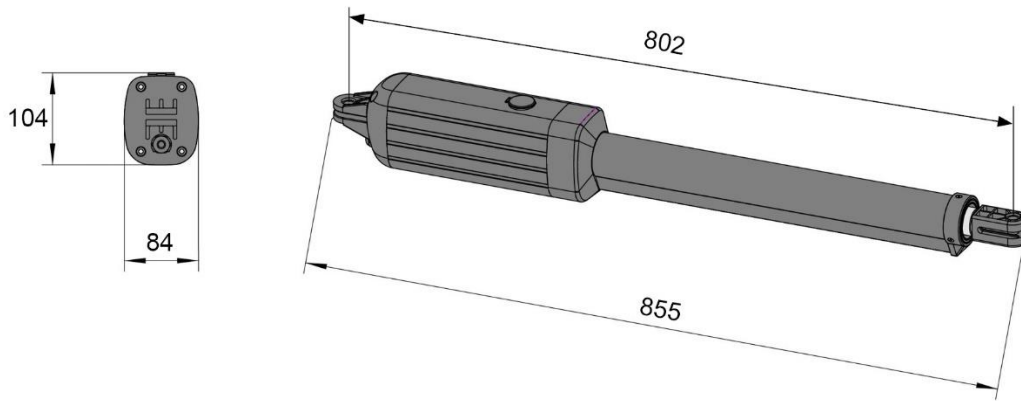

Extended Gate Arm Dimensions:

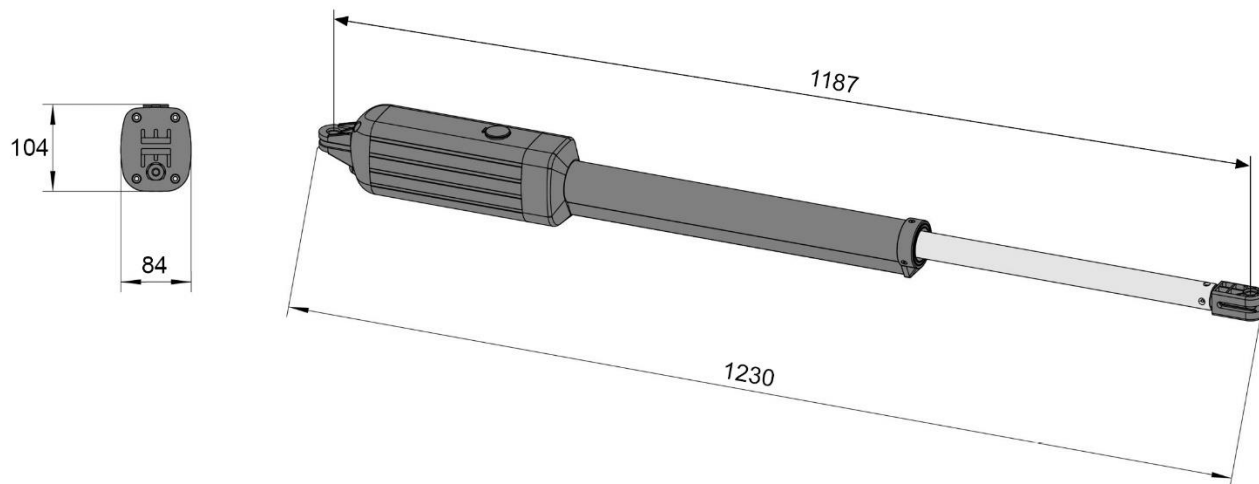

Dimensions

Gate Bracket Dimensions:

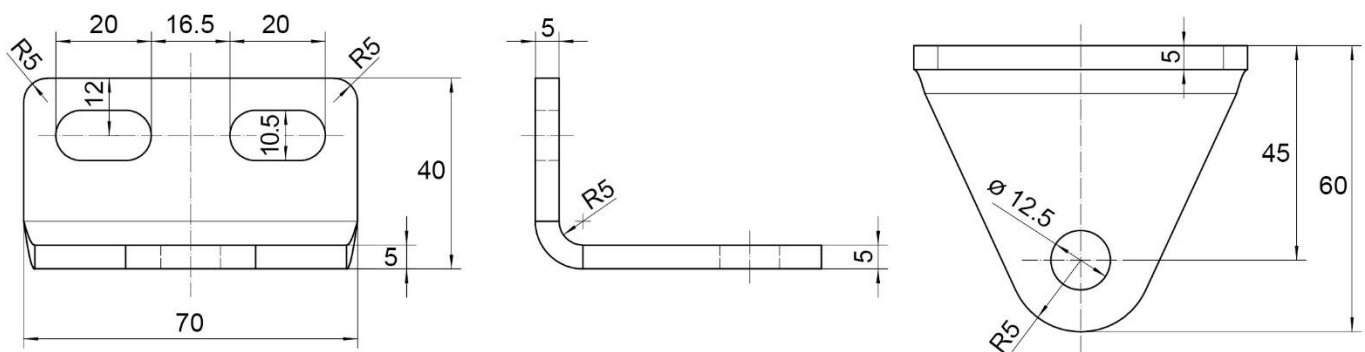

Post Bracket Dimensions:

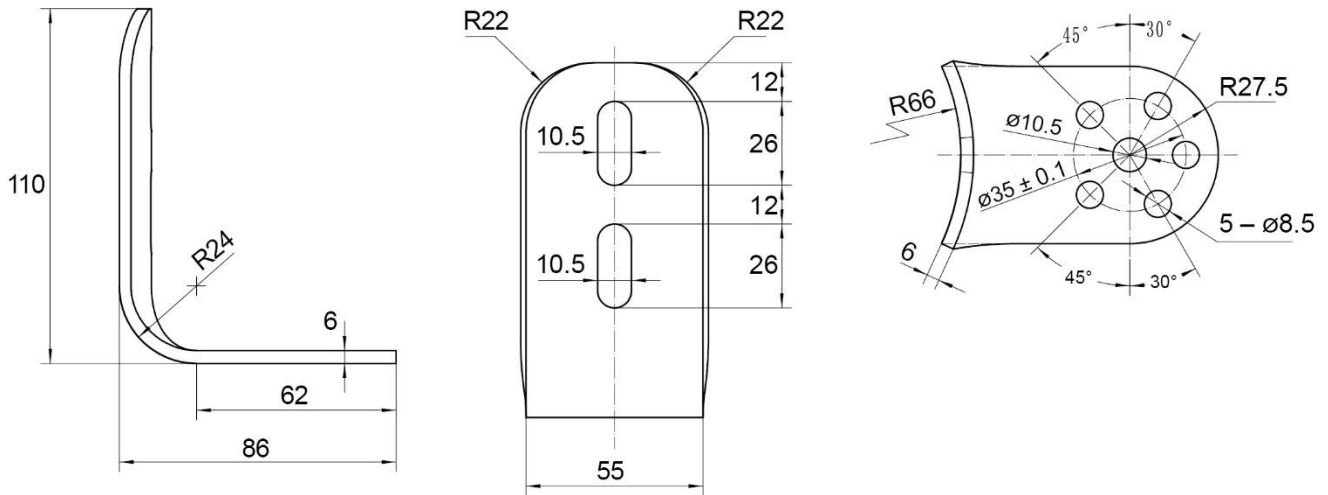

Post Pivot Bracket Dimensions:

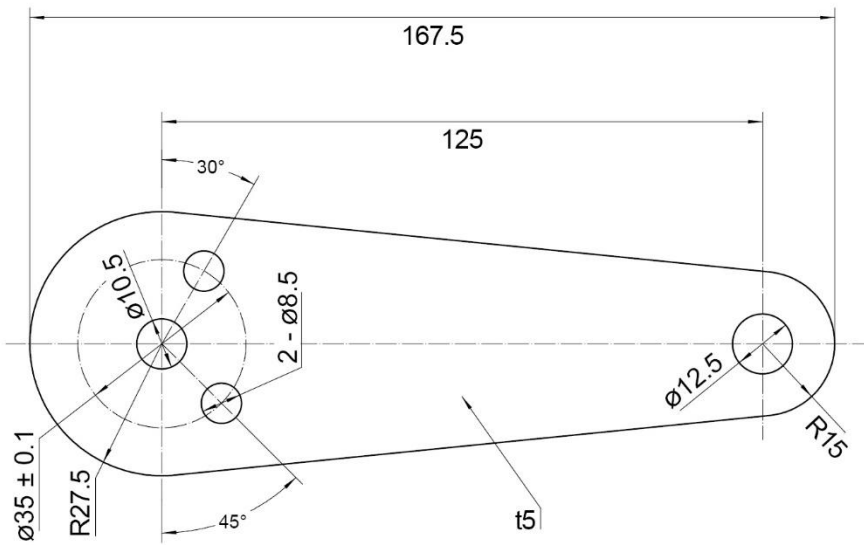

Installation Overview

Single Gate Overview

Pull-to-Open Gate

⚠ WARNING To prevent SERIOUS INJURY or DEATH , at least one non-contact sensor should be located where the risk of entrapment or obstruction exists.
--

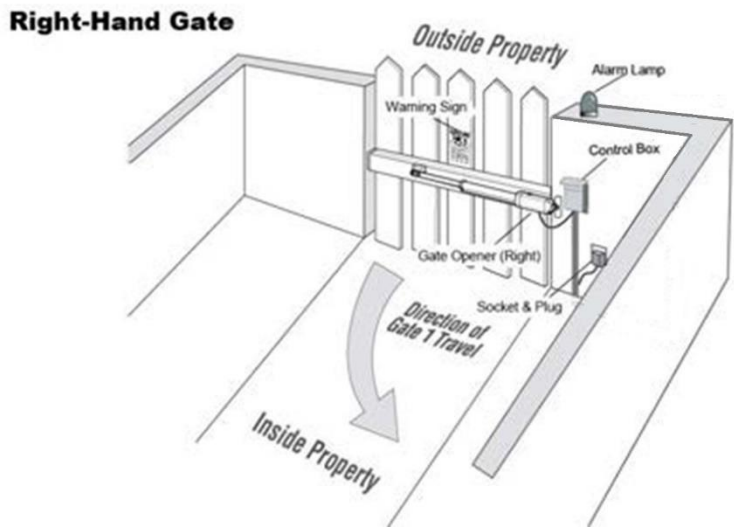
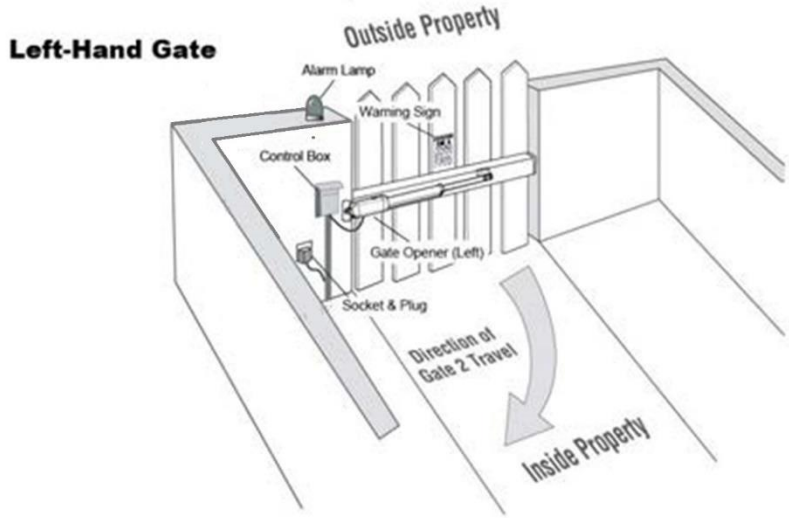

Note: for best performance we always recommend attaching the arm to the centre of the gate.

Preparation for Installation

There are two installation types for the gate opener, Pull-to-Open and Push-to-Open. In the Push-to-Open installation, gate opens out from the property. A Push-To-Open Bracket (GTR059) is required to be used for each gate.

NOTE: Ensure the gate does not open into public areas.

The gate opener is mounted to the gate and to the gate post. Both round and square posts can be used because the Post Brackets are curved. When mounting the Post Brackets, use bolts long enough to pass through the entire post. M10 x 200 bolts are included. Concrete anchors are not provided.

When mounting the Post Brackets to wooden posts, a larger-size washer or metal plate should be used between the bolts and the wooden post to ensure the stability of the fastening hardware. If the post is smaller than 6" diameter or square, it should be made of metal and set in cement to ensure its stability.

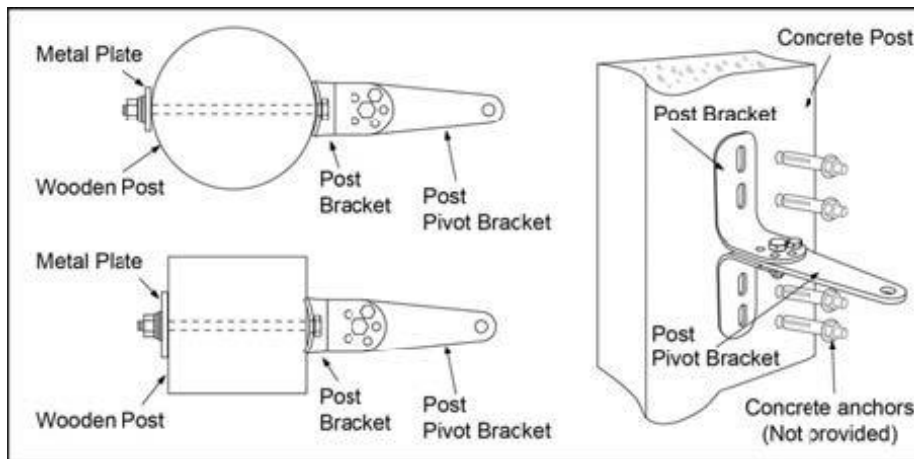

Install the Gate Opener on the Gate

The position of Post Bracket is very important. The following illustrations and tables are required to determine the proper mounting position for the Post Bracket. The tables show the maximum opening angle of the gate for a given A and B. For example, if A is 15cm and B is 20cm, the maximum opening angle of the gate is 110°. Pull-to-Open Installation — Gate in Closed position (Moving-Rod is extended).

Note: for best performance we always recommended attaching the arm in the centre of the gate.

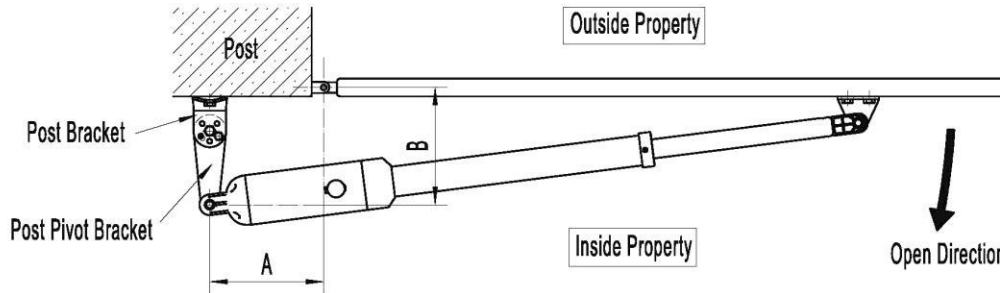

	A=8cm	A=9cm	A=10cm	A=11cm	A=12cm	A=13cm	A=14cm	A=15cm	A=16cm	A=17cm	A=18cm	A=19cm	A=20cm	A=21cm	A=22cm
B=19cm	90°	93°	96°	98°	101°	104°	106°	108°	110°	105°	102°	98°	95°	93°	91°
B=20cm	91°	93°	95°	98°	100°	103°	107°	110°	104°	99°	96°	94°	92°	90°	89°
B=21cm	91°	93°	95°	97°	100°	103°	106°	103°	99°	96°	93°	91°	89°	88°	
B=22cm	91°	94°	95°	97°	99°	101°	103°	98°	95°	92°	90°	89°	87°		
B=23cm	92°	94°	96°	98°	100°	103°	98°	94°	92°	90°	88°	86°			
B=24cm	90°	92°	95°	97°	99°	97°	93°	91°	88°	87°	85°				
B=25cm	90°	92°	94°	97°	96°	92°	90°	87°	85°	84°					
B=26cm	90°	92°	94°	95°	91°	88°	86°	84°							
B=27cm	90°	92°	95°	90°	87°	85°									
B=28cm	90°	93°	89°	86°	84°										

Please Note: Each swing arm contains an internal thread that may separate if over extended. If overextended “Click” may be heard, to re-connect push and screw the sliding arm Clockwise until the arm begins to retract by hand.

Push-to-Open Installation — Gate in Closed position (Moving-Rod is retracted)

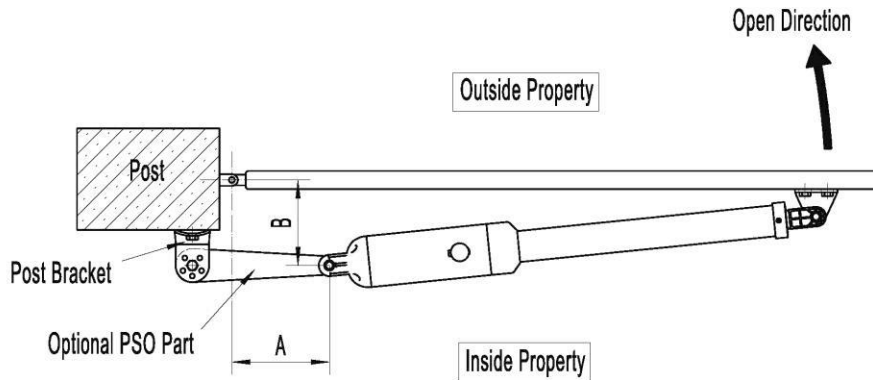

	A=10cm	A=12cm	A=14cm	A=16cm	A=18cm	A=20cm	A=22cm	A=24cm	A=26cm
B=9cm	90°	100°	111°	120°	125°	117°	108°	99°	90°
B=11cm	90°	98°	107°	115°	120°	111°	100°	92°	86°
B=13cm	90°	97°	104°	110°	114°	104°	94°	87°	
B=15cm	90°	98°	105°	112°	109°	97°	89°		
B=17cm	90°	96°	101°	108°	101°	91°	83°		
B=19cm	90°	95°	100°	106°	93°	85°			
B=21cm	90°	94°	99°	97°	87°				
B=23cm	90°	93°	97°	90°	81°				
B=25cm	90°	93°	94°	83°					
B=27cm	90°	92°	86°						

1. Insert the M10 x 30 bolt through the centre hole of the post bracket and post pivot bracket as shown. Place a Φ 10 washer, Φ 10 lock washer and M10 nut on the bottom of the bolt and hand tighten.

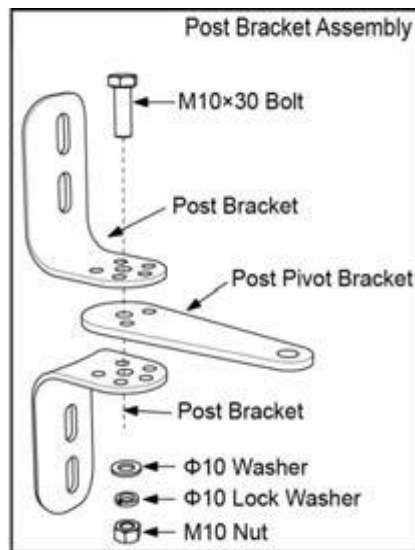

2. Attach the gate bracket and post bracket assembly to the opener by inserting a clevis pin. Secure the clevis pins using the hairpin clips.

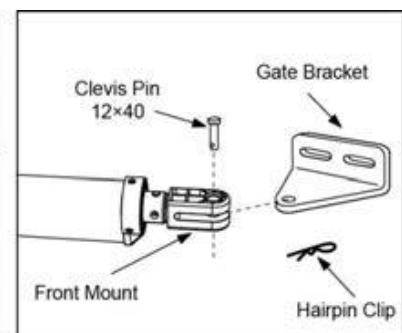
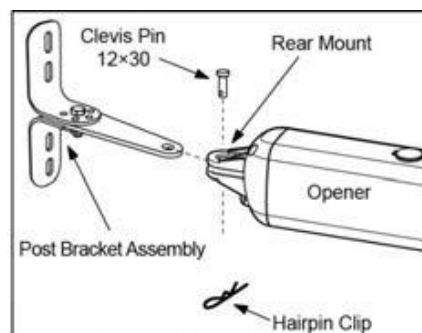

3. Open the release hole plug on the top of the gate opener, insert the release key, and turn the key 90° clockwise. This releases the motor and allows the push-pull rod to be manually extended and retracted. To restore normal operation, turn the key 90° counter-clockwise.

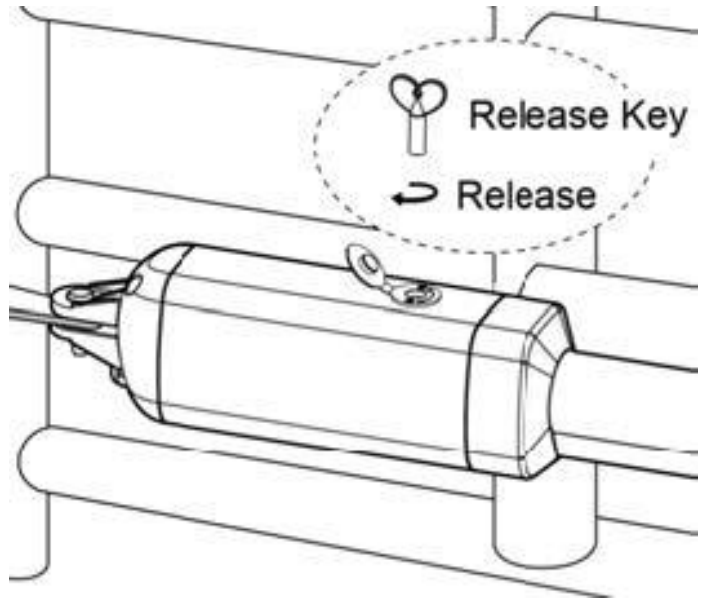

4. With the opener fully retracted and with the gate in the fully open position (for Pull-to-Open installation) or fully closed position (for Push-to-Open installation), place the gate opener with the Post Bracket Assembly and Gate Bracket on the gate post and the gate. Position the Post Bracket Assembly and Gate Bracket so that the gate opener is level. While holding the gate opener in the level position, temporarily secure it with two C-clamps.

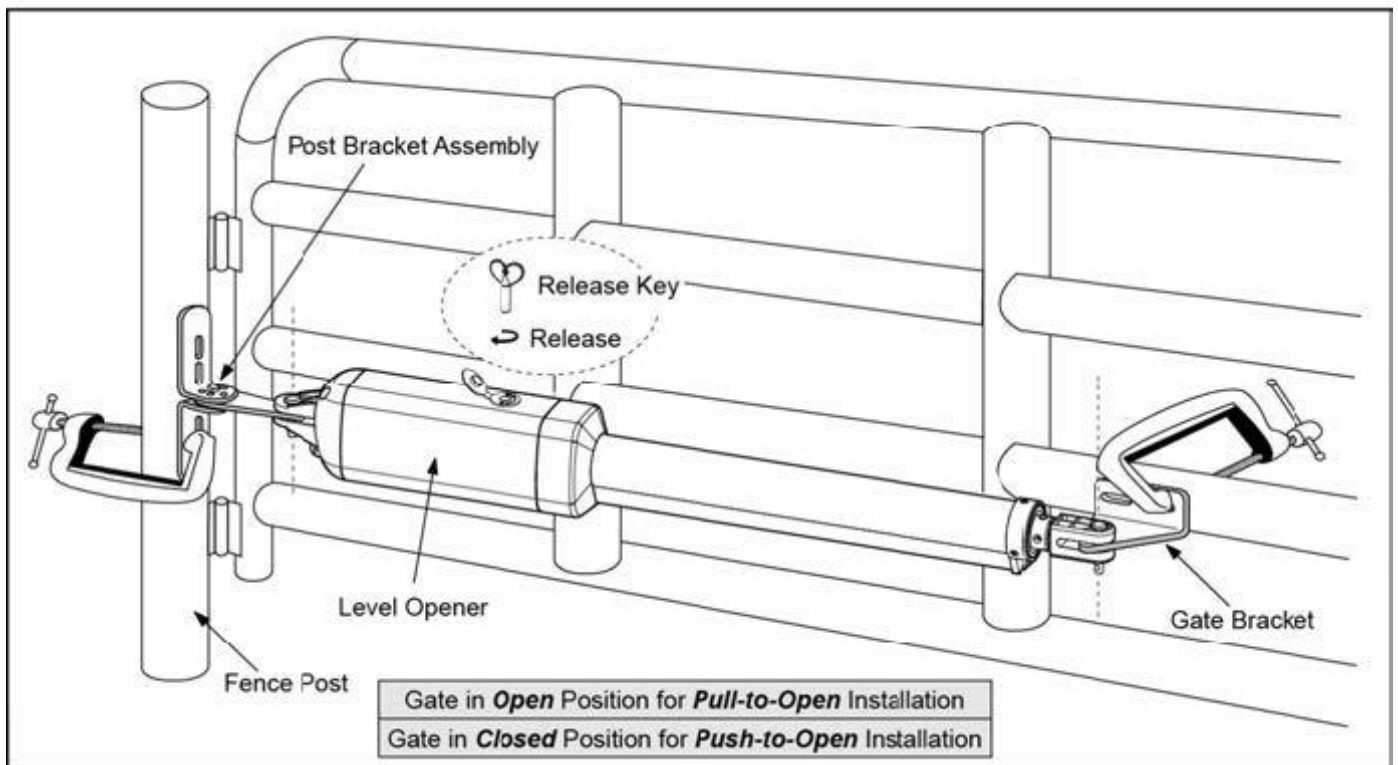

5. Make sure that there is a minimum clearance of 2.5cm between the gate and the opener and that the opener and the Post Pivot Bracket are not binding in both the gate-open and gate-closed positions. If there is not at least 2.5cm of clearance or if the opener and the Post Pivot Bracket are binding, rotate the Post Pivot Bracket and/or move the Post Bracket Assembly to obtain the minimum clearance and eliminate the binding. When the minimum clearance has been obtained and any binding has been eliminated, place the M8 x 30 bolt through the aligned holes in the Post Bracket and the Post Pivot Bracket.

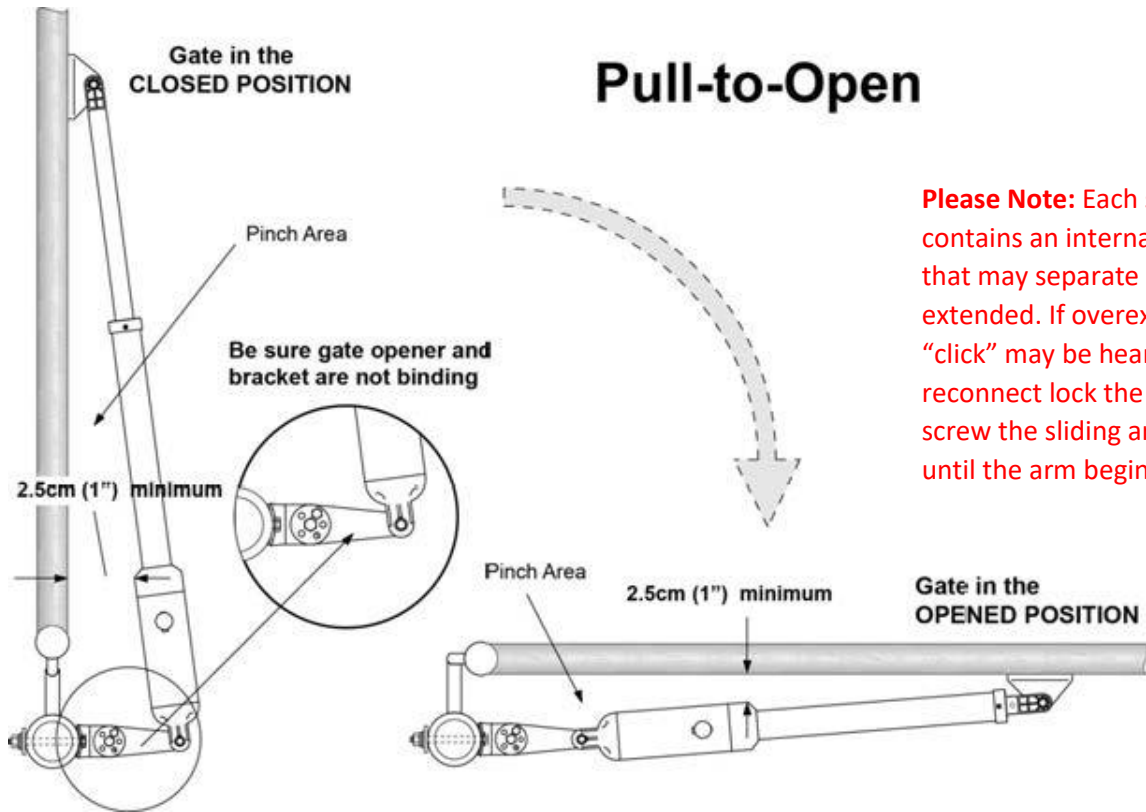

Please Note: Each swing arm contains an internal thread that may separate if ever extended. If overextended a “click” may be heard. To reconnect lock the arm and screw the sliding arm clockwise until the arm begins to retract

Push-to-Open



GTR059 bracket required for push to open installation (sold separately)

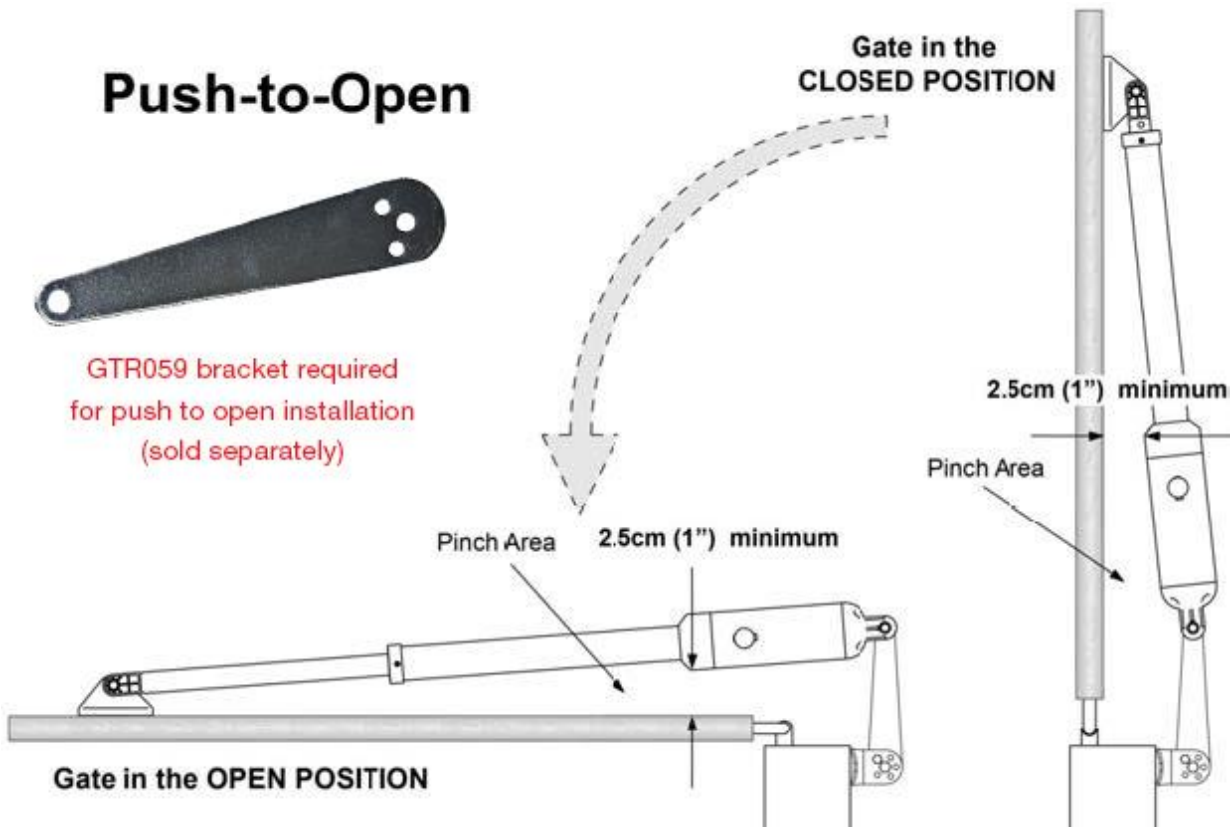

6. Sign the bolt-hole point on the gate bracket and gate. Do this by placing a punch or a sign in the middle of each bolt slot on the post bracket assemblies and the gate bracket. It allows slight adjustments to the post bracket. Then remove the post bracket and gate bracket by taking off the C-clamps.

7. Drill 10.5 mm diameter holes through the post and the gate at the marked locations.

8. Attach the post bracket assemblies to the gate posts by inserting M10 x 200 bolts through each post bracket assembly and the drilled holes in the gate post. Fasten each bolt with one Φ 10 washer, one Φ 10 lock washer, and one Φ 10 nut.

9. Attach the gate brackets to each gate by inserting two M10 x 75 bolts through the gate brackets and the drilled holes in the gates.

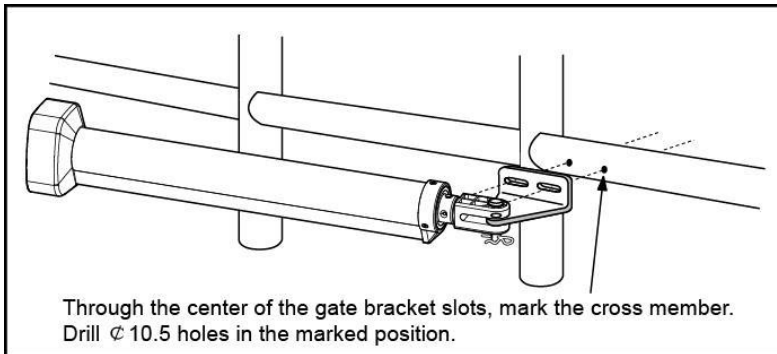
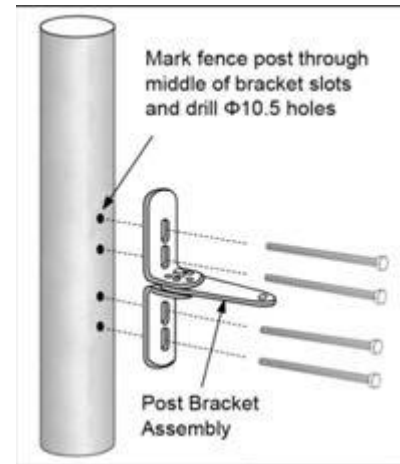

10. Cut off any part of the bolts that extend beyond the tightened nuts.

11. With the gate opener fully retracted and with the gate in the fully open position (for Pull-to-Open installation) or fully closed position (for Push-to-Open installation), attach the gate opener to the Post Bracket Assembly and the Gate Bracket by inserting a clevis pin through the gate opener and the Post Pivot Bracket and another clevis pin through the gate opener and the Gate Bracket. Secure each clevis pin with a hairpin clip.

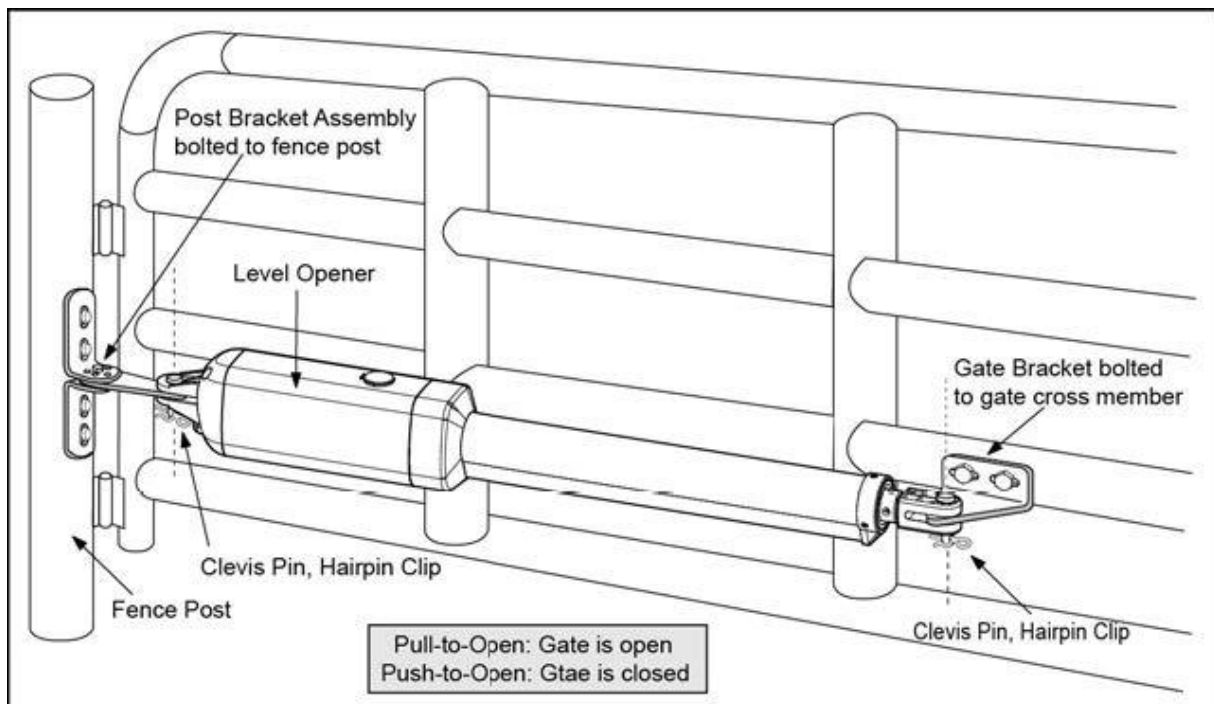

12. Open the release hole plug on the top of the gate opener, insert the release key, and turn the key 90°counterclockwise. This restores normal operation.

Adjusting the Travel Limit Switch:

The limit switch controls the closed position (stop point) of the gate. Moving the limit switch closer to the hinge point of the gate (the gate post) will make the gate stop at an earlier point when closing. Moving the limit switch away from the hinge point will make the gate stop at a later point when closing.

To adjust the limit switch, use a screwdriver to loosen the screw of Limit Switch A, slide to the correct position, and then tighten the screw again.

Pull to Open Limit Switch Adjustment:

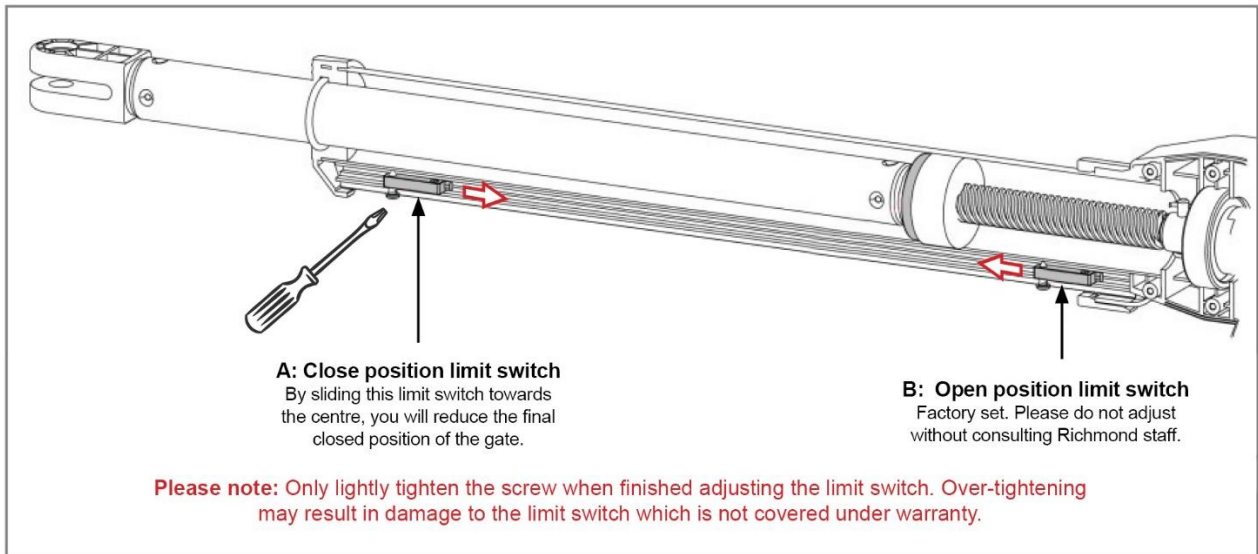

Please Note: The swing arm contains an internal thread that may separate if over extended. If overextended “Click” may be heard, to re-connect push and screw the sliding arm Clockwise until the arm begins to retract by hand.

Push to Open Limit Switch Settings:

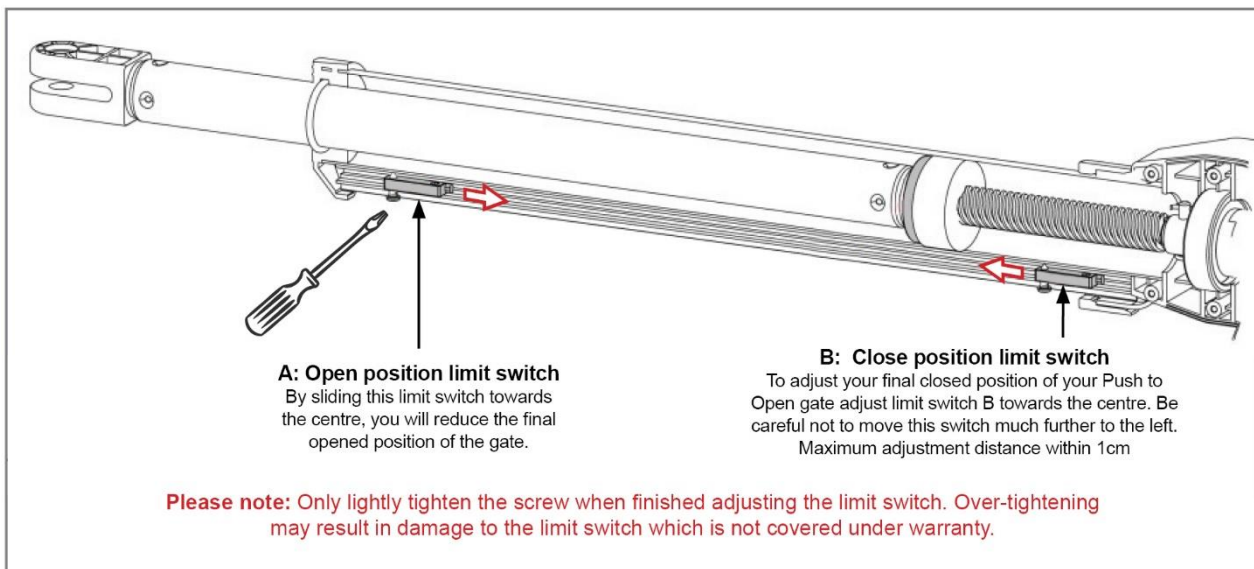

Mounting the Control Box:

Important: Ensure the control box is installed in a secure surface and at least 100 cm (40 inches) above the ground to protect it from rain, frost, etc. which may cause damage to the control box.

Remove the cover of the control box and use 4 deck screws (not provided) to install the control box.

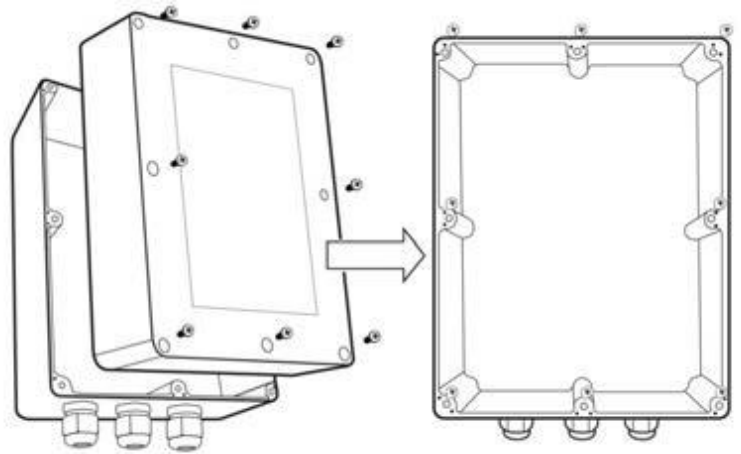

Connecting the Power Supply:

▲ **The gate opener is powered by 24VDC. 2 x 12v 7Ah batteries are supplied with the gate opener. For larger or more frequently opened gates, larger batteries may be required. The following diagram will show you how to connect 2 PCS batteries in series.**

Use of the correct charging adaptor is important. An incorrect charger can result in damage, or insufficient charge. Please note the wire connection. Incorrect wire connection may damage the control board.

- ▲ **The battery used should be waterproof or you should place them in a waterproof case.**
- ▲ **Please ensure other wire connections are completed before connecting the power supply.**

Please refer to the illustration “wire connection of the control board” to connect the battery and DC transformer to the control board.

The “24V+” of the battery should be wired to the **BAT+ (#11)** terminal,

The “24V-” should be wired to “**BAT- (#12)** terminal. **The wire (2*0.75mm², 2 meters long) for connecting the battery has been provided and connected to the control board in factory.**

The DC transformer is supplied wired to the “**DC24V (#13, #14)** terminals of the control board.

The length of the wire of the transformer is 1.5m(5'). So if the distance between the outlet and the control box is longer than that, you should use an extended wire to connect the transformer to the control board. The wire size should be at least 16AWG.

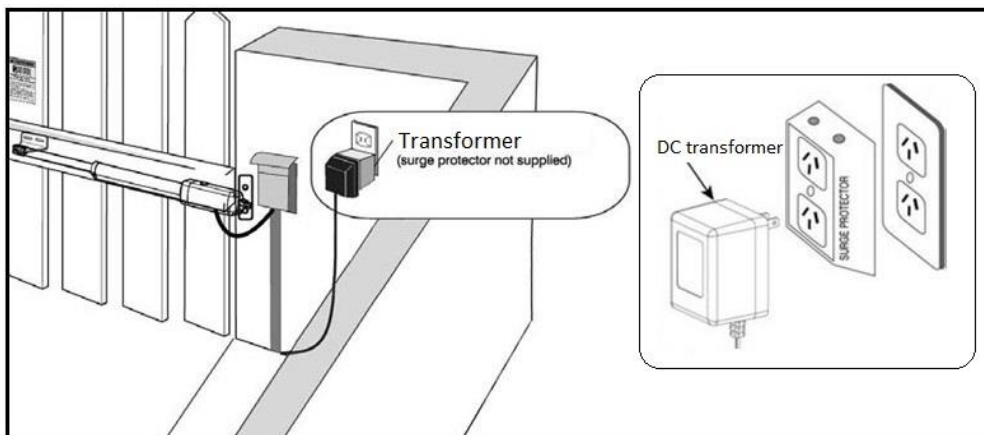

Plug the transformer into the electrical outlet once the battery connections are completed. Use of a surge protector with the transformer is recommended. If electrical outlet is located outdoors, outlet and transformer must be protected by a weatherproof cover. All work with mains power must be done by a qualified electrician.

Connection of the Control Board:

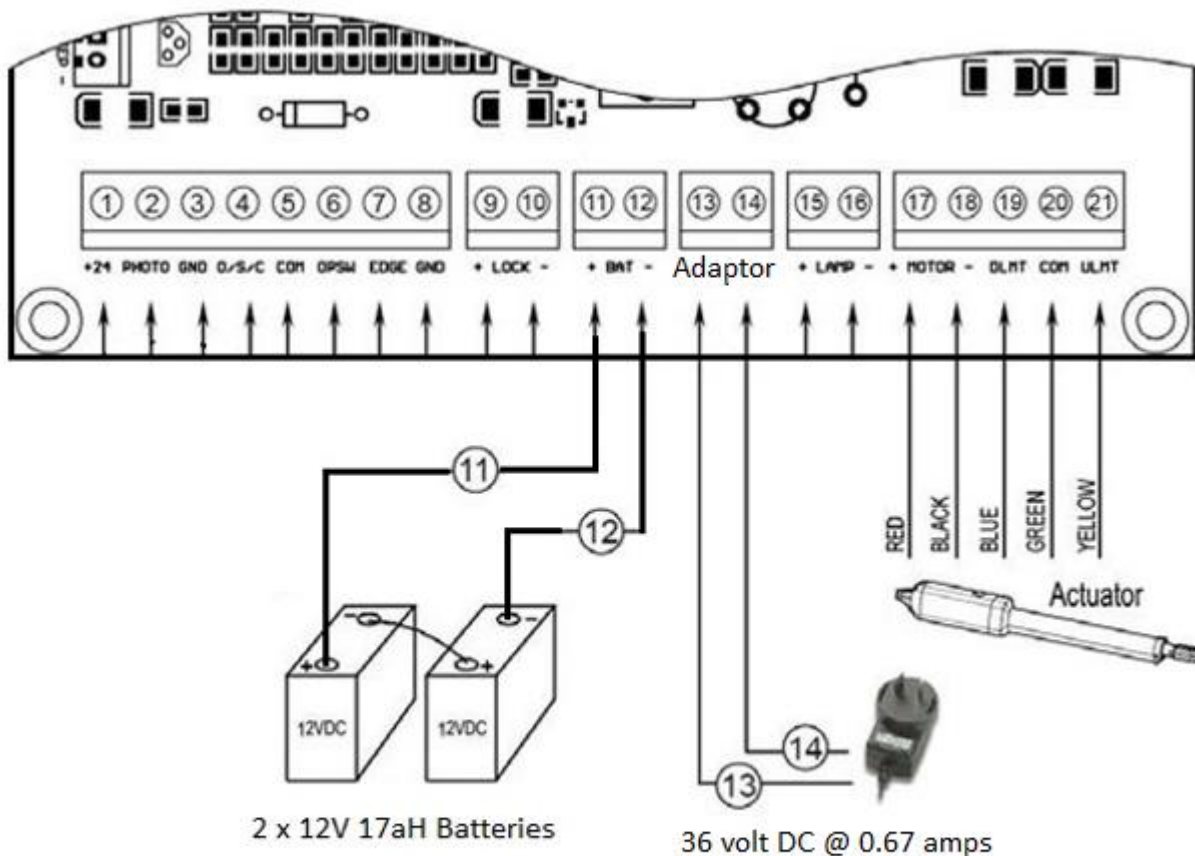

For additional accessory fitting, please refer to your accessory manual.

Connecting wires using screw-type terminals:

To connect to any of the screw type terminals on the circuit board, you will need to firmly pull the green terminal off the circuit board and use a small screwdriver to loosen the screw. Make sure the wire is cleanly twisted or soldered, and there are no frayed wires sticking out. Feed the wire into the required terminal, ensuring full contact with the metal. Retighten the screws, and then tug on the wire to ensure that it is securely fastened. Once all wires are inserted and fastened, push the green terminal back into the circuit board, making sure it clicks in and is sitting flush. Lastly, check that the wires are not contacting a neighbouring terminal as this can cause a short circuit.

1. Actuator

The red wire should be inserted into the "+MOTOR" terminal (#17), the black wire into "MOTOR-" terminal (#18), the blue wire into "DLMT" terminal (#19), the green wire into "COM" terminal (#20), and the yellow wire into "ULMT" terminal (#21).

2. Battery

Connect the "24V+" of the battery to the +BAT (#11) terminal, Connect the "24V-" to "BAT-" (#12) terminal.

3. DC Power Adaptor

Insert the stripped cable wires into DC24V (#13) terminals to the control board.

How to Program the Remote to the Opener:

You must program the remote to the opener before operating. You can follow the below steps to program the remote to the opener.

Press and release the CODE SW button, the CODE LED will be ON, then press the key in the remote twice in 4 seconds, the CODE LED will flash for 3 seconds and then to OFF. Now the remote has been programmed successfully.

NOTE: The button of the remote control should be pressed and hold for more than 2 seconds while programming. Max. 10 remotes can be programmed for the opener. If you want program more remotes, you should use an optional external receiver.

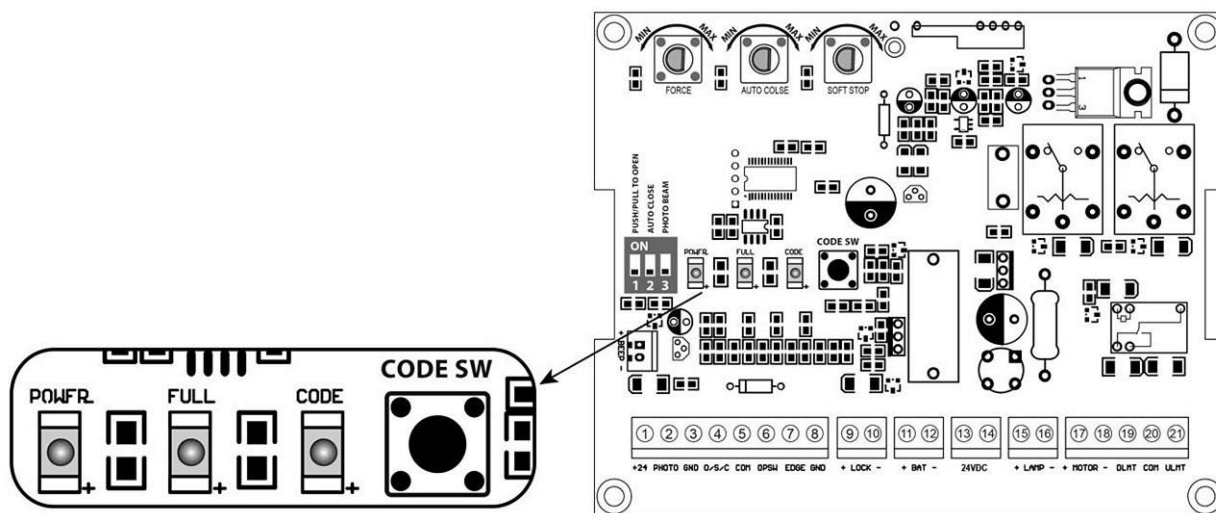

How to use the Remote to Operate your Gate Opener:

Each remote has four buttons, from top to bottom are separately A, B, C and D. You may use this remote to operate as many as 4 sets our swing gate opener or 1 set our sliding gate opener and 2 sets our swing gate opener.

1. Use this remote to only operate our swing gate opener A, B, C and D four buttons share same function once they are programmed with our swing gate opener. You may choose any button to program it with our swing gate opener. Every press of the button is able to activate the gate opener to work alternately (open-stop-close-stop-open).

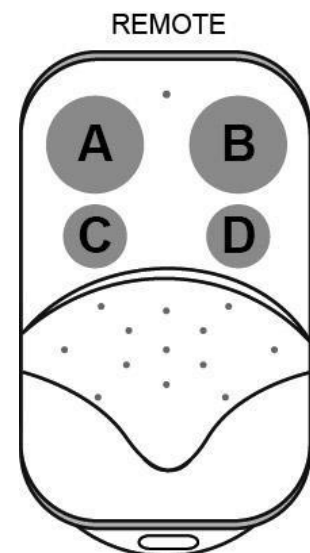

How to Erase All Remote Controls:

Press and hold the CODE SW button until the CODE LED goes from ON to OFF.

This will take approximately 8 seconds and will remove all remote memory from the gate motor.

You can now re-learn any remotes or wirelessly connected accessories.

Setting of the Control Board:

▲ WARNING: Ensure the gate opener is Power Off when you make any adjustment of the gate opener. Keep away from the gate once power has been restored in case of the unexpected gate movement. Carefully adjust the DIP switches to avoid the risk of machine damage and injury or death. Always ask the help of professional technician /electrician if you have any question.

1. DIP Switches

The DIP switches are used to select pull/push to open, enable/disable auto close function, enable/disable photobeam function.

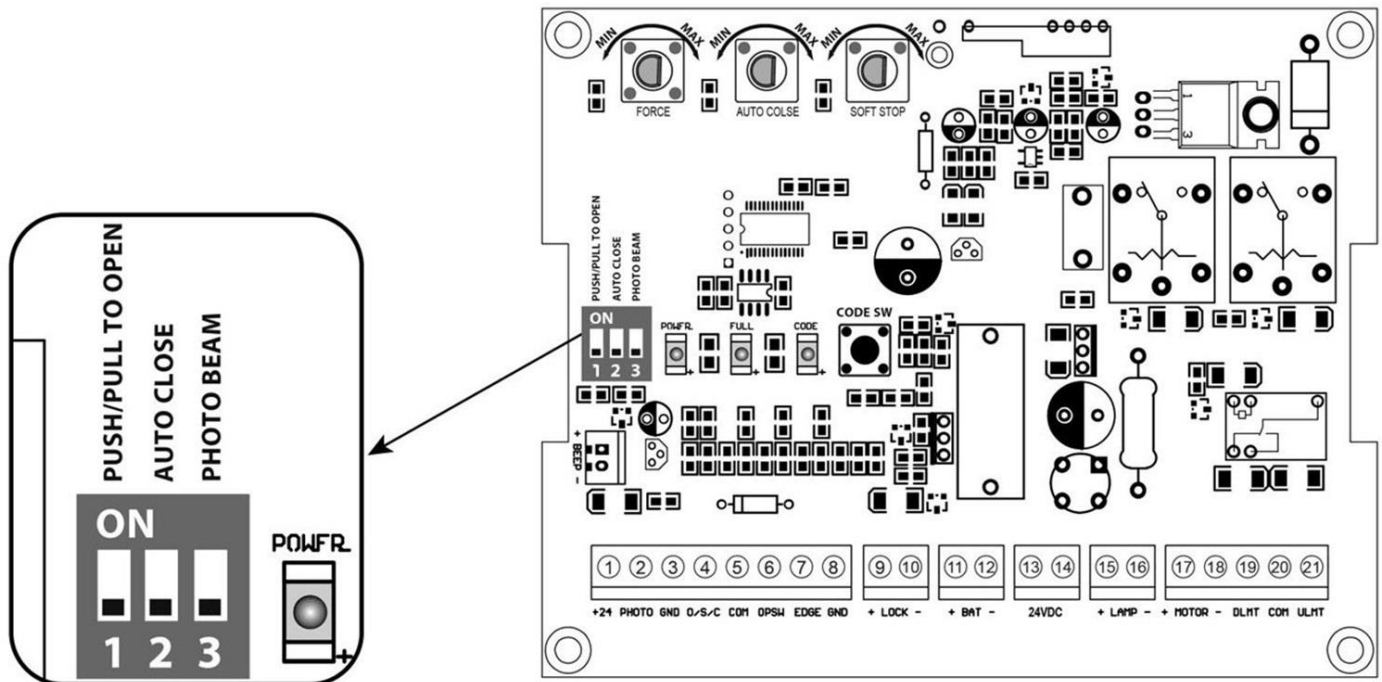

DIP Switch #1: Select push/pull to open

If the gate opens **INTO** the property (pull to open), the DIP Switch is set to OFF (factory default setting).

If your gate opens out from the property (push to open) the DIP Switch must be set to the ON position.

Factory default setting is OFF. (Pull to Open)

DIP Switch #2: Auto close function enabled/disabled

ON – Auto close function enabled.

OFF – Auto close function disabled.

Set the switch #2 to ON to enable the auto close function.

Factory default setting is OFF.

DIP Switch #3: Photocell function enabled/disabled

ON – Photocell function enabled.

OFF – Photocell function disabled.

You must set the switch #3 to ON to enable the photocell function if you want to use the photocell with the gate opener.

Factory default setting is OFF.

2. Potentiometers

There are 3 potentiometers located in the control board. They are used to adjust the stall force, auto-close time and soft stop period.

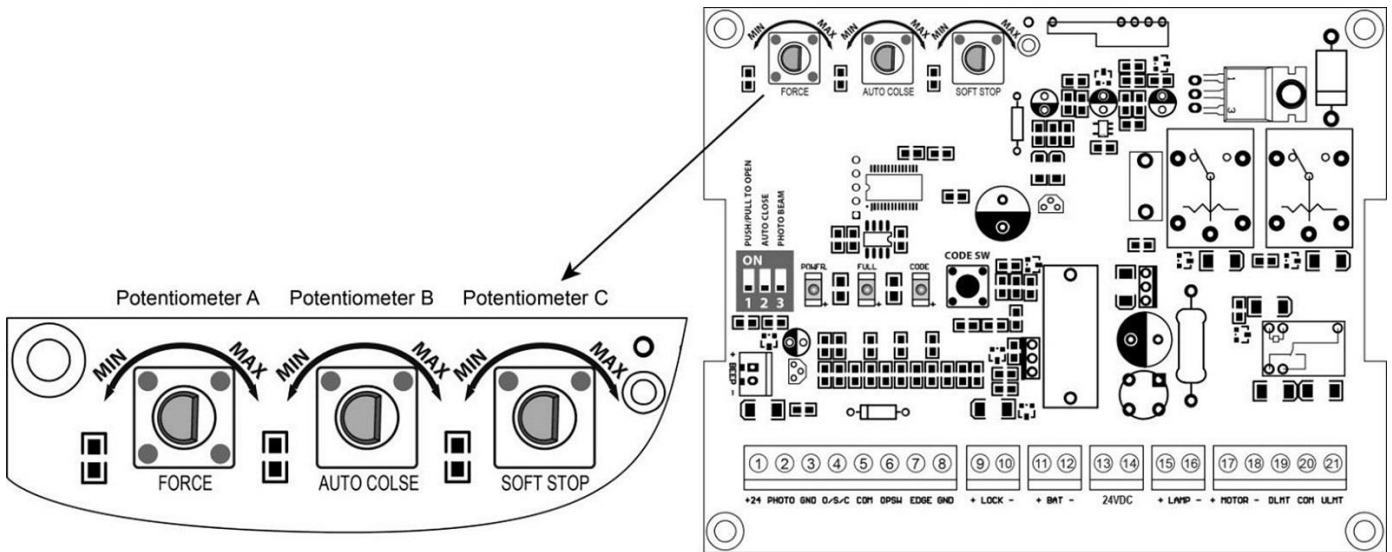

Potentiometer A

Used to adjust the stall force the gate opener. Turn the potentiometer clockwise to increase the stall force and turn it counter-clockwise to decrease the stall force.

Potentiometer B

Used to adjust the auto close time of the gate opener. Turn the potentiometer clockwise to increase the auto close time and turn it counter-clockwise to decrease the auto close time. The auto close time can be adjusted stepless from 3 to 120 seconds.

Potentiometer C

Used to adjust the soft stop period of the gate opener. Turn the potentiometer clockwise to increase the soft stop period. Turn it counter-clockwise to decrease the soft stop period. The auto close time can be adjusted stepless from 1 to 5 seconds.

Troubleshooting:

Have a multi-meter to check voltage and continuity. Use caution when checking high voltage terminals.

Symptom	Possible Solution(s)
The opener does not run. Power LED flash very quickly.	1. Battery is over-discharged. Check the voltage of the battery. The voltage of the battery should above 22V to make the gate opener work normally.
The opener does not run. Power LED does not turn ON.	1. Make sure the connection between the battery and control board is correct and fastening. 2. Check the fuse in the control board. Replace the fuse if it was burnt out. 3. Check the control board. Replace the control board if necessary.
Gate moves a little and then reverse or stop	1. The selected force is too small to move the gate. Turn the Potentiometer clockwise to increase the force. 2. Disconnect the gate from the gate operator and check that the gate slides freely without any binding.
Gate opener does not run when you press the remote control	1. Make sure the connection of the photocell beam is not blocked if the photocell is used. 2. Check if the close limit switch is broken. 3. Check the control board. Replace the control board if necessary.
Gate can open but does not close	1. Setting of DIP switch #1 could be wrong. Please set the dip switch correctly according to the push/pull to opener installation of the gate opener.
Gate automatically opens, but does not automatically close	1. Setting of DIP switch #1 could be wrong. Please set the dip switch correctly according to the push/pull to opener installation of the gate opener.
Gate arm is over-extended and won't retract	1. Each swing arm contains an internal thread that may separate if over extended. If overextended "Click" may be heard, to re-connect push and screw the sliding arm Clockwise until the arm begins to retract by hand

For any technical enquiries, please call Richmond Wheel & Castor Co on 1300 474 246 or fill out the support form located at gatesupport.richmondau.com

Suggested maintenance for your swing gate & motor.

- Regular maintenance will extend the life of your gate and motor and minimise potential faults/failures.
- Where lubrication is required, use a synthetic lubricant, chain oil or grease.
- **DO NOT use standard WD-40 or CRC as these will not provide correct lubrication and may attract dirt/dust.**

ONGOING	
Driveway	- Ensure that the area where the gate travels remain free of any obstructions.
Swing Arms	- Ensure the manual release is covered when not in use.
QUARTERLY	
Mounting Brackets	<ul style="list-style-type: none"> - Visually check the mounting brackets for any signs of movement. Tighten bolts if necessary. - Inspect the arm hinge pins and lubricate with a synthetic spray lubricant.
Swing Arms	<ul style="list-style-type: none"> - Operate the manual release. Lubricate the manual release mechanism with a synthetic spray lubricant. - With the piston fully extended, clean any debris, or build up from the piston surface. Lubricate the piston with a synthetic spray lubricant. - Check underneath the arm to ensure vent holes in the main housing are not blocked.
Gate Hinges	- Inspect and lubricate the gate hinges with a synthetic spray lubricant. Use heavier grease if bearing hinges are being used.
ANNUALLY	
Control Box	<ul style="list-style-type: none"> - Turn off the power. Remove the outer cover and inspect the control box for any signs of moisture, bugs, dirt etc. - Visually inspect the PC board and wiring for any signs of corrosion/damage. - Inspect the seal on the cover for any damage or twisting. Ensure this in place before replacing the cover on the control box. - With the cover back on, apply a bug barrier spray around the perimeter of the control box.
Driveway	- If ground stoppers are being used, check the mounting bolts and tighten if necessary.
SPECIAL MAINTENANCE	
Mounting Brackets	- After storms/heavy winds or a suspected gate impact, check the mounting brackets are not damaged and have not moved.
Locations with extreme weather	<ul style="list-style-type: none"> - Corrosion protection: Coastal/humid locations. - The PC boards can be coated with a protective coating. Remove the PC board and coat with a circuit board lacquer for extra protection.
Additional maintenance	- Contact gatesupport@richmondau.com if you have an ongoing or recurring issue.

Battery Charging:

Important: Care is essential when handling your battery for charging. With incorrect handling and overcharging, shorting can occur.

Important: Protective glasses and gloves should be worn when charging a battery. To prevent shorting and damage to your battery, it is essential to avoid connection of the terminals with metallic or conductive materials. Prior to charging your battery, all electrical components must be switched off before connecting a charger. If the battery needs to be removed from its case for charging, care must be taken in the removal of the battery.

Important: The charger must be connected to the battery before the charger is connected to mains power.

How to connect a single battery for charge?

Richmond recommends connecting one 12v battery to one 12v charger to recharge your battery. When recharging your battery always remember to connect the positive charger (red) output to the positive (+) battery terminal. The negative charger output (black) connects to the negative (-) battery terminal. Once the battery is fully charged disconnect the charger from mains power first. Then disconnect the cables from the battery. Always ensure the charger and the battery have the same voltage when recharging the battery.

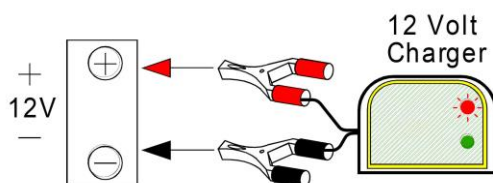

How to connect two batteries in a series for charge with one 24v battery charger?

To charge two 12v batteries in a series at the same time, connect a single 24v charger. This can only be done when the batteries in a series requiring charge have the same voltage output as the battery charger. As illustrated below. When recharging your batteries always remember to connect the positive charger (red) output to the positive (+) battery terminal. The negative charger output (black) connects to the negative (-) battery terminal. Once the batteries are fully charged disconnect the charger from mains power first. Then disconnect the cables from the battery. Always ensure the charger and the battery have the same voltage when recharging the battery.

