

Swing Gate Opener User's Manual

For Model: GTR099

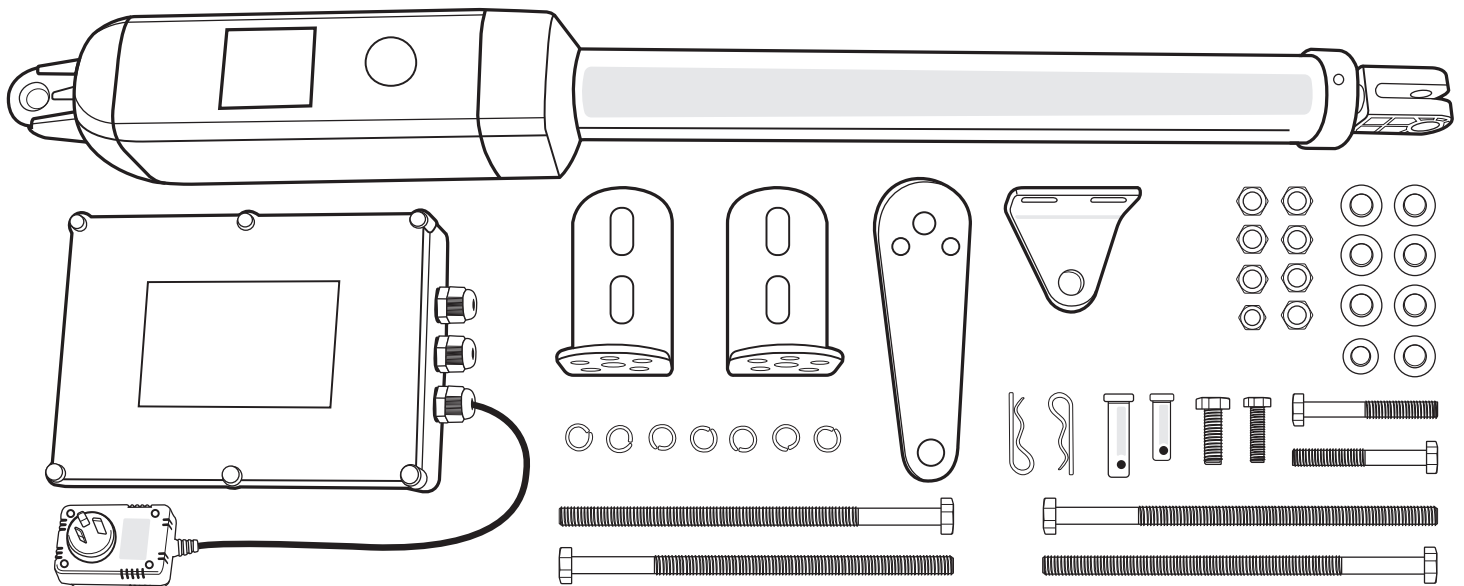

- Please read and follow all warnings, precautions and instructions before installation and use
- 2 x 12V 7Ah batteries are supplied. The AC adaptor included in the package is used to charge the batteries.
- Never connect the solar panel to the control board directly to charge the battery
- Periodic checks of the operator are required to ensure safe operation
- Save this manual

Table of Contents

| | |
|---|----|
| Safety Installation Information..... | 1 |
| Parts List..... | 2 |
| Optional Accessories Parts List..... | 3 |
| Tools Needed: | 3 |
| Technical Specifications & Features | 4 |
| Installation Overview | 4 |
| Preparation for Installation | 7 |
| Install the Gate Opener on the Gate | 8 |
| Mounting of the control box..... | 13 |
| Connection of the power supply..... | 13 |
| Connection of the control board..... | 15 |
| How to Program the Remote to the Opener | 17 |
| How to Erase All the Remote Codes..... | 18 |
| Setting of the Control Board..... | 18 |
| Trouble Shooting | 20 |

Safety Installation Information

1. READ and FOLLOW all instruction.
2. The gate opener is intended for use with Class I vehicular swing gates.

Class I denotes a vehicular gate opener (or system) dwellings, or a garage or parking area associated therewith.

Install the gate opener only when the opener is appropriate for the construction and the usage class of the gate.

3. Gate opening system designers, installers and users must take into account the possible hazards associated with each individual application. Improperly designed, installed or maintained systems can create risks for the user as well as the bystander. Gate system design and installation must reduce public exposure to potential hazards. All exposed pinch points must be eliminated or guarded.

4. A gate opener can create high levels of force during normal operation. Therefore, safety features must be incorporated into every installation. Specific safety features include safety sensors.

5. The gate must be properly installed and work freely in both directions prior to the installation of the gate opener.

6. The gate must be installed in a location so that enough clearance is provided between the gate and adjacent structure when opening and closing to reduce the risk of entrapment. Swinging gates shall not open into public access areas.

7. The opener is intended for use only on gates used for vehicles. Pedestrians must be supplied with a separate access opening. The pedestrian access opening shall be designed to promote pedestrian usage. The pedestrian access shall be located such that persons will not come in contact with the moving vehicular gate.

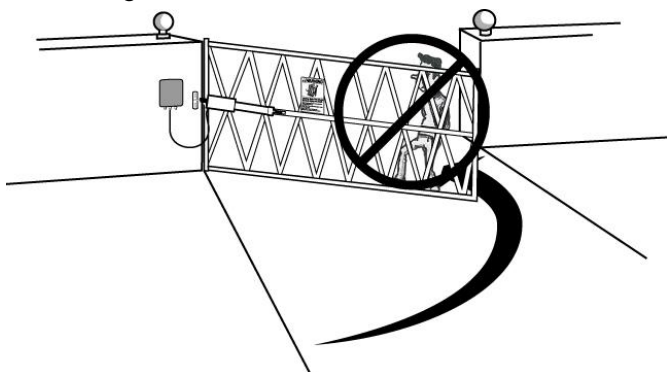

8. Pedestrians should never cross the pathway of a moving gate. The gate opener is not acceptable for

use on any pedestrian gate. Pedestrians must be supplied with a separate pedestrian access.

9. For an installation utilizing non-contact sensors (safety sensors), see product manual on the placement of non-contact sensors (safety sensors) for each type of application.

- a. Care shall be exercised to reduce the risk of nuisance tripping, such as when a vehicle trips the safety sensor while the gate is still moving.

- b. One or more non-contact sensors (safety sensors) shall be located where the risk of entrapment of obstruction exists, such as the perimeter reachable by a moving gate or barrier.

10. Never mount any device that operates the gate opener where the user can reach over, under, around or through the gate to operate the controls. Controls are to be placed at least 6' (1.8m) from any part of the moving gate.

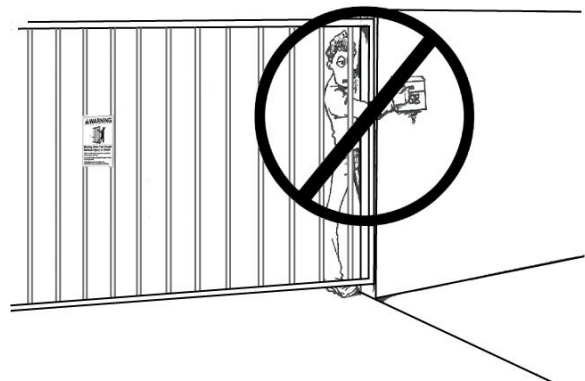

11. Controls intended to be used to reset an operator after 2 sequential activations of the entrapment protection device or devices must be located in the line of sight of the gate, or easily accessible controls shall have a security feature to prevent unauthorized use. Never allow anyone to hang on or ride the gate during the entire travel of the gate.

12. Each gate opener is provided with two safety warning placards. The placards are to be installed on the front and back of the gate where they are plainly visible. The placards may be mounted using cable ties through the four holes provided on each placard.

All warning signs and placards must be installed where visible in the area of the gate.

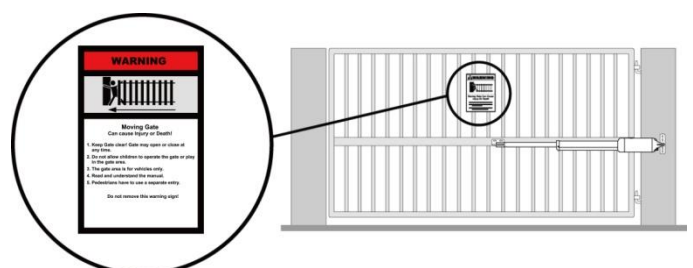

13. To AVOID damaging gas, power, or other underground utility lines, contact underground utility locating companies BEFORE digging.
SAVE INSTRUCTION.

| ⚠ WARNING |
|--|
| <p>To prevent SERIOUS INJURY or DEATH from a moving gate:</p> <ul style="list-style-type: none"> • Install warning signs on the front and back of the gate in PLAIN VIEW. • Permanently secure each warning sign in a suitable manner using fastening holes. |

14. Do not permit children to play on or around the gate and keep all controls out of their reach.

Parts List

| | | | | | | |
|---|--|--|--|---|--------------------|--|
| | |  | | | Gate Opener (1 pc) | |
|  | |  | |  | | |
| | | CE Remote Control (1 pcs) | | | | |
| Control Box (1 pc) | |  | | Release Key (1 pcs) | | |
|  | |  | |  | | |
| AC Transformer (1 pc) | | Battery Cable (1 pc) | | Post Bracket (2 pcs) | | |
| | |  | |  | | |
| | | Post Pivot Bracket (1 pc) | | Gate Bracket (1 pc) | | |
| Hardware | | | | | | |
|  | |  | | | | |
| Φ10 Washer (7 pcs) | | M10×200 Bolt (4 pcs) | | | | |
|  | |  | | | | |
| Φ10 Lock Washer (7 pcs) | | M10×75 Bolt (2 pcs) | | | | |
|  | |  | | | | |
| Φ8 Washer (1 pc) | | M10×30 Bolt (1 pc) | | | | |
|  | |  | | | | |
| M10 Nut (7 pcs) | | M8×30 Bolt (1 pc) | | | | |
|  | |  | | | | |
| M8 Nut (1 pc) | | 12×40 Clevis Pin (1 pc) | | | | |
|  | |  | | | | |
| Hairpin Clip (2 pcs) | | 12×30 Clevis Pin (1 pcs) | | | | |

Optional Accessories Parts List

Optional

| | | | |
|--|---|---|---|
|  <p>Electric Lock (1 set) (LM149)</p> |  <p>Photocell Beam System (1 set) (GTR051)</p> |  <p>Exit Wand (1 pc) (GTR147)</p> |  <p>Back up battery (1 set) (LM125)</p> |
|  <p>Solar Kit (GTR097)</p> | |  <p>Supporting frame for solar panel (1 pc) (LM115)</p> |  <p>Bracket for solar panel (1 pc) (LM116)</p> |
|  <p>Wireless Keypad (1 pc) (GTR120)</p> |  <p>Mounting post for keypad (1 pc) (GTR056)</p> |  <p>Back up battery box(1 pc) (GTR096)</p> | |

Tools Needed:

- Power Drill
- Tape Measure
- Open End Wrenches — 14# & 17# or Adjustable Wrenches
- Wire Strippers
- C-Clamps — small, medium, and large
- Level
- Hacksaw or Heavy Duty Bolt Cutters
- Phillips Screwdriver
- An extra person will be helpful

Technical Specifications & Features

| Specifications | |
|-----------------------|------------------------------|
| | GTR099 |
| Input: | 120V/60Hz or 230V/50Hz |
| Motor voltage: | 24VDC |
| Power: | 80W |
| Current: | 3A |
| Actuator speed: | 16mm/s |
| Max. actuator travel: | 385mm |
| Ambient Temperature: | -20°C~ +50°C (-4°F to 122°F) |
| Protection class: | IP44 |
| | |

Gate Capacity of GTR097

| | | | | | | | | |
|-------------|-------------|-------|-----|-------|-------|-----|-------|----|
| Gate Weight | 380 kg | ✓ | NR | NR | NR | NR | NR | NR |
| | 340 kg | ✓ | ✓ | NR | NR | NR | NR | NR |
| | 300 kg | ✓ | ✓ | ✓ | NR | NR | NR | NR |
| | 250 kg | ✓ | ✓ | ✓ | ✓ | NR | NR | NR |
| | 200 kg | ✓ | ✓ | ✓ | ✓ | ✓ | NR | NR |
| | 160 kg | ✓ | ✓ | ✓ | ✓ | ✓ | ✓ | NR |
| | 110 kg | ✓ | ✓ | ✓ | ✓ | ✓ | ✓ | ✓ |
| | 1.2-1.8 m | 2.4 m | 3 m | 3.6 m | 4.3 m | 5 m | 5.5 m | |
| | Gate Length | | | | | | | |

Features:

- Soft start and soft stop
- Emergency release key in case of power failure
- Fast selecting push/pull to open
- Stop in case of obstruction during gate opening.
- Reverse in case of obstruction during gate closing.

- Built in adjustable auto-close (0-100 seconds)
- Built in max. Motor running time (MRT) for multiple safety protection (40 seconds)
- Reliable electromagnetism limit for easy adjustment
- Can be equipped with a wide range of accessories

Installation Overview

Single Gate Overview

Pull-to-Open Gate

⚠ WARNING

To prevent SERIOUS INJURY or DEATH, at least one non-contact sensor should be located where the risk of entrapment or obstruction exists.

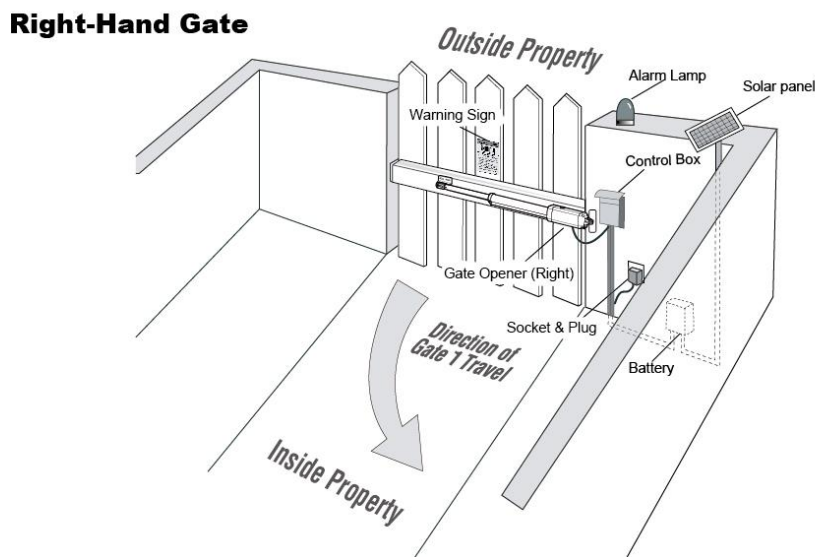
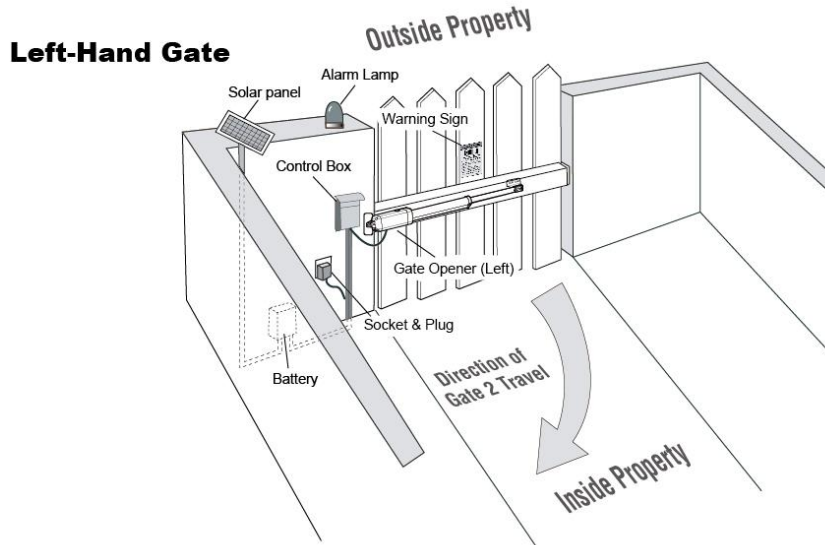

Preparation for Installation

There are two installation types for the gate opener, **Pull-to-Open** and **Push-to-Open**.

In the **Push-to-Open** installation, gate opens out from the property. A Push-To-Open Bracket (**PSO part**) is required to be used for each gate.

NOTE: Ensure the gate does not open into public areas.

The gate opener is mounted to the gate and to the gate post. Both round and square posts can be used because the Post Brackets are curved. When mounting the Post Brackets, use bolts long enough to pass through the entire post. M10 x 200 bolts are included. Concrete anchors are not provided.

When mounting the Post Brackets to wooden posts, a larger-size washer or metal plate should be used between the bolts and the wooden post to ensure the stability of the fastening hardware. If the post is smaller than 6" diameter or square, it should be made of metal and set in cement to ensure its stability.

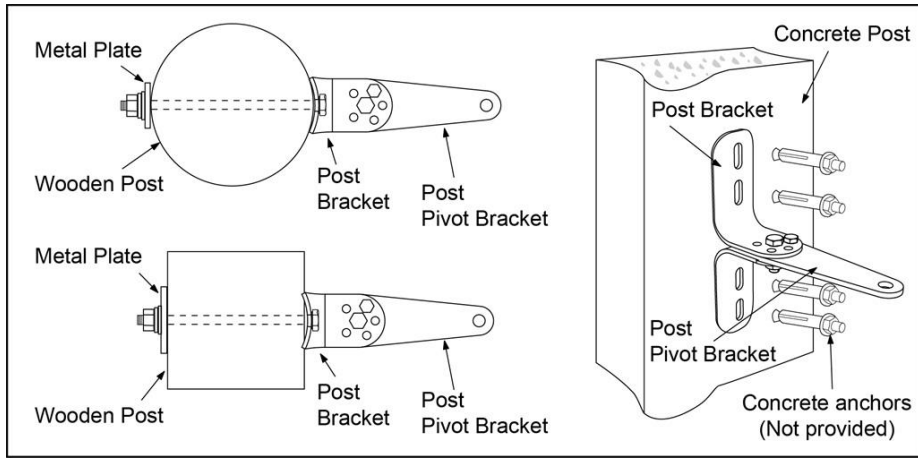

Install the Gate Opener on the Gate

The position of Post Bracket is very important. The following illustrations and tables are required to determine the proper mounting position for the Post Bracket. The tables show the maximum opening angle of the gate for a given A and B. For example, if A is 15cm and B is 20cm, the maximum opening angle of the gate is 110°.

Pull-to-Open Installation — Gate in Closed position (Moving-Rod is extended)

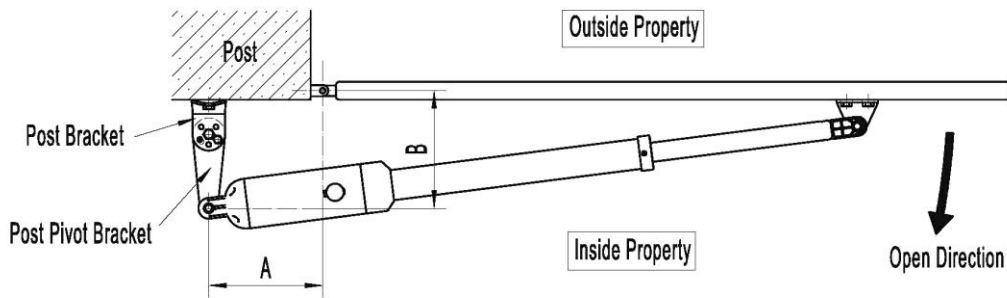

| | A=8cm | A=9cm | A=10cm | A=11cm | A=12cm | A=13cm | A=14cm | A=15cm | A=16cm | A=17cm | A=18cm | A=19cm | A=20cm | A=21cm | A=22cm |
|--------|-------|-------|--------|--------|--------|--------|--------|--------|--------|--------|--------|--------|--------|--------|--------|
| B=19cm | 90° | 93° | 96° | 98° | 101° | 104° | 106° | 108° | 110° | 105° | 102° | 98° | 95° | 93° | 91° |
| B=20cm | 91° | 93° | 95° | 98° | 100° | 103° | 107° | 110° | 104° | 99° | 96° | 94° | 92° | 90° | 89° |
| B=21cm | 91° | 93° | 95° | 97° | 100° | 103° | 106° | 103° | 99° | 96° | 93° | 91° | 89° | 88° | |
| B=22cm | 91° | 94° | 95° | 97° | 99° | 101° | 103° | 98° | 95° | 92° | 90° | 89° | 87° | | |
| B=23cm | 92° | 94° | 96° | 98° | 100° | 103° | 98° | 94° | 92° | 90° | 88° | 86° | | | |
| B=24cm | 90° | 92° | 95° | 97° | 99° | 97° | 93° | 91° | 88° | 87° | 85° | | | | |
| B=25cm | 90° | 92° | 94° | 97° | 96° | 92° | 90° | 87° | 85° | 84° | | | | | |
| B=26cm | 90° | 92° | 94° | 95° | 91° | 88° | 86° | 84° | | | | | | | |
| B=27cm | 90° | 92° | 95° | 90° | 87° | 85° | | | | | | | | | |
| B=28cm | 90° | 93° | 89° | 86° | 84° | | | | | | | | | | |

Please Note: Each swing arm contains an internal thread that may separate if over extended. If overextended “Click” may be heard, to re-connect push and screw the sliding arm Clockwise until the arm begins to retract by hand.

Push-to-Open Installation — Gate in Closed position (Moving-Rod is retracted)

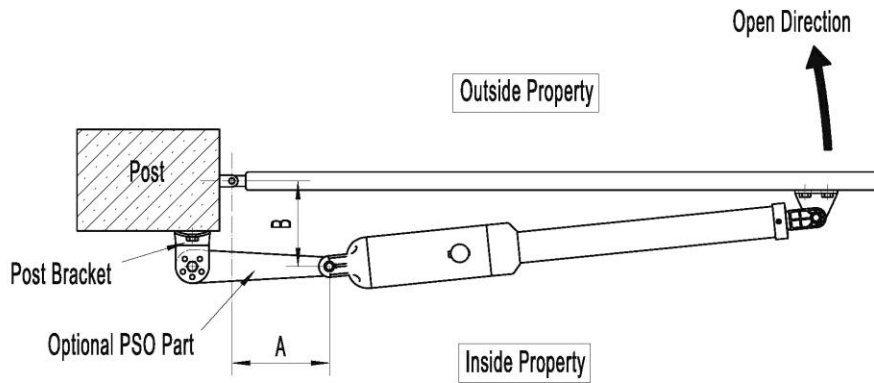

| | A=10cm | A=12cm | A=14cm | A=16cm | A=18cm | A=20cm | A=22cm | A=24cm | A=26cm |
|--------|--------|--------|--------|--------|--------|--------|--------|--------|--------|
| B=9cm | 90° | 100° | 111° | 120° | 125° | 117° | 108° | 99° | 90° |
| B=11cm | 90° | 98° | 107° | 115° | 120° | 111° | 100° | 92° | 86° |
| B=13cm | 90° | 97° | 104° | 110° | 114° | 104° | 94° | 87° | |
| B=15cm | 90° | 98° | 105° | 112° | 109° | 97° | 89° | | |
| B=17cm | 90° | 96° | 101° | 108° | 101° | 91° | 83° | | |
| B=19cm | 90° | 95° | 100° | 106° | 93° | 85° | | | |
| B=21cm | 90° | 94° | 99° | 97° | 87° | | | | |
| B=23cm | 90° | 93° | 97° | 90° | 81° | | | | |
| B=25cm | 90° | 93° | 94° | 83° | | | | | |
| B=27cm | 90° | 92° | 86° | | | | | | |

1. Insert the M10 x 30 bolt through the center hole of the post bracket and post pivot bracket as shown. Place a ϕ 10 washer, ϕ 10 lock washer and M10 nut on the bottom of the bolt and hand tighten.

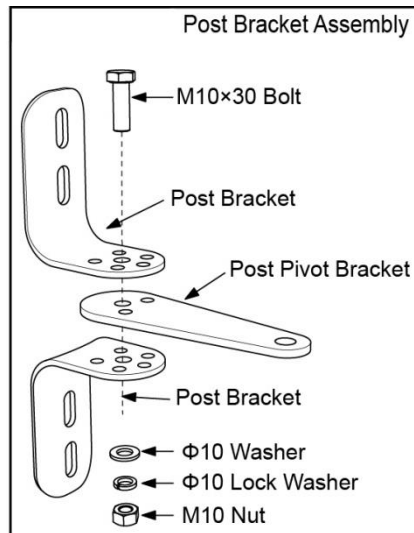

2. Attach the gate bracket and post bracket assembly to the opener by inserting a clevis pin. Secure the clevis pins using the hairpin clips.

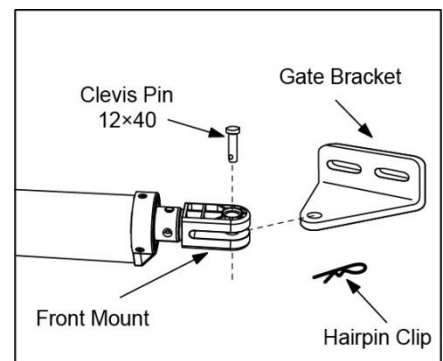
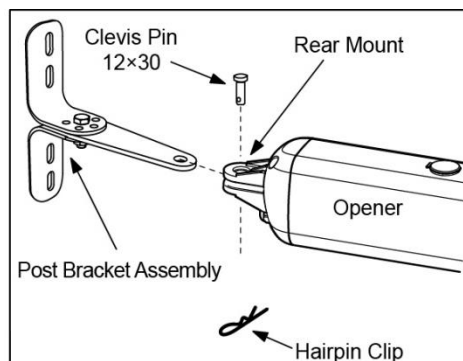

3. Open the release hole plug on the top of the gate opener, insert the release key, and turn the key 90° clockwise. This releases the motor and allows the push-pull rod to be manually extended and retracted. To restore normal operation, turn the key 90° counterclockwise.

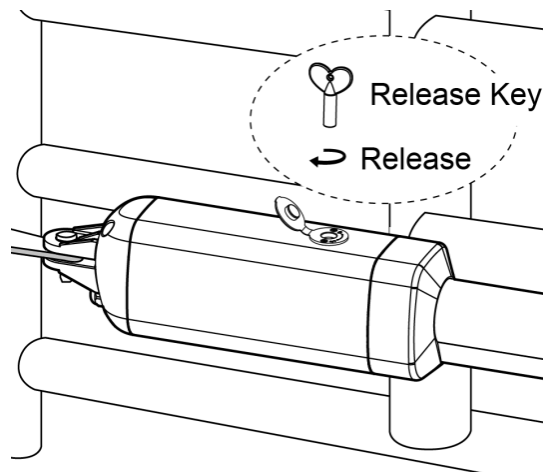

4. With the opener fully retracted and with the gate in the fully open position (for Pull-to-Open installation) or fully closed position (for Push-to-Open installation), place the gate opener with the Post Bracket Assembly and Gate Bracket on the gate post and the gate. Position the Post Bracket Assembly and Gate Bracket so that the gate opener is level.

While holding the gate opener in the level position, temporarily secure it with two C-clamps.

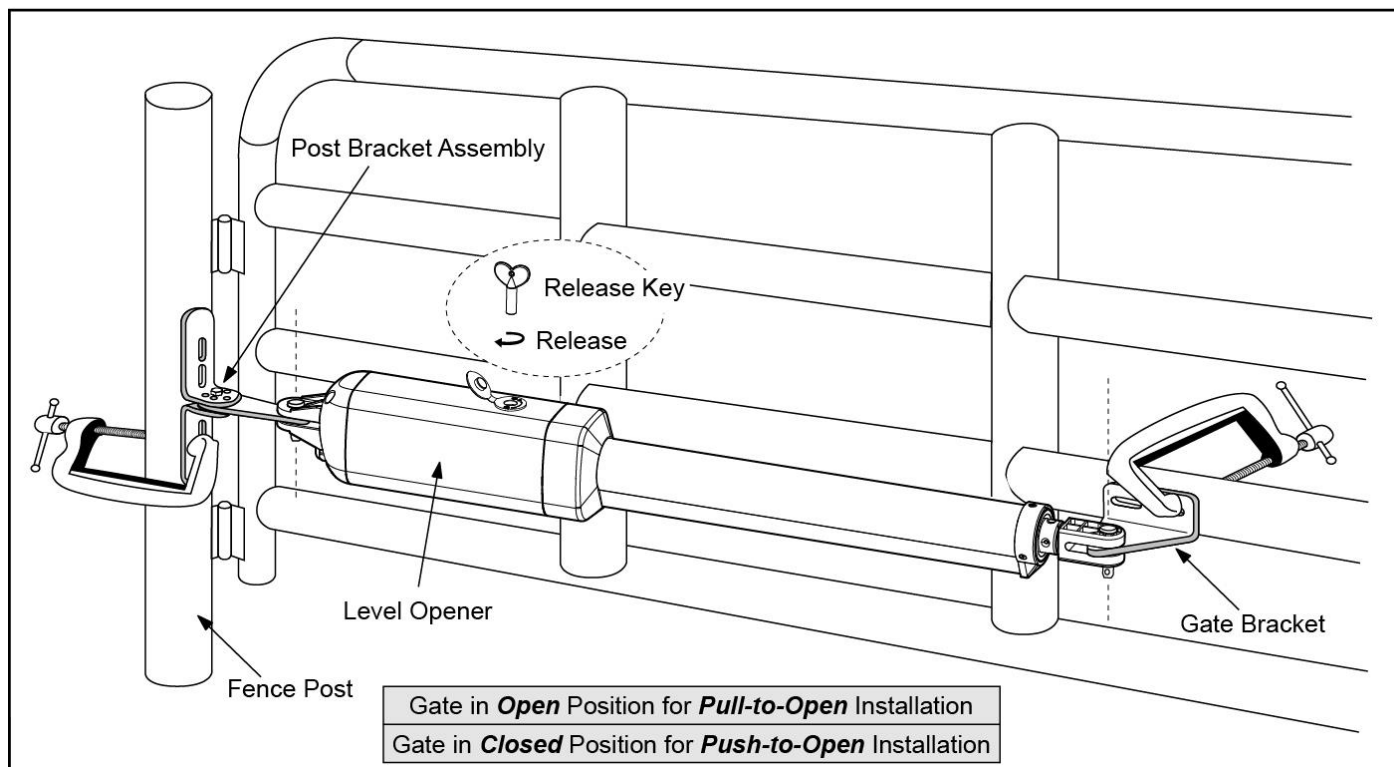

5. Make sure that there is a minimum clearance of 2.5cm between the gate and the opener and that the opener and the Post Pivot Bracket are not binding in both the gate-open and gate-closed positions. If there is not at least 2.5cm of clearance or if the opener and the Post Pivot Bracket are binding, rotate the Post Pivot Bracket and/or move the Post Bracket Assembly to obtain the minimum clearance and eliminate the binding. When the minimum clearance has been obtained and any binding has been eliminated, place the M8 x 30 bolt through the aligned holes in the Post Bracket and the Post Pivot Bracket.

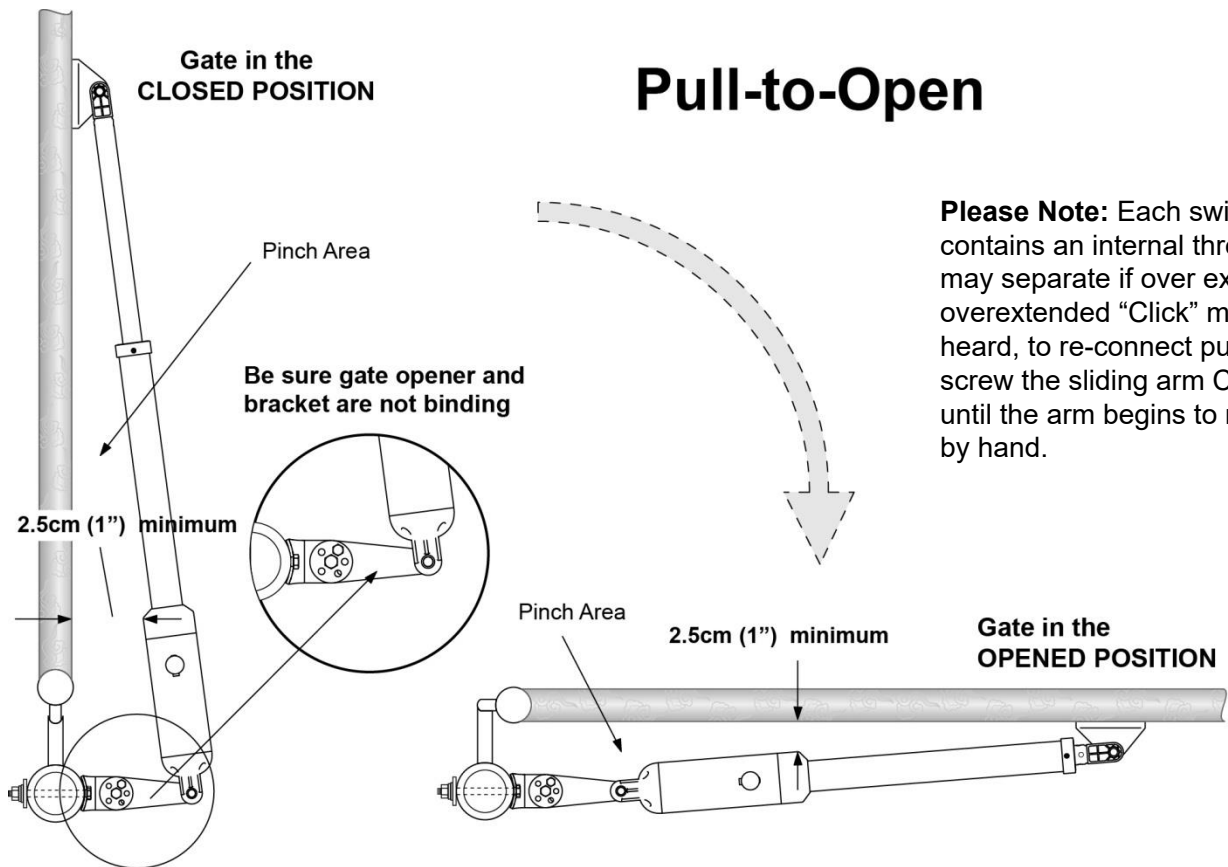

Please Note: Each swing arm contains an internal thread that may separate if over extended. If overextended "Click" may be heard, to re-connect push and screw the sliding arm Clockwise until the arm begins to retract by hand.

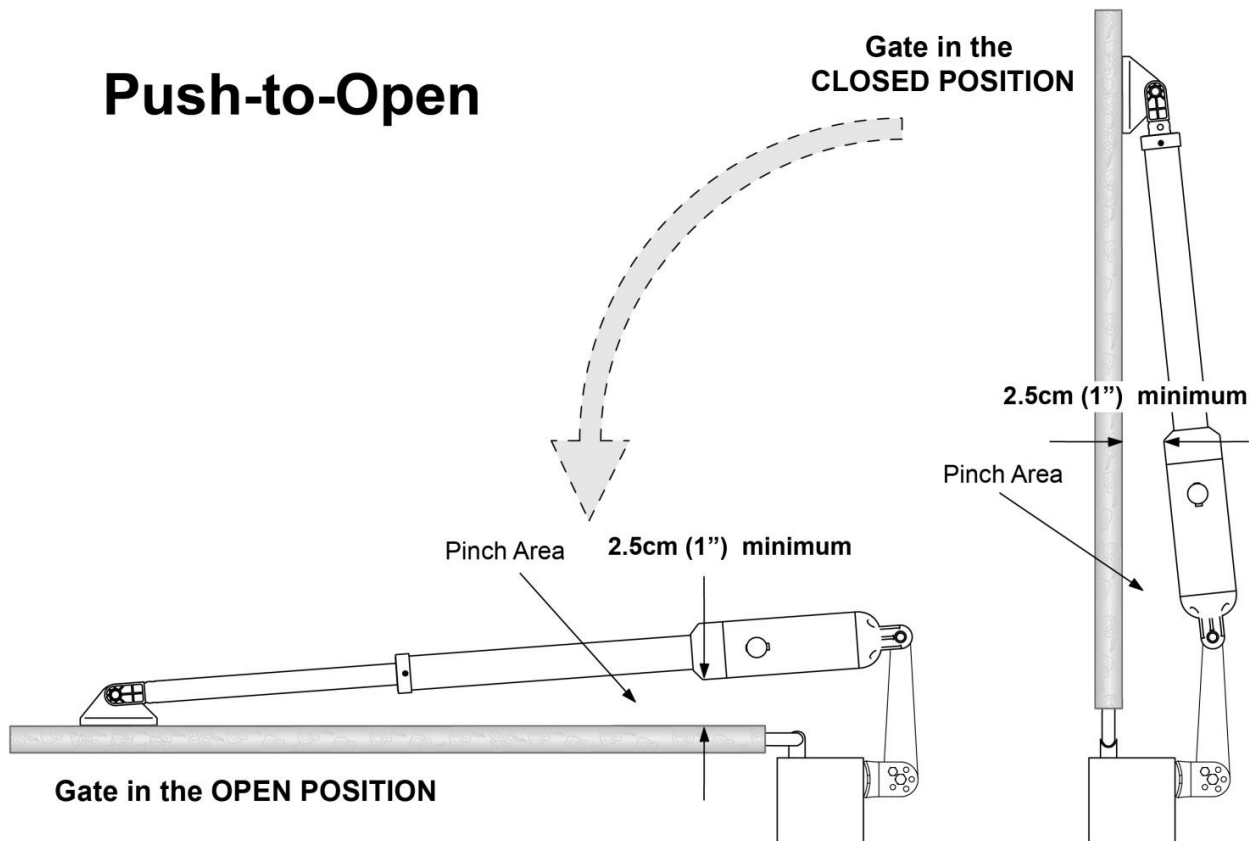

6. Sign the bolt-hole point on the gate bracket and gate. Do this by placing a punch or a sign in the middle of each bolt slot on the post bracket assemblies and the gate bracket. It allows slight adjustments to the post bracket. Then remove the post bracket and gate bracket by taking off the C-clamps.

7. Drill 10.5 mm diameter holes through the post and the gate at the marked locations.

8. Attach the post bracket assemblies to the gate posts by inserting M10 x 200 bolts through each post bracket assembly and the drilled holes in the gate post. Fasten each bolt with one \varnothing 10 washer, one \varnothing 10 lock washer, and one \varnothing 10 nut.

9. Attach the gate brackets to each gate by inserting two M10 x 75 bolts through the gate brackets and the drilled holes in the gates. Fasten each bolt with one \varnothing 10 lock washer, and one \varnothing 10 nut.

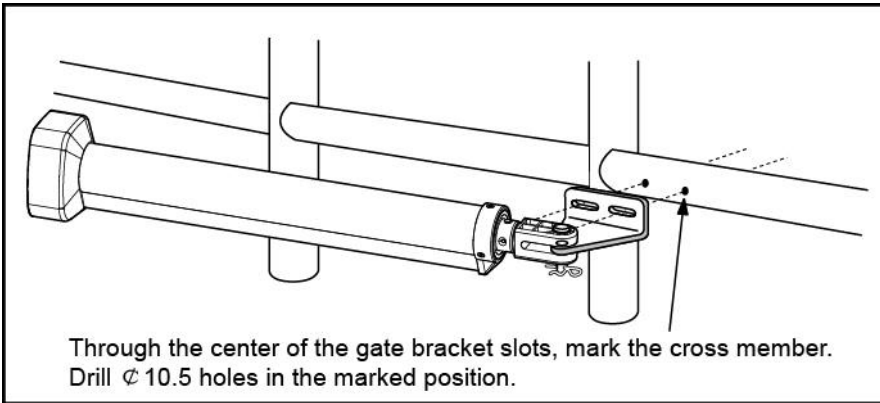
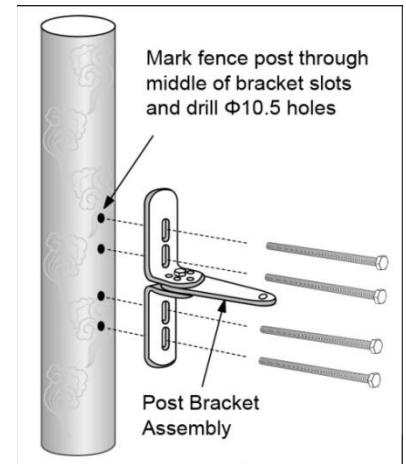

10. Cut off any part of the bolts that extend beyond the tightened nuts.

11. With the gate opener fully retracted and with the gate in the fully open position (for Pull-to-Open installation) or fully closed position (for Push-to-Open installation), attach the gate opener to the Post Bracket Assembly and the Gate Bracket by inserting a clevis pin through the gate opener and the Post Pivot Bracket and another clevis pin through the gate opener and the Gate Bracket. Secure each clevis pin with a hairpin clip.

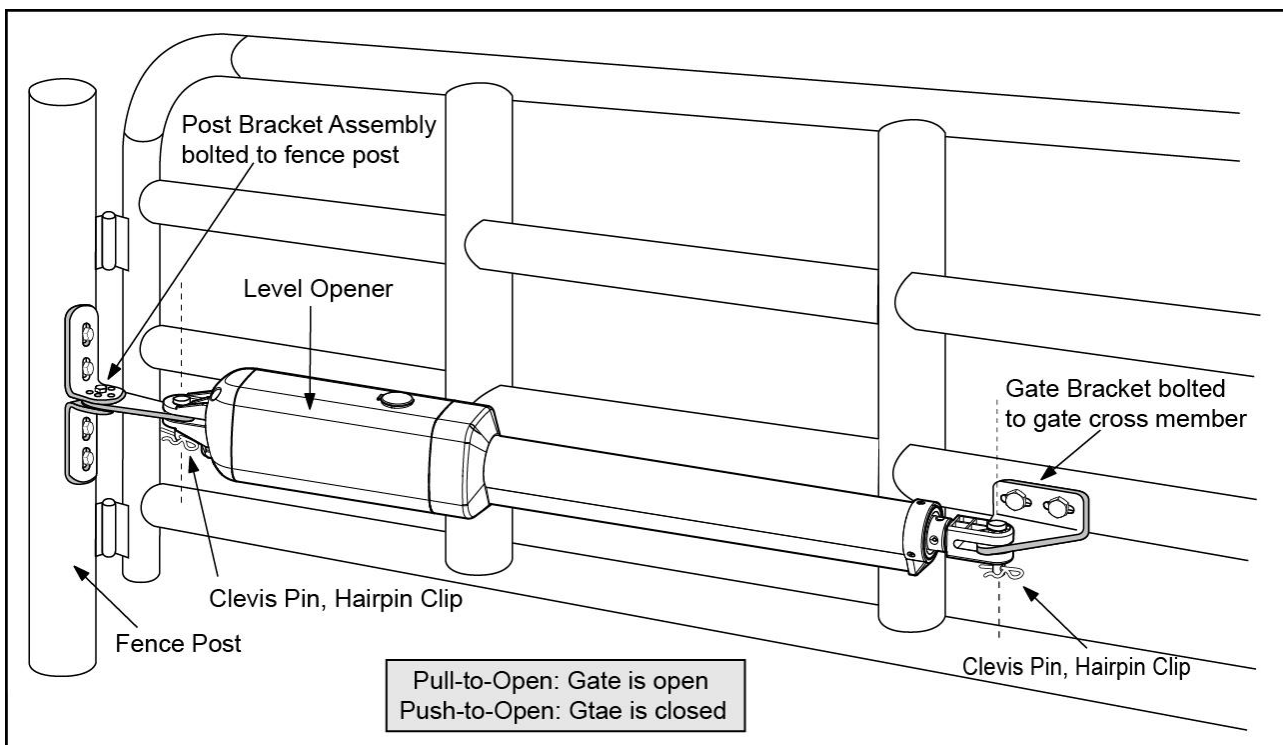

12. Open the release hole plug on the top of the gate opener, insert the release key, and turn the key 90° counterclockwise. This restores normal operation.

Mounting of the control box

Remove the cover of the control box and use 4 deck screws(not provided) to install the control box. Ensure the control box is installed in a secure surface and at least 100 cm (40 inches) above the ground to protect it from rain, snow, etc. which probably cause damage to the control box.

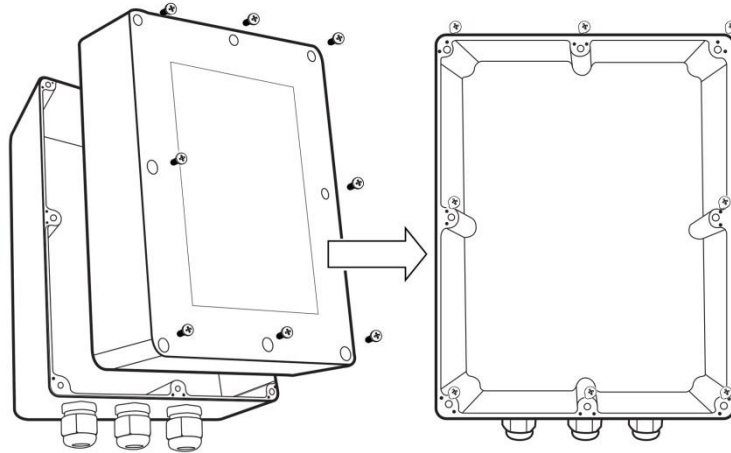

Connection of the power supply

⚠ The gate opener is powered by 24VDC battery. 24VDC battery is required to be installed with the gate opener. You can connect 2 PCS 12VDC battery in series to become 24VDC. For most applications we recommend using 2 x 12V 7Ah batteries. For larger or more frequently opened gates, larger batteries may be required. The following diagram will show you how to connect 2 PCS batteries in series. The charging type could be either AC transformer or solar panel. Also the two can charge the battery at the same time. Please note the wire connection of them is very important. Incorrect wire connection will damage the control board.

⚠ The battery should be waterproof type or you should place them in a waterproof case.

⚠ Please ensure other wire connections are completed before connecting the power supply.

Please refer to the illustration “wire connection of the control board” to connect the battery and AC transformer to the control board. The “24V+” of the battery should be wired to the **BAT+ (#11)** terminal, “24V-” should be wired to “**BAT- (#12)** terminal. **The wire(2*0.75mm², 2meters long) for connecting the battery has been provided and connected to the control board in factory.** AC transformer is supplied wired to the “**AC24V(#13,#14)** terminals of the control board.

The length of the wire of the transformer is 1.5m(5’). So if the distance between the outlet and the control box is longer than that, you should use an extended wire to connect the transformer to the control board. The wire size should be at least 16AWG. If the distance is more than 100m(300’), the wire size should be at least 14AWG. The maximum distance from the transformer to the control box is 300m(1000’).

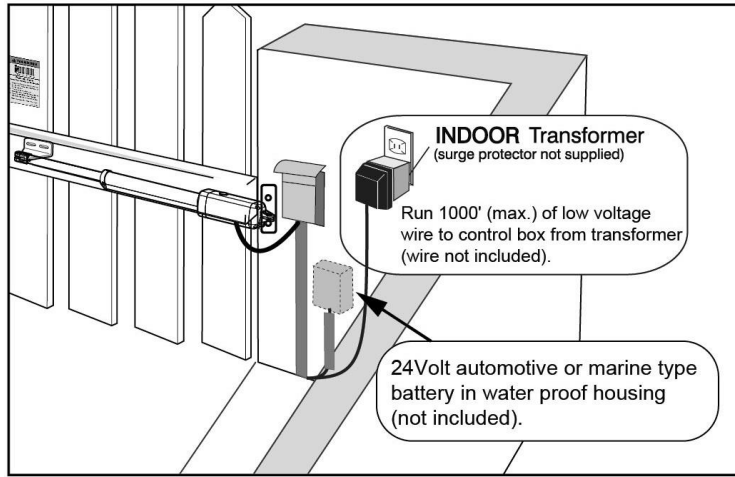

If you want to use an optional solar panel to charge the battery, you can purchase the GTR097 Solar Kit, which contains a solar panel, solar regulator and all connecting cables. To connect the solar panel and the solar charge controller refer to the manual of the GTR097 as well as the following illustration.

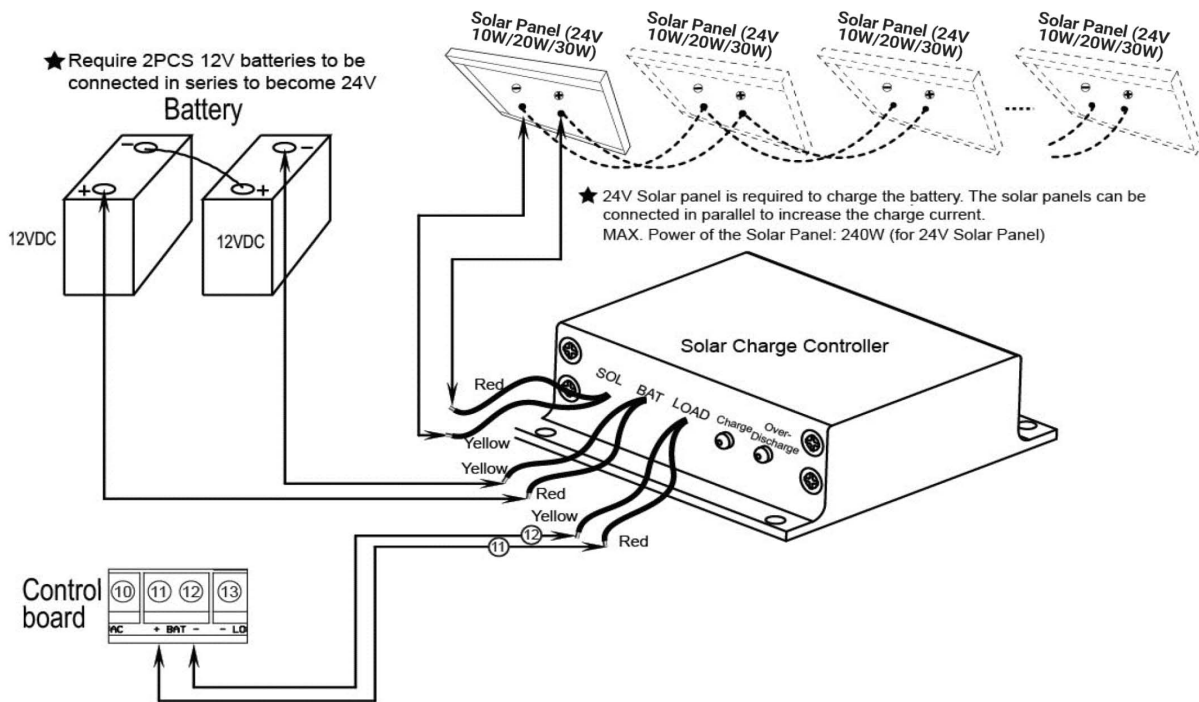

You can plug the transformer into the electrical outlet after all the wire connections are completed. Use a surge protector with the transformer is strongly recommended. If electrical outlet is located outdoors, outlet and transformer must be protected by a weatherproof cover. All work with mains power must be done by a qualified electrician.

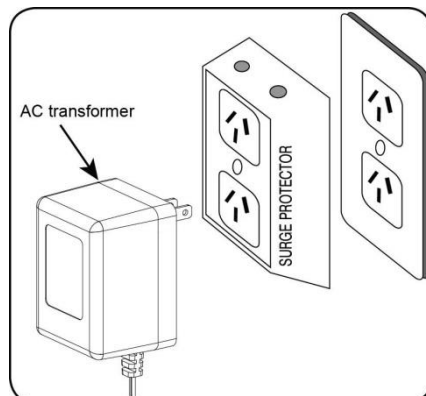

Connection of the control board

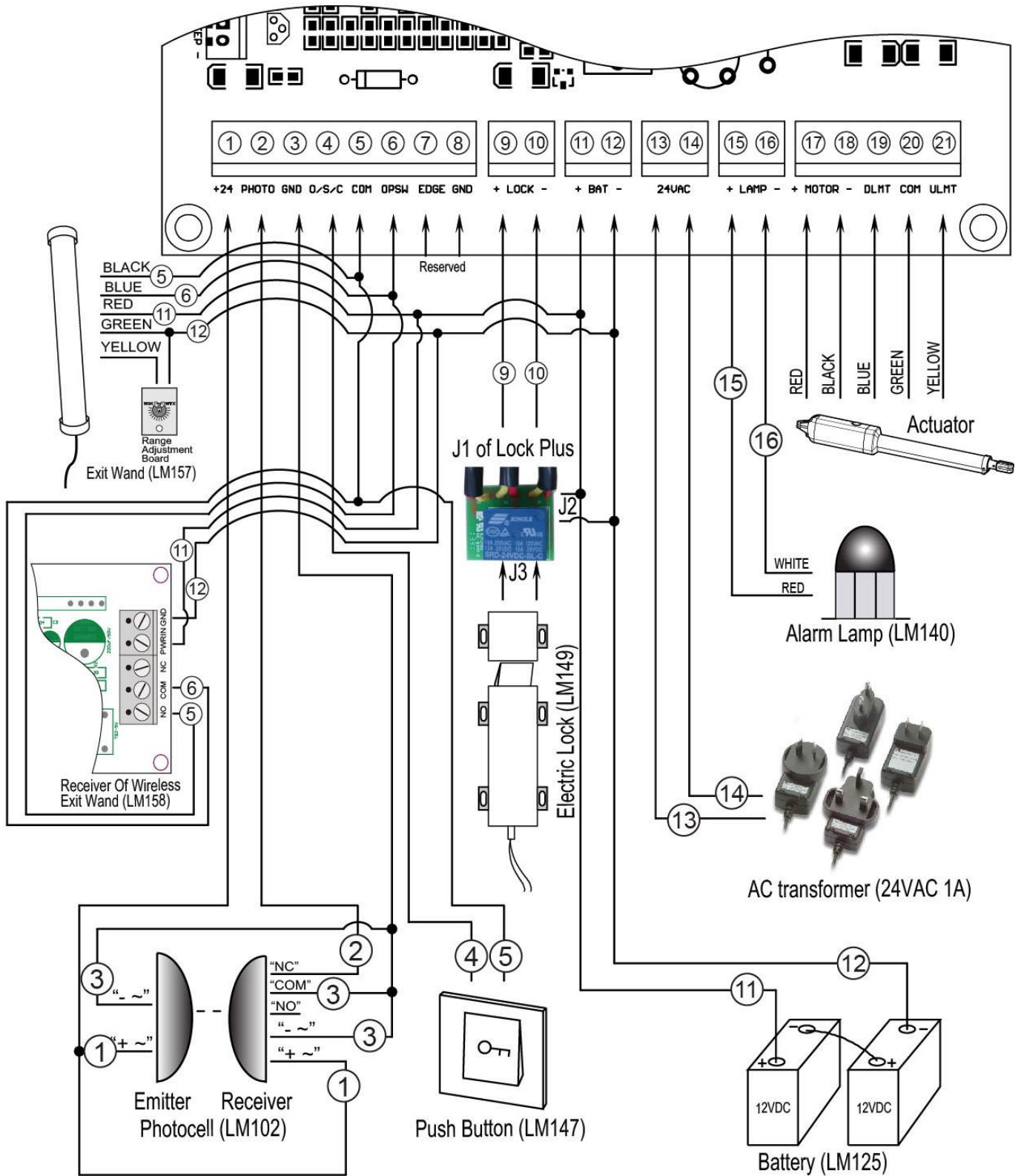

Connecting wires using screw-type terminals

To connect to any of the screw type terminals on the circuit board, you will need to firmly pull the green terminal off the circuit board, and use a small screwdriver to loosen the screw. Make sure the wire is cleanly twisted, and there are no frayed wires sticking out. Feed the wire into the required terminal, ensuring full contact with the metal. Retighten the screws, and then tug on the wire to ensure that it is securely fastened. Once all wires are inserted and fastened, push the green terminal back into the circuit board, making sure it clicks in and is sitting flush. Lastly, check that the wires are not contacting a neighboring terminal as this can cause a short circuit.

1. Actuator

Insert the stripped cable wires into the appropriate terminals on the opener terminals block. The **red** wire should be inserted into the “**+MOTOR**” terminal(#17), the **black** wire into “**MOTOR-**” terminal (#18), the **blue** wire into “**DLMT**” terminal(#19), the **green** wire into “**COM**” terminal(#20), and the **yellow** wire into “**ULMT**” terminal (#21).

2. Battery (optional)

The “**24V+**” of the battery should be wired to the **+BAT** (#11) terminal, “**24V-**” should be wired to “**BAT-**” (#12) terminal.

3. AC transformer

Insert the stripped cable wires into **AC24V**(#13) terminals to the control board. No matter the polarity.

4. Alarm Lamp (optional)

The red wire of the alarm lamp should be inserted into either **LAMP (#15)** terminal, the white wire into the other one (#16).

5. Photocell Beam System (PBS) (optional)

Use a 2-core cable to connect the “**+ ~**” terminal of the photocell’s emitter to the “**+24**”(#1) terminal, the “**- ~**” terminal to the “**GND**”(#3) terminal. Also the “**+ ~**” and “**- ~**” terminals of the photocell’s receiver should be connected to the “**+24**” and “**GND**” terminals in parallel.

Use another 2-core cable to connect the “**NC**” terminal of the receiver to the “**PHOTO**”(#2) terminal, the “**COM**” terminal to the “**GND**”(#3) terminal.

6. Push Button (optional)

The push button should be wired to the “#4 and #5” terminals. No matter the polarity. The gate operator works alternately by pressing the button (open-stop-close-stop-open).

7. Electric Lock (optional)

A lock plus board (should be purchased separately) is required to connect the electric lock to the control board. The 2 wires of J1 of lock plus should be wired to the “9#” and “10#” terminal of the control board. No matter the polarity. Red wire of J2 should be wired to the 11# terminal and yellow wire of J2 should be wired to the 12# terminal. Red wire of J3 should be connected to the red wire of electric lock and also the yellow wire of J3 should be connected to the yellow wire of electric lock.

8. Exit Wand (optional)

The **BLACK** wire of the exit wand should be connected into the “#5” terminal.

The **BLUE** wire of the exit wand should be connected into the “#6” terminal.

The **RED** wire of the exit wand should be connected into the “#11” terminal.

The **GREEN** wire of the exit wand should be connected into the “#12” terminal.

The sensitivity adjustment board should be wired to the **GREEN** wire and the **YELLOW** wire of the wand. No matter the polarity.

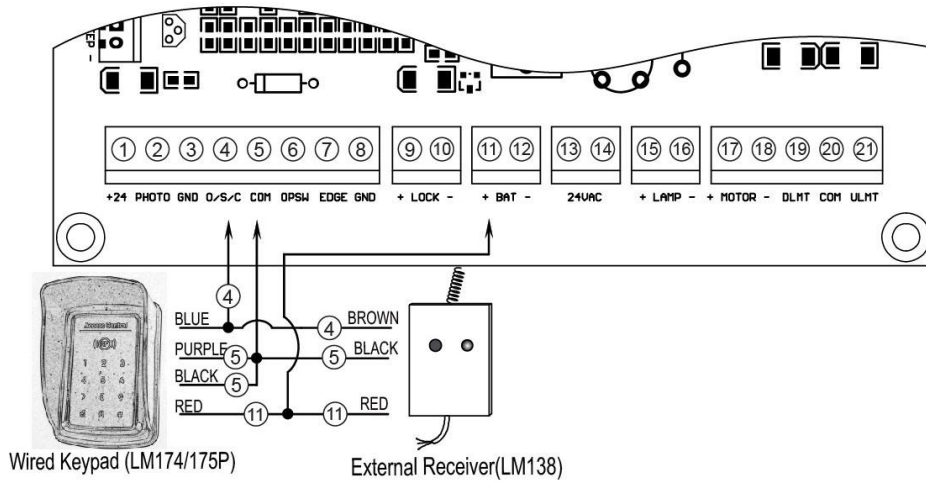

9. Wired Keypad (optional)

The **RED** wire of the wired keypad should be connected into the “#11” terminal.
 The **BLACK** wire of the wired keypad should be connected into the “#5” terminal.
 The **PURPLE** wire of the wired keypad should be connected into the “#5” terminal.
 The **BLUE** wire of the wired keypad should be connected into the “#4” terminal.

10. External receiver (optional)

The **RED** wire of the external receiver should be connected into the “#11” terminal.
 The **BLACK** wire of the external receiver should be connected into the “#5” terminal.
 The **BROWN** wire of the external receiver should be connected into the “#4” terminal.

Note: Using of the exit wand, keypad and external receiver would cause the battery exhausted quickly. Big capacity of battery and big power of solar panel(if the solar panel is used as main charger) is required if you want to use either of them.

How to Program the Remote to the Opener

You must program the remote to the opener before operating. You can follow the below steps to program the remote to the opener.

Press and release the **CODE SW** button, the **CODE LED** will be ON, then press the key in the remote twice in 4 seconds, the **CODE LED** will flash for 3 seconds and then to OFF. Now the remote has been programmed successfully.

NOTE: The button of the remote control should be pressed and hold for more than 2 seconds while programming. Max. 10 remotes can be programmed for the opener. If you want program more remotes, you should use an optional external receiver.

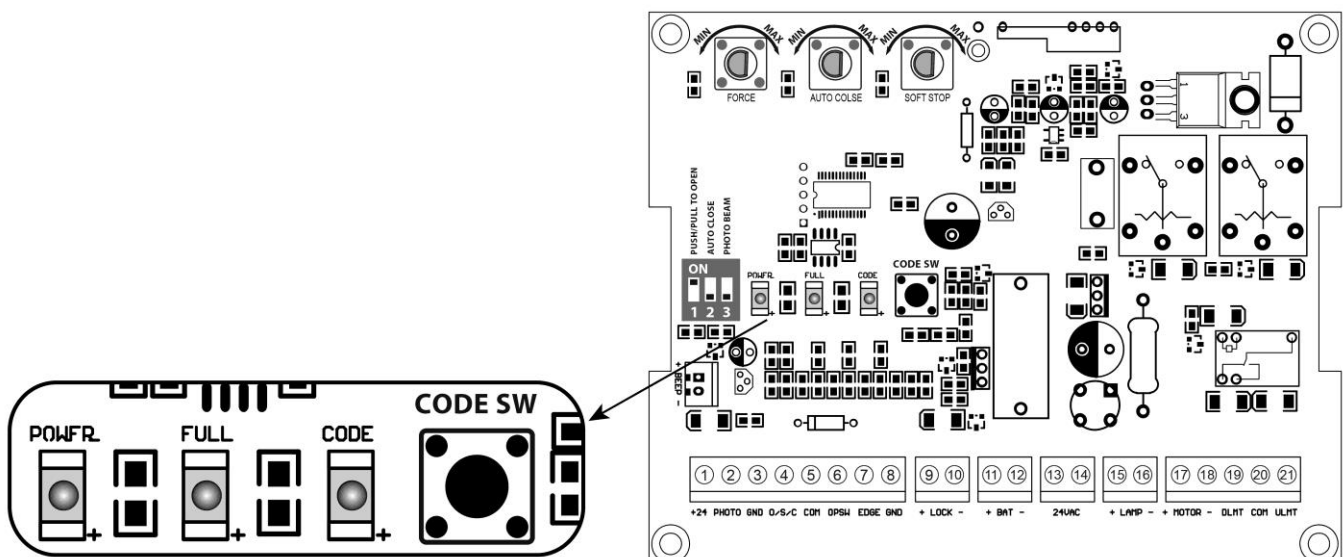

How to Erase All the Remote Codes

Press and hold the **CODE SW** button until the **CODE LED** from ON to OFF. Now all remote codes have been erased.

Setting of the Control Board

⚠ WARNING: Ensure the gate opener is Power Off when you make any adjustment of the gate opener. Keep away from the gate during you set the gate opener system in case of the unexpected gate moving. Carefully adjust the DIP switches to avoid the risk of machine damage and injury or death. Always ask the help of professional technician /electrician if you have any question.

1. DIP Switches

The DIP switches are used to select pull/push to open, enable/disable auto close function, enable/disable photobeam function.

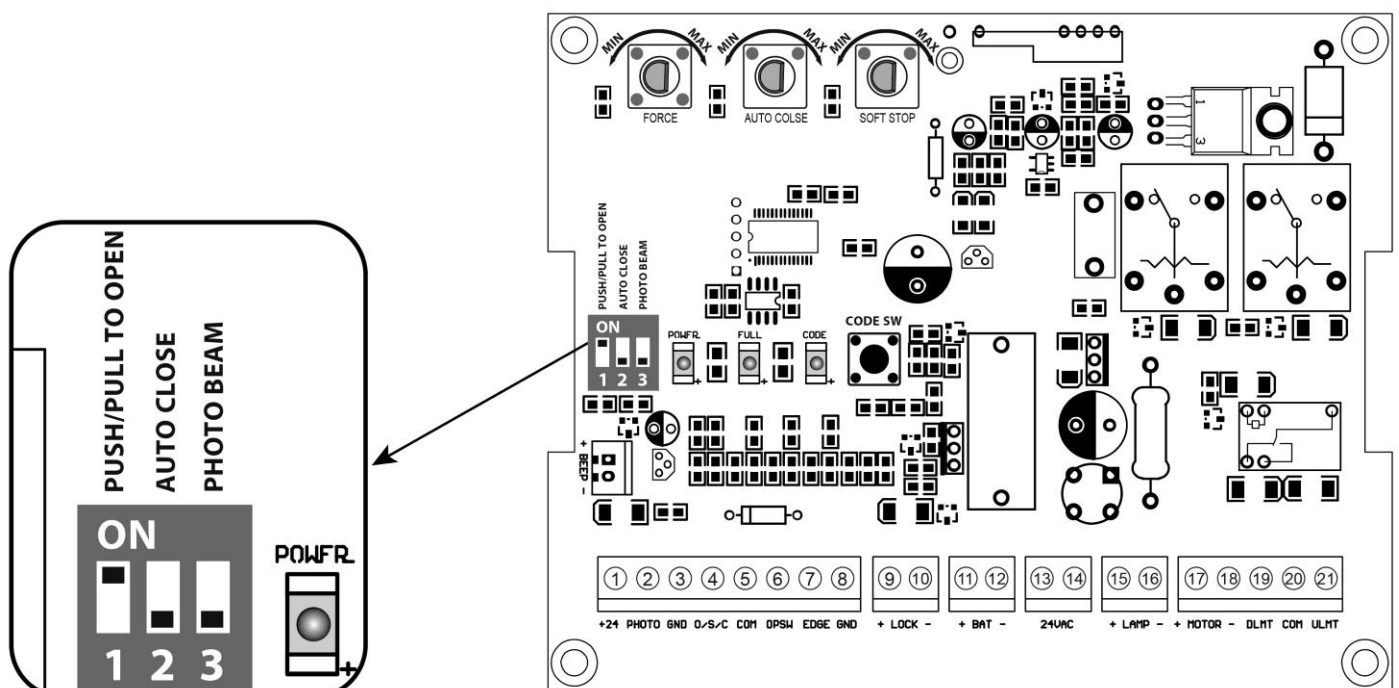

DIP Switch #1: Select push/pull to open

If the gate opens into the property (**pull to open**), the DIP Switch is set to **OFF** (factory default setting). If your gate opens out from the property (**push to open**) the DIP Switch must be set to the **ON** position. Factory default setting is **OFF**.

DIP Switch #2: Auto close function enabled/disabled

ON – Auto close function **enabled**

OFF – Auto close function **disabled**

Set the switch #2 to ON to enable the auto close function. Factory default setting is **OFF**.

DIP Switch #3: Photocell function enabled/disabled

ON – Photocell function **enabled**

OFF – Photocell function **disabled**

You must set the switch #3 to ON to enable the photocell function if you want to use the photocell with the gate opener. Factory default setting is **OFF**.

2. Potentiometers

There are 3 potentiometers located in the control board. They are used to adjust the stall force, auto-close time and soft stop period.

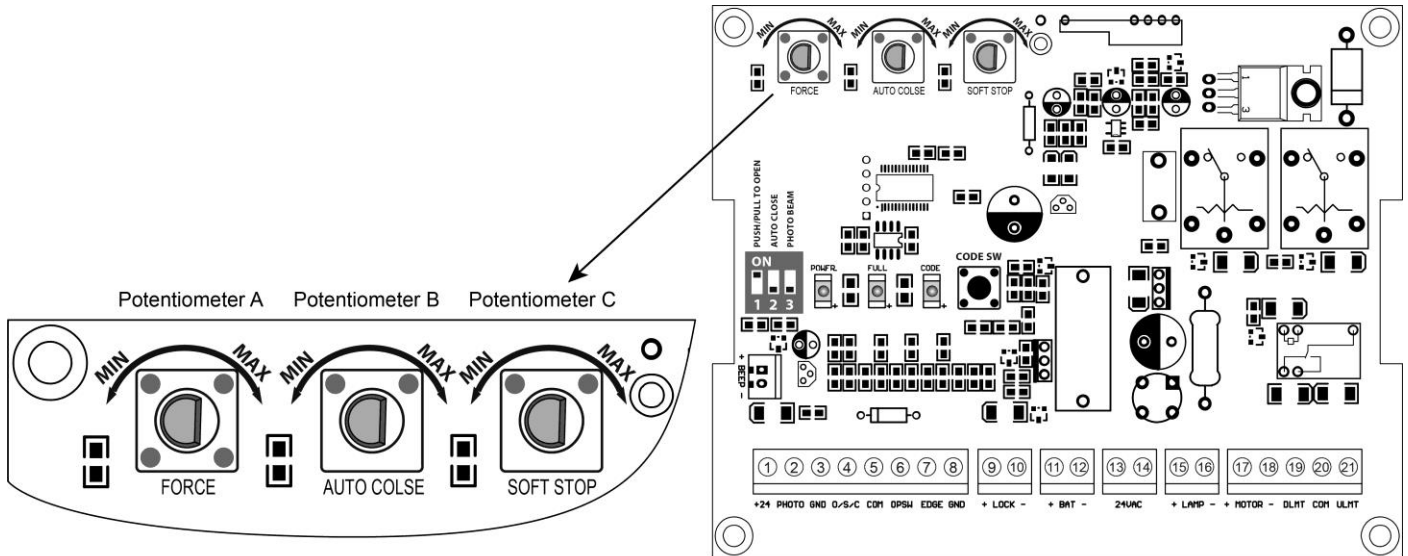

Potentiometer A is used to adjust the stall force the gate opener. Turn the potentiometer clockwise to increase the stall force, and turn it counter-clockwise to decrease the stall force.

Potentiometer B is used to adjust the auto close time of the gate opener. Turn the potentiometer clockwise to increase the auto close time, and turn it counter-clockwise to decrease the auto close time. The auto close time can be adjusted steplessly from 3 to 120 seconds.

Potentiometer C is used to adjust the soft stop period of the gate opener. Turn the potentiometer clockwise to increase the soft stop period, and turn it counter-clockwise to decrease the soft stop period. The auto close time can be adjusted steplessly from 1 to 5 seconds.

Trouble Shooting

Have a multimeter to check voltage and continuity. Use caution when checking high voltage terminals.

| Symptom | Possible Solution(s) |
|--|---|
| The opener does not run. Power LED flash very quickly. | 1. Battery is over-discharged. Check the voltage of the battery. The voltage of the battery should above 22V to make the gate opener work normally. |
| The opener does not run. Power LED does not turn ON. | 1. Make sure the connection between the battery and control board is correct and fastening. 2. Check the fuse in the control board. Replace the fuse if it was burnt out. 3. Check the control board. Replace the control board if necessary. |
| Gate moves a little and then reverse or stop | 1. The selected force is too small to move the gate. Turn the Potentiometer clock-wise to increase the force. 2. Disconnect the gate from the gate operator and check that the gate slides freely without any binding. |
| Gate opener does not run when you press the remote control | 1. Make sure the remote has been programmed to the control board before using. 2. The battery of the remote may be exhausted. If the red light on the remote does not flash when the button is pressed, replace the battery and try it again. 3. Check the control board. Replace the control board if necessary. |
| Gate can open but does not close | 1. Make sure the connection of the photocell beam is not blocked if the photocell is used. 2. Check if the close limit switch is broken. 3. Check the control board. Replace the control board if necessary. |
| Gate automatically opens, but does not automatically close | 1. Setting of DIP switch #1 could be wrong. Please set the dip switch correctly according to the push/pull to opener installation of the gate opener. |
| Gate arm is over-extended and wont retract | 1. Each swing arm contains an internal thread that may separate if over extended. If overextended "Click" may be heard, to re-connect push and screw the sliding arm Clockwise until the arm begins to retract by hand |

For any technical enquiries, please call Richmond Wheel & Castor Co on 1300 474 246 or fill out the support form located at richmondau.com/gate-motor-support



According to Waste of Electrical and Electronic Equipment (WEEE) directive, WEEE should be separately collected and treated. If at any time in future you need to dispose of this product please do NOT dispose of this product with household waste. Please send this product to WEEE collecting points where available.

