

ABS CENTRAL LOCKING TWIN WHEEL SERIES CASTORS



Suitable for patient beds requiring one point locking and minimal maintenance. Richmond's ABS Central Locking Castors are quiet running and feature an attractive appearance, designed to add to the atmosphere of any medical environment.

The stylish ABS cover and precision ball bearing swivel head assist in swivelling the castor, making beds and stretchers easier to position at any time. Load capacities up to 120kg and positive brake performance increase the value this Richmond castor adds to hospital beds.



S6295

S6295B



Diameter (mm)	Width (mm)	Wheel Type	Bearing Type	Load Capacity (kg)	Height (mm)	Stem Diameter (mm)	Swivel Radius	Swivel Code
100	15 x 2	Polyurethane	Ball	120/100	120	32	90	S4298
125	15 x 2	Polyurethane	Ball	120/100	165	28	102	S5296
125	15 x 2	Polyurethane	Ball	120/100	165	32	102	S5298
150	18 x 2	Polyurethane	Ball	150/120	192	28	125	S6296
150	18 x 2	Polyurethane	Ball	150/120	192	32	125	S6298

BRAKE OPTIONS: B = Brake D = Directional Lock

To order castors with Brake or Directional Lock add B or D to end of swivel code e.g. S5296B

ABS Twin Wheel castors with 28mm stem diameter

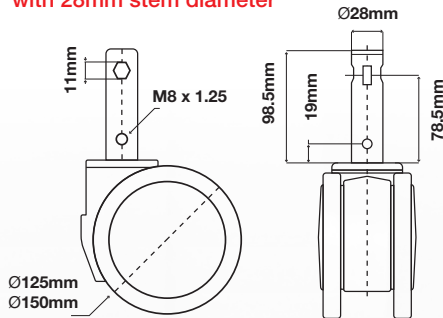

ABS Twin Wheel castors with 32mm stem diameter

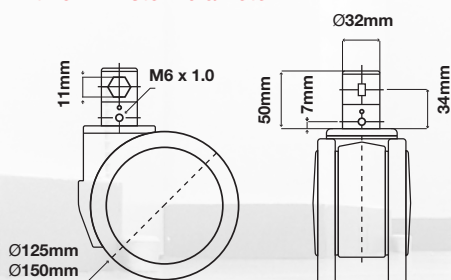

Fine Adjustment for Wheel Lock

Unlock and remove cap to access the adjustment screw for fine tuning the brake tightness.



The markings at the top of the castor stem denote the brake type of that castor



Accessories Available

