

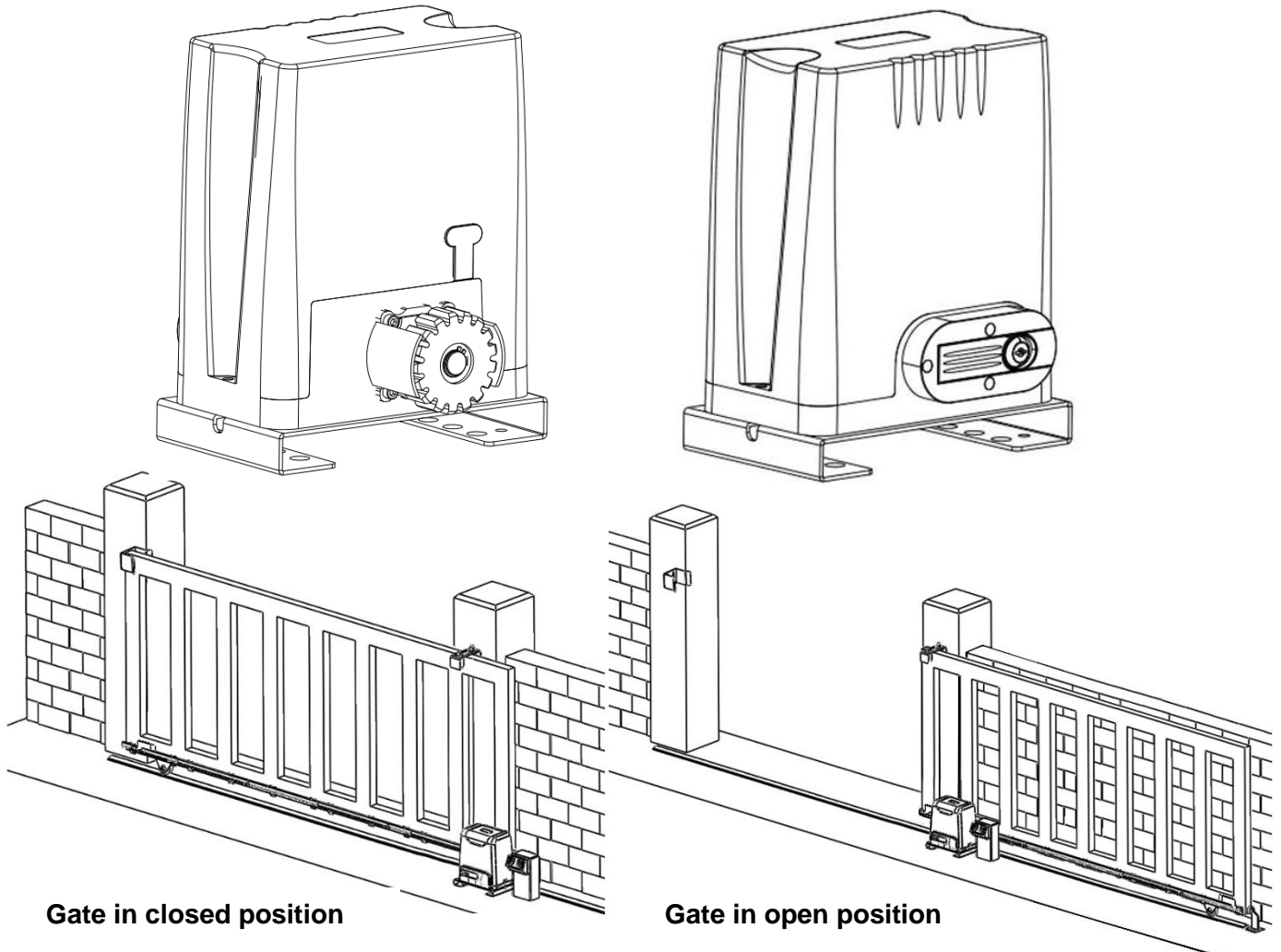

# Sliding Gate Opener User Manual

## Model: GTR064 MKII

Please Note: This motor runs on AC Power as standard but can also be operated by DC Battery Backup or Solar Power.



Gate in closed position

Gate in open position

Viewed from inside the property

### WARNING

Instructions must be read before beginning installation. Please follow these instructions carefully, incorrect installation could affect gate operation. If you require more information, please contact Richmond Wheel & Castor Co on 1300 474 246

**When mounting and positioning the motor ensure that the power cable is unplugged. The motor cover will need to be removed to mount the motor to the mounting plate.**

## **Optional Accessories Available:**

**Additional Remotes (GTR179):** Spare/Additional remotes for the automatic gate kit, these will need to be paired to the motor.

**Wireless Keypad (GTR180):** Allows secure access through the gate used with a user set code.

**Hard Wire Keypad (GTR199):** Allows secure access through the gate used with a user set code.

**Warning Light (GTR198):** Alerts people near the gate and users that the gate is in operation.

**Solar Kits Available:** Solar panels and more available to get this gate kit running on solar power. Please contact your nearest authorised dealer for compatible solar panels in your state/region.

## Contents:

<b>Gate Opening Default Setting Information</b> .....	4
<b>General Safety</b> .....	5
<b>Parts List</b> .....	6
<b>Technical Specifications</b> .....	7
<b>Motor Installation</b>	
Before you start.....	8
Tools Required / Example Sliding Gate Setup.....	9
Step 1 – Gate Preparation.....	10
Step 2 – Motor Pad Footing.....	10
Step 3 - Motor Position Installation.....	11
Step 4 – Drilling Holes for Anchor Bolts.....	11
Step 5 – Fitting the Mounting Plate & Motor.....	12
Step 6 – Gear Rack & Motor Alignment.....	13
Step 7 – Limit Travel Stops.....	15
Step 8 – Powering the Motor.....	17
Step 9 – Testing the Limit Travel Stops.....	18
<b>Programming and Wiring</b>	
Control Board Diagrams.....	19
Dip Switch Adjustment.....	20
Further Settings and Programming.....	21
Connecting Infrared Photocells.....	26
Battery/Solar Connection.....	27
<b>Adding optional functions to your gate</b>	
Automatic close function .....	22
Connecting Infrared Photocells (sold separately) .....	26
Adding a keypad (sold separately).....	22 & 24
Connecting Battery Backup (sold separately) .....	27
Connecting Solar Power (sold separately) .....	28
<b>Maintenance</b> .....	29
<b>Troubleshooting</b> .....	30
<b>Clearing and Pairing Remotes</b> .....	31
<b>Additional Drawings and Diagrams</b> .....	32

## Gate Opening Default Setting Information:

The gate motor will open the gate to the right-hand side as its default setting (refer to fig 1).

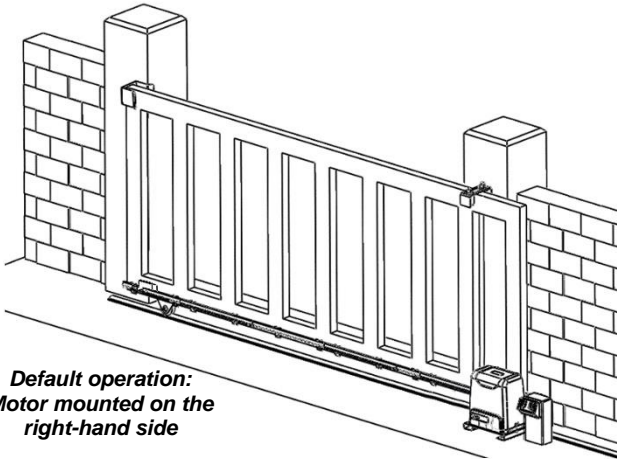

**Default operation:**  
Motor mounted on the  
right-hand side

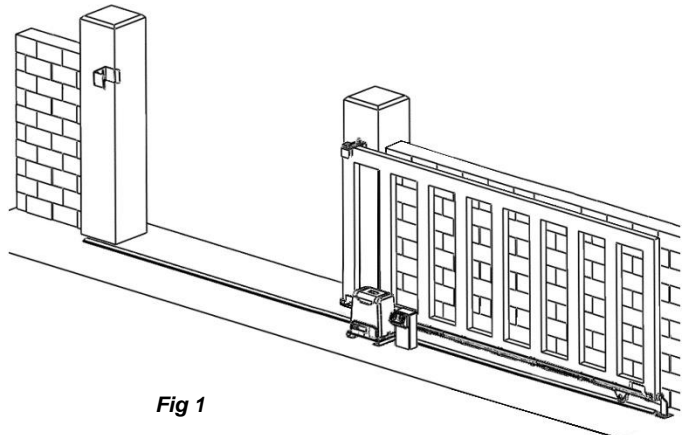
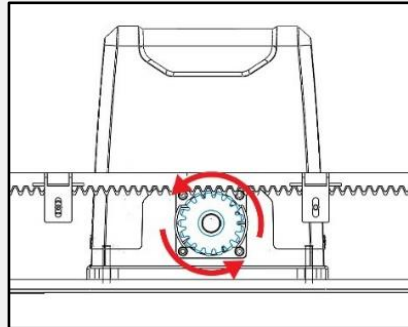

Fig 1

**Before Installing:** Test the motor by plugging it into a power source and pressing the remote. You will see the motor cog turn. When it stops, press the remote again to see it turn in the opposite direction. This will give you an understanding of the way in which the motor will move the gate.



Press the first/top button on the  
remote.



The motor cog will turn counter-  
clockwise, moving the gate frame.

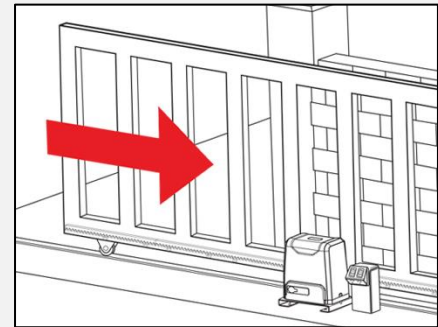

The gate will then move in the set  
direction. Default: right-hand open.

**Note:** Ensure that the motor is unplugged before proceeding with installation. Please keep fingers away from the motor cog whilst it is turning.

If your gate needs to open from the other direction (to the left, refer to fig 2) your motor needs to be mounted on the left-hand side as shown, you will need to switch DIP SWITCH 5 from OFF to ON (refer to page 22) and swap over the CL & OP lines on the J10 terminal (refer to page 24).

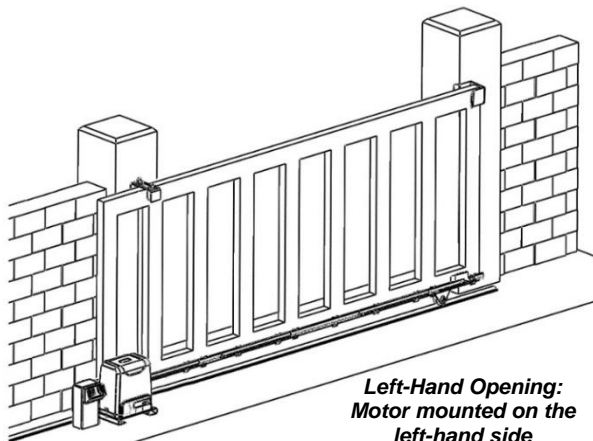

**Left-Hand Opening:**  
Motor mounted on the  
left-hand side

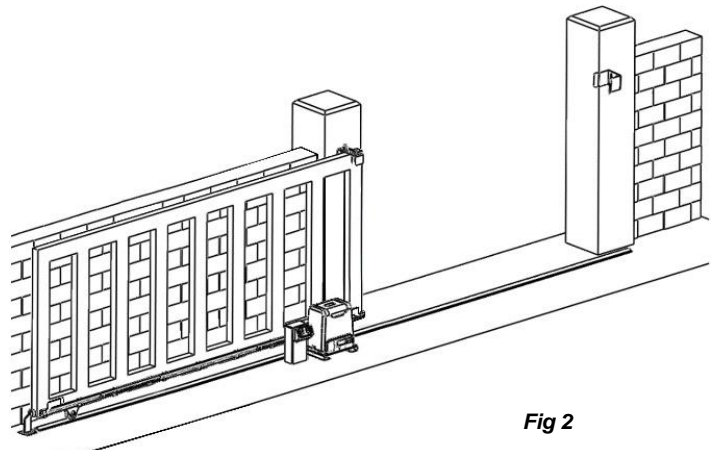

Fig 2

**Any works done to the motor must be completed whilst the power is off, and the motor is unplugged**

Thank you for choosing this sliding gate opener. Please read the manual carefully before assembling and using it. Do not leave out the manual if you send this product to a third party. This product complies with the recognised technical standards and safety regulations. Our company has the right to change this manual without prior notice.







## **General Safety:**

**Warning:** Incorrect or improper use of this product can cause damage to persons, animals or properties.

- Please ensure that the input voltage used matches with the supply voltage of gate opener (AC240V 50Hz).
- All modifications to wiring or electrics, and any adjustment or maintenance to 240VAC **MUST** be done by a qualified electrician.
- To avoid damaging gas, power or other underground utility lines, contact the relevant authority **BEFORE** digging.
- All potential hazards and exposed pinch points of the gate must be eliminated or guarded prior to installation of this gate motor.
- Never mount any device that operates the gate motor where the user can reach over, under, around or through the gate to operate the controls. These must be placed at least 1.8m from any moving part of the moving gate.
- Ensure power plug is disconnected from the power socket during installation or maintenance.
- Keep remote control and other control devices out of children's reach, in order to avoid unintentional activation.
- Never allow anyone to hang onto the gate while moving.
- Please ensure a warning sign provided is fitted to the structure.
- To ensure safety, before installing the main motor, mount a Gate End Stop (GTR017) and a Gate Stopper (GTR017 or GTR018) at each end of the rail to prevent the gate travelling off the track.
- If required, install infrared photocells (GTR096, sold separately) to detect obstructions and prevent injury or damage.
- Instruct all users about the control systems provided and the manual opening operation in case of emergency.
- Ensure that the power cable is connected to a RCD protected weatherproof power outlet installed by a qualified electrician.
- Do not install the product in an explosive atmosphere or where there is any danger of flooding.
- This product was exclusively designed and manufactured for the use specified in the present documentation. Any other use not specified in this documentation could damage the product and be dangerous.
- Only use original parts for any maintenance or repair operation. Richmond Wheel & Castor Co declines all responsibility with respect to the automation safety and correct operation when other supplier's components are used.
- Do not modify the automation components, unless explicitly authorised by Richmond Wheel & Castor Co.
- The user must avoid any attempt to carry out any works or repairs on the motor, and should always request the assistance of qualified personnel.
- This motor is suitable for use on one sliding gate only.
- Anything which is not expressly provided for in these instructions is not allowed and will void warranty.
- Dispose of all packing materials (plastic, cardboard, polystyrene etc.) according to current guidelines. Keep plastic bags and polystyrene out of children's reach.

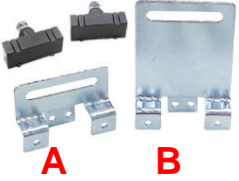
**Please save these instructions for future use.**

## Parts List:

No.	Picture	Name	Quantity
1		Main motor	1
2		Motor Mounting Plate	1
3		Manual release keys (These keys are needed during power outage, keep on hand)	2
4		Remote controls (factory paired to motor)	2
5		Gate Warning Signage (must be fitted to gate)	1
6		In the accessories box you will find the items below:	1
6a		Magnetic limit travel stops and mounting brackets (one for opening, and one for closing)	1 small bracket (A) and 1 large bracket (B), and 2 magnets
6b		Limit switch mounting plate screws M6X18	4
6c		M12 x 100mm masonry anchor bolts (Drill bit size: M12 masonry)	4
6d		Motor mounting set screws M8 x 50mm, spring & flat washers	4

## Technical Specifications:

Model	<b>GTR064</b>
Power supply	240V/50Hz
Motor power	170W
Gate moving speed	16-18m/min
Maximum weight of gate	1000 Kg
Remote control distance	Up to 30m
Remote control mode	Single button mode
Limit switch	Magnetic limit switch
Noise	Up to 58dB
Working duty	S2, 20min (20 minutes continuous operation)
IP Rating	IP54
Maximum Remote Controls to be paired	25
Frequency	433.92 MHz
Working temperature	-20°C ~ +70°C
Package weight	12.5Kg

### 1. Open/Close

Press the button for standard gate opening and closing operation.



### 4. Pedestrian Mode

Press the button while the gate is closed, the gate will open 1m wide to allow pedestrian access. Press the remote again to close.

## Motor Installation:

### Before you start

- The GTR064 Sliding Gate Automatic kit is suitable for powering the opening and closing motion of gates up to 1000kg in weight, and up to a length of 8m.
- Gate motion is achieved by the rotating cog of the gate motor driving the gear rack fitted to the moving gate (sold separately).
- The gate motor requires you to press the remote control once to open, and once again to close. This is a safety feature to ensure safe operation.
- The gate motor itself must be fitted within private property, never externally to a property's boundary.
- This premium motor has a range of optional accessories which can be added, such as solar power, battery backup, infrared photocells, exit wands, and warning light.

Power Supply: The GTR064 requires 1 x 10Amp AC240V 50Hz power supply (RCD Protected Weatherproof PowerPoint). The GTR064 comes complete with a power lead and plug that is 1m long. If you do not have a suitable RCD protected weatherproof power point within 1m of the gate motor you will need to consult a licenced electrician .

***Any works done to the motor must be completed whilst the power is off and the motor is unplugged.***

***Any modifications/alterations/works to the 240V AC power components must only be completed by a licensed electrician for your state/country.***

### **Please Note:**

Your weatherproof power outlet should be no more than 1m from the electric gate motor.

If your weatherproof power outlet is more than 1m from the gate motor, you will require a licensed electrician to fit a new power cable.

Any excess cable length should be cable tied and secured out of the way of moving objects.



## For Installing Your Gate Motor, You Will Need:

- Power drill
- Tape measure
- Level
- 12mm Masonry Drill Bit (for the 4 motor masonry anchor bolts)
- Socket and Spanner Set
- Phillips Head Screwdriver

## Example Sliding Gate Setup:

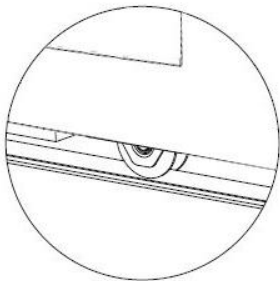
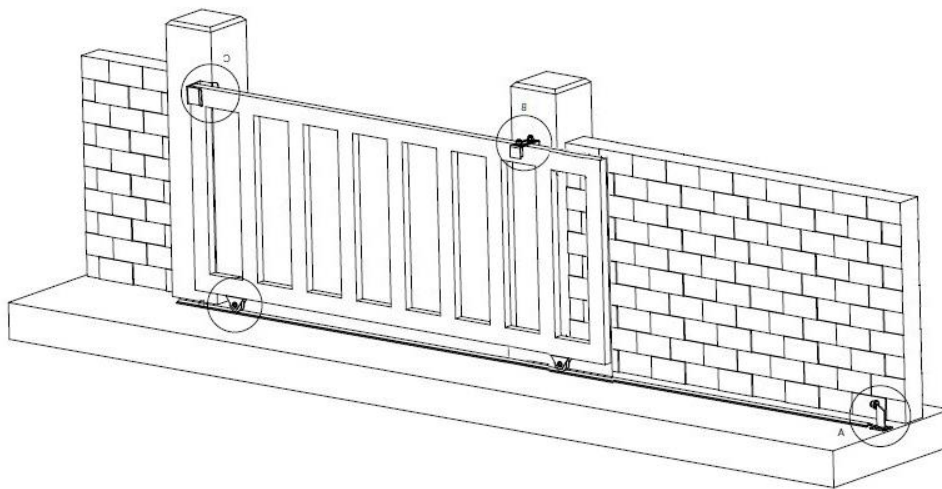

**Gate Track and  
Track Wheels**

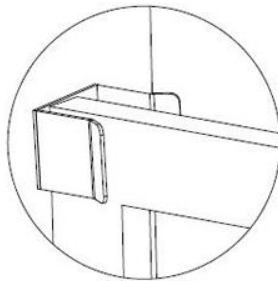

**Gate End  
Catch**

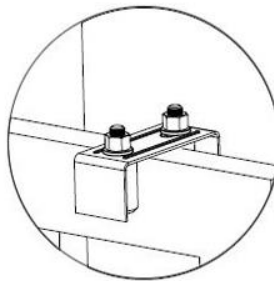

**Gate Guide  
Rollers**

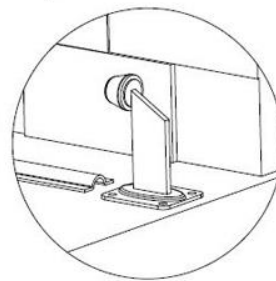

**Gate  
Stopper**

If you require any gate hardware, contact Richmond Wheel & Castor Co or an authorised reseller.

**Please ensure that the motor power cable is not plugged in at any stage before Step 8**

## **Step 1 - Gate Preparation Before Adding Your Sliding Gate Motor:**

- Ensure that the sliding gate is correctly installed.
- The gate is horizontal and level and the gate can glide back and forth smoothly when moved by hand before installing the Automatic Gate Opener.
- Wheels and guide rollers should rotate easily and be free from dirt/grime.
- Track should be flat, level and firmly affixed.
- Any misalignment in the gate will affect performance of the automatic gate opener.

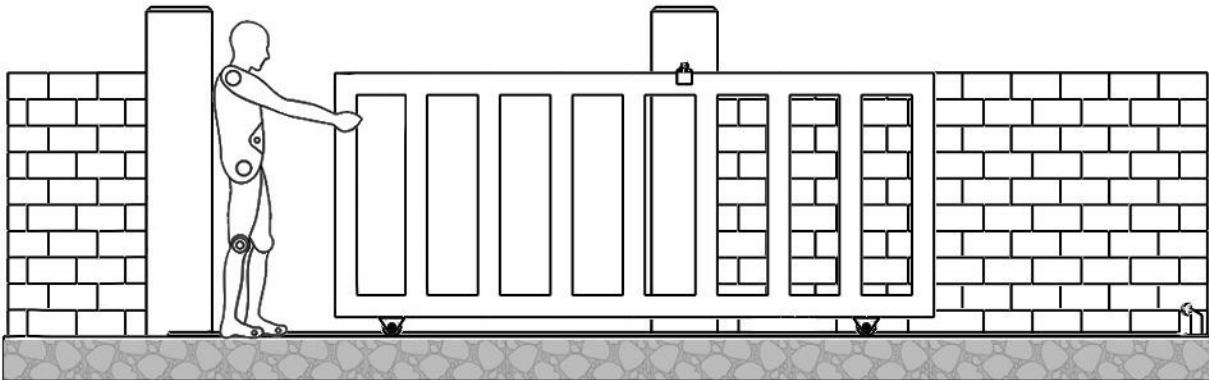

The gate should slide smoothly by hand before attempting to install the gate opener.

## **Step 2 - Motor Pad Footing (If Required):**

- The motor pad footing requires an area of no less than 450mm long x 300mm wide and a minimum depth of 200mm (Standard requirement).
- Ensure surface is level and parallel to the driveway

### **Mounting Plate Dimensions:**

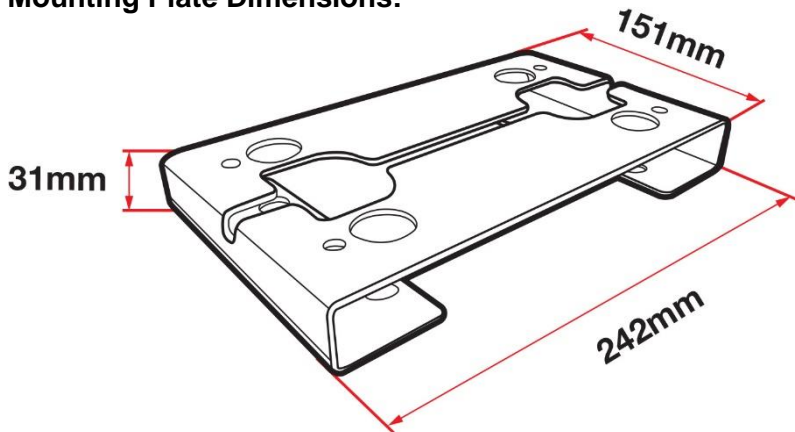

### Step 3 - Motor Position installation:

- Insert the key and open the manual release bar to put the motor into manual mode, and check that the motor cog rotates freely by hand (As per Fig 15).
- Place the motor and motor mounting plate on the concrete pad.
- Make sure the distance between the gate motor cog and gear rack position are aligned.
- Mark all four corners of the mounting plate on the concrete pad using a pencil, chalk or similar, to ensure the mounting plate is in the correct position before drilling.
- Remove motor from the mounting plate.

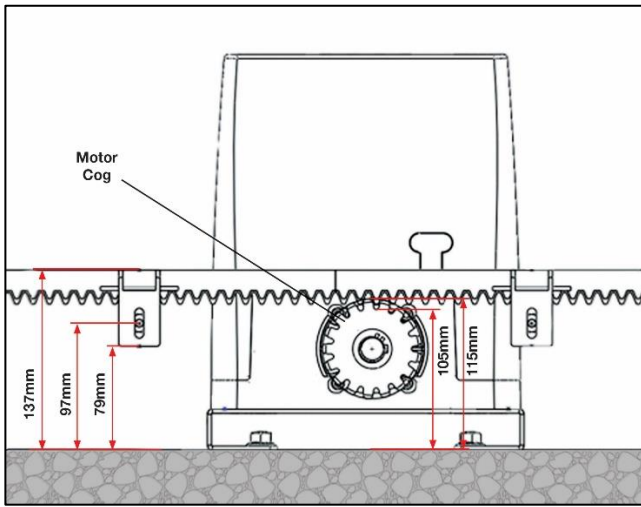

Fig 3

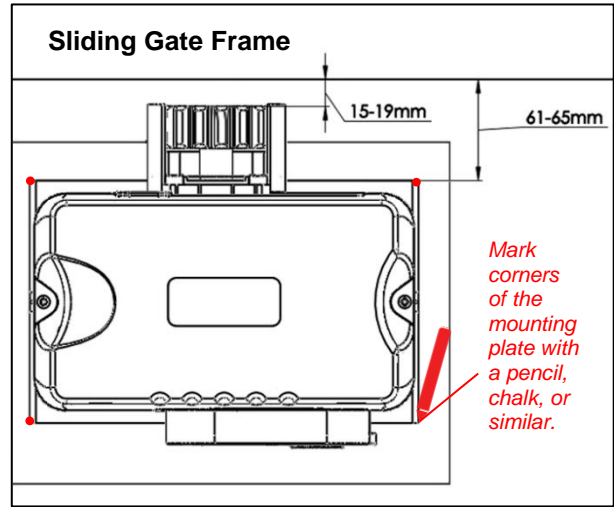

Fig 4

### Step 4 - Drilling holes for anchor bolts:

- Mark the (4) positions for your anchor bolts ready for drilling (refer to Fig 5).
- Remove Mounting plate.
- Using a M12 masonry drill bit, drill holes to a minimum depth of 120mm (Fig 6).

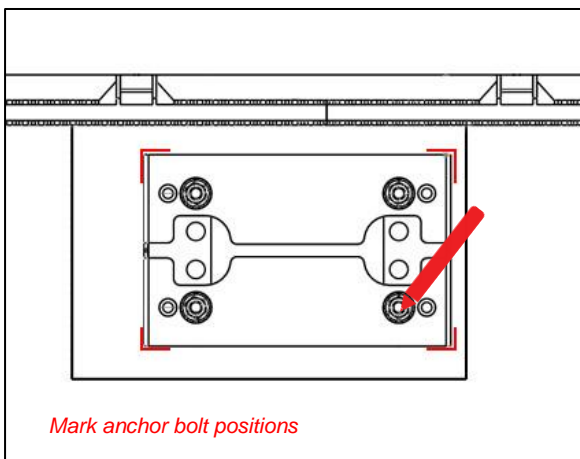

Fig 5

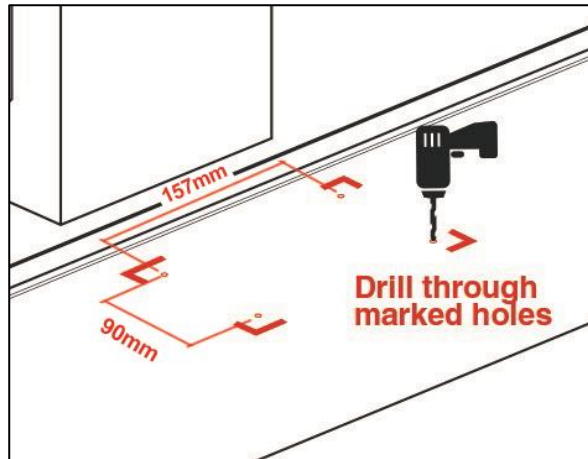

Fig 6

## Step 5 - Fitting mounting Plate & Motor:

- Fit motor mounting plate back into place and fit and tighten anchor bolts (as per figures 7 and 8).
- Fit motor back on mounting plate, ensuring the power cord is positioned into the end slot of the mounting plate in the direction of the power point, making sure there are no pinch points (as per fig 9).
- Slide rubber grommet along the power lead and into the end slot of the mounting plate (as per figures 10 & 11).
- Bolt motor to the mounting plate using the M8 x 50mm bolts with spring and flat washers provided and tighten as required (as per figure 12).

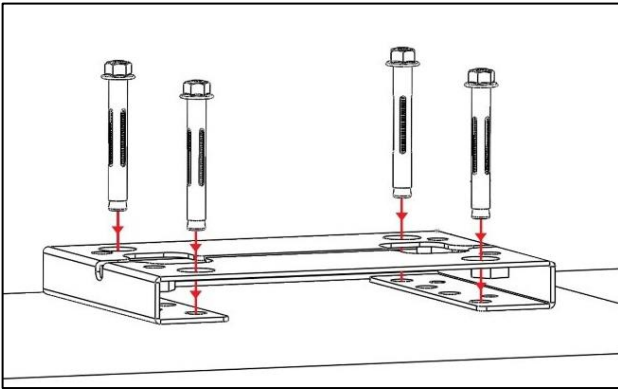

Fig 7

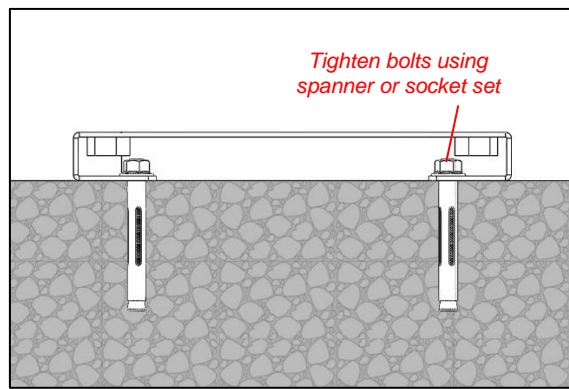

Fig 8



Fig 9



Fig 10



Fig 11

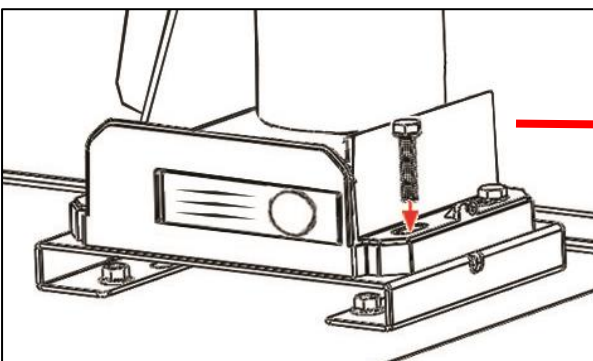

Fig 12

Insert the M8 x 50mm bolts (Part 6d), spring washers, and flat washers provided through motor housing and screw into welded nut on the baseplate.

Hand-tighten set screws before final adjustment of motor.



Please ensure that the motor power cable is not plugged in at any stage before Step 8

### Step 6 - Gear Rack & Motor Alignment:

- Insert the key and open the manual release bar to put the motor into manual mode, and check that the motor cog rotates freely by hand (as per fig 15).
- Ensure that the gate drive cog has a minimum clearance of 1-2mm along the entire length of gear rack fitted to the gate (as per Fig 13)
- Ensure cog and rack are correctly aligned. Under no circumstances should the gate motor drive cog carry any weight of the gate. It is the task of the gate castors or wheels to carry the weight of the gate. (As per Fig 14)
- If the gate doesn't slide freely by hand, adjust gear racks height accordingly until the full length of gate slides freely by hand.

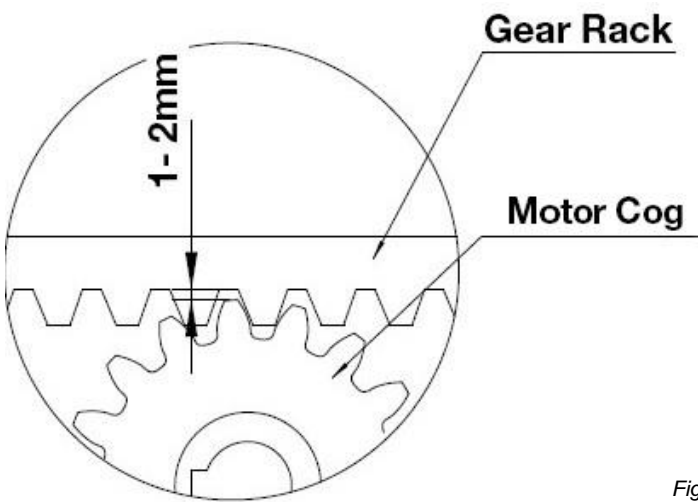
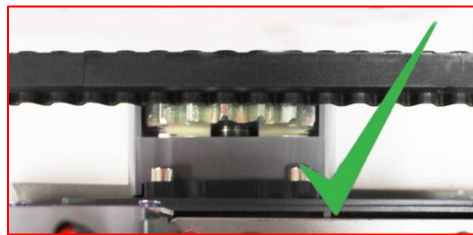

Fig 13



Gear rack correctly aligned at 90° to the motor cog



Fig 14

Gear rack misaligned. Do not attempt to use if misaligned.

At this stage of final assembly, the cover is removed (not shown) and the power cable is still unplugged.

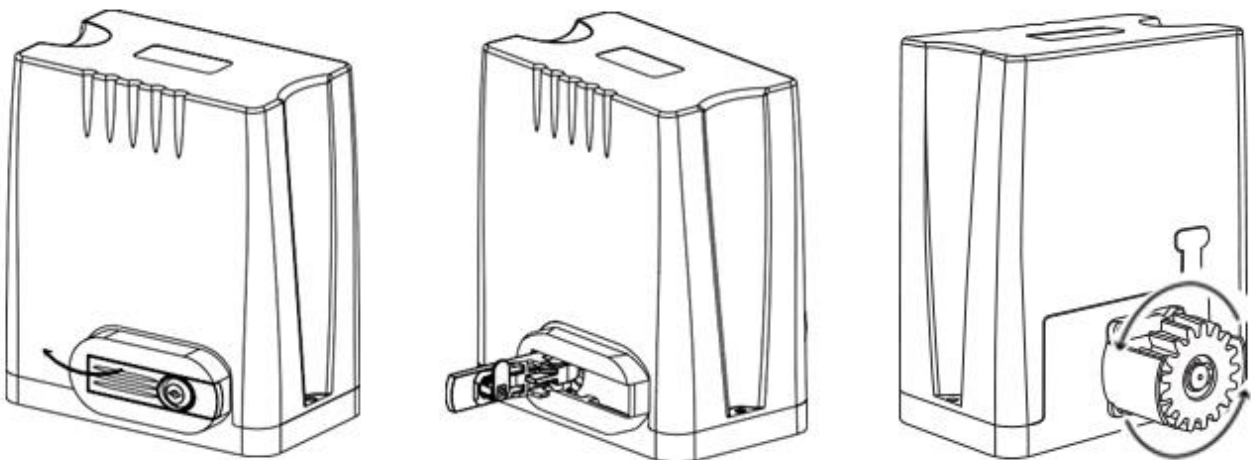

Fig 15

To put the gate motor into manual mode, insert the key and open the manual release bar as shown. In manual mode, the gear can turn freely, and the gate can be operated by hand.

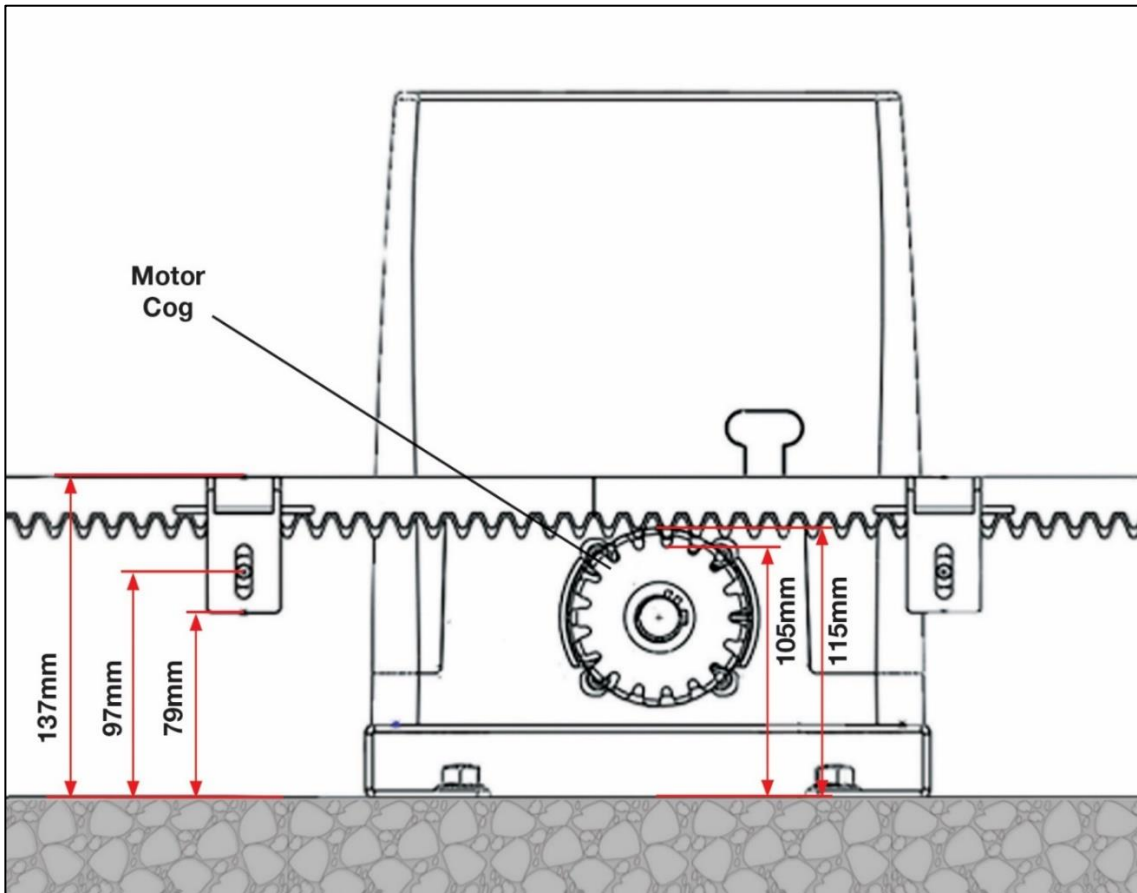

Fig 16



Fig 17

**Please Note:**

The warning signage provided (Part 5) must be displayed on the frame of your automatic gate at all times.

## Step 7 - Magnetic limit switch stops Installation:

Included in your gate motor kit are two magnetic limit travel stops which must be fitted to the gear rack on your gate to ensure safe operation.

The magnetic limit travel stops are designed to set the desired opening and closing position of your gate.

These limit travel stops activate when the magnets travel past a magnetic limit switch sensor under the motor cover (refer to Fig 19 & 20). See page 32 for an image of the magnetic limit switch sensor.

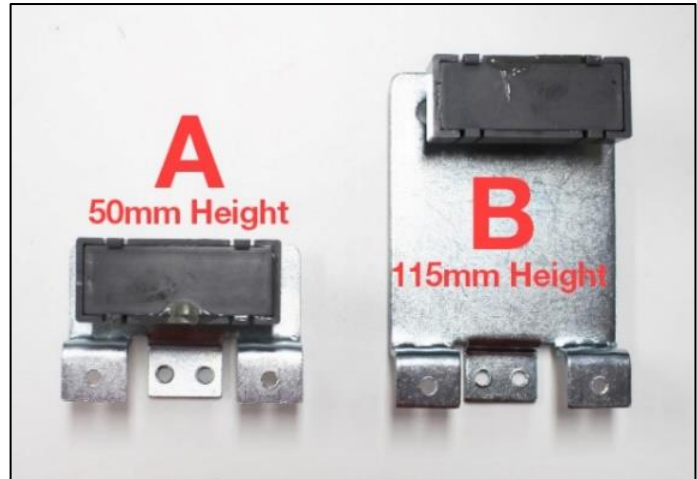

Fig 18

**Please note: gates can open and close in different positions due to different weights of gates, terrains, slopes (uphill or downhill). The distance the gate will travel after triggering the magnetic limit switch may vary.**

## Setting the limit travel stops:

### Closed Position

- Position gate 150-200mm back from the gate end catch closed position. This will help in making sure you do not slam the gate into the gate end catch.
- Position Magnetic Limit Travel Stop B (**LARGER**) central to the magnetic limit switch sensor on the motor (as per fig 19).
- Tighten locking screws provided.

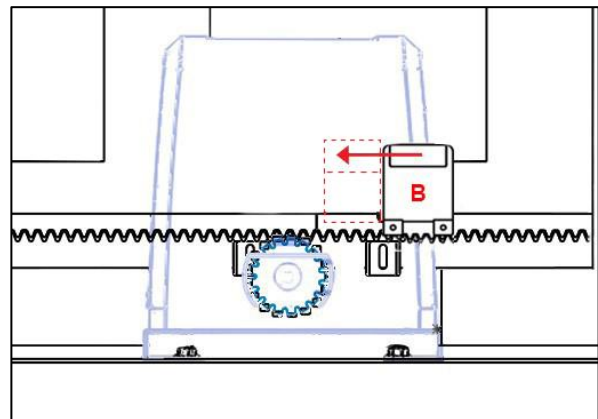

Fig 19

### Open Position

- Position gate 150-200mm back from the gate stopper open position.
- This will help in making sure you do not slam the gate into the gate stopper.
- Position Magnetic Limit Travel Stop A (**SMALLER**) central to the magnetic limit switch sensor on the motor (as per fig 20).
- Tighten locking screws provided.

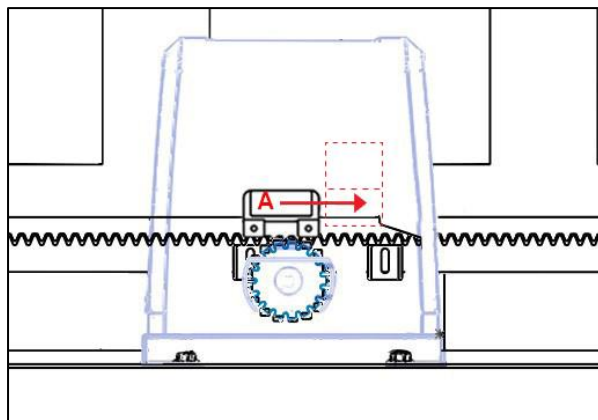

Fig 20

**To Reset:** When setting new limit stop positions please ensure that you turn the power off and then on again. Turning the power off will reset the limit travel stop memory, allowing for new limit travel stop positions to be recognised by the motor.

Refer to **Step 9** for testing and adjusting the limit travel stops.

**Note: The default setting is right side open.**

Magnetic Limit Travel Stop B (LARGER) should be positioned at the closed position.

Magnetic Limit Travel Stop A (SMALLER) should be positioned at the open position.

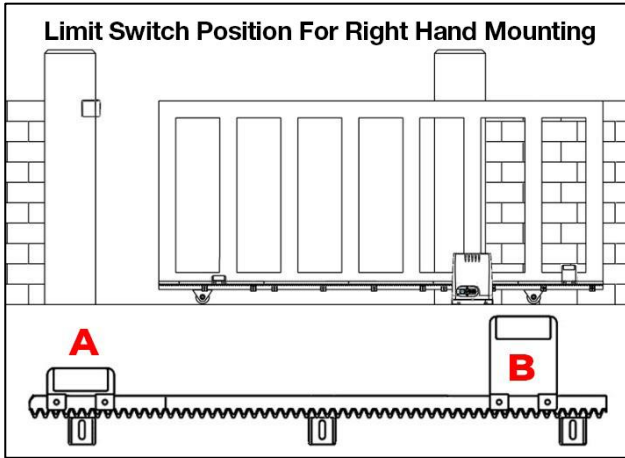

Fig 21

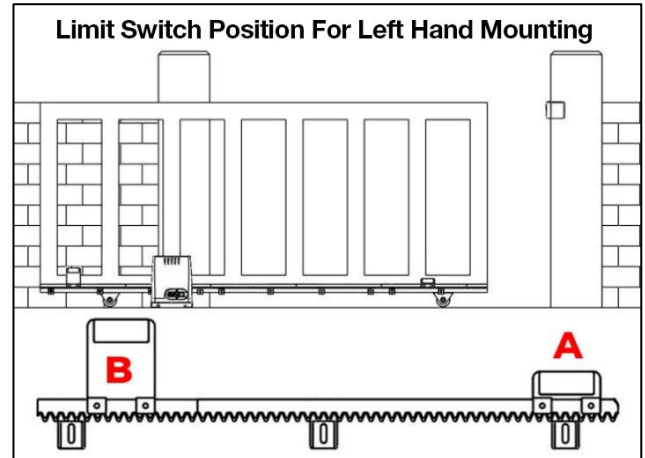

Fig 22



Fig 23

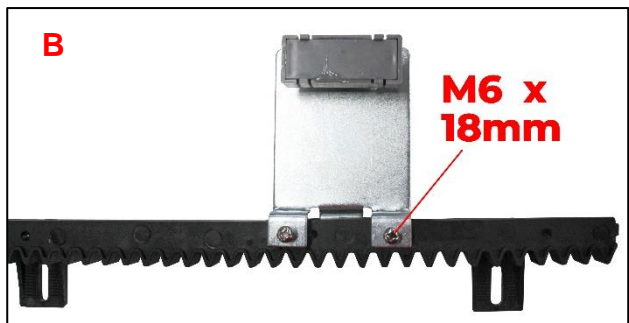
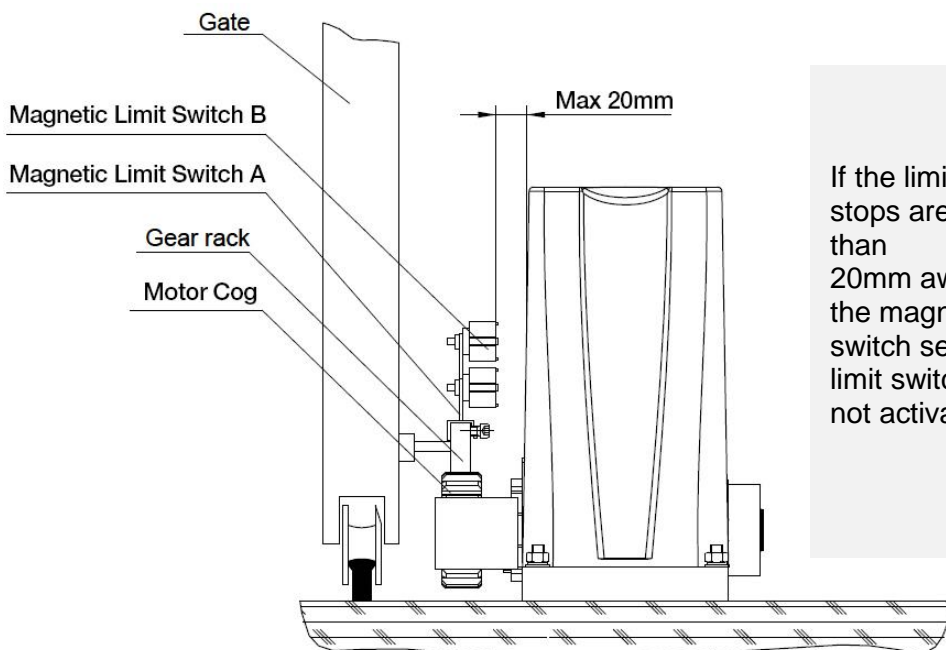

Fig 24



If the limit travel stops are more than 20mm away from the magnetic limit switch sensor the limit switch may not activate.

Fig 25



## Step 8 - Powering the Motor:

- Ensure that the outer cover has been fitted and fastened back onto the motor housing.
- Before powering up the motor make sure the gate can travel by hand in manual mode (key unlocked).
- Slide the gate to between the middle of the posts, approximately.
- Lock the key (key locked) in readiness for automatic mode.
- Plug the power cord into an approved RCD protected weatherproof outlet.
- Remote controls (Part 4) included in this kit are factory paired ready for use.

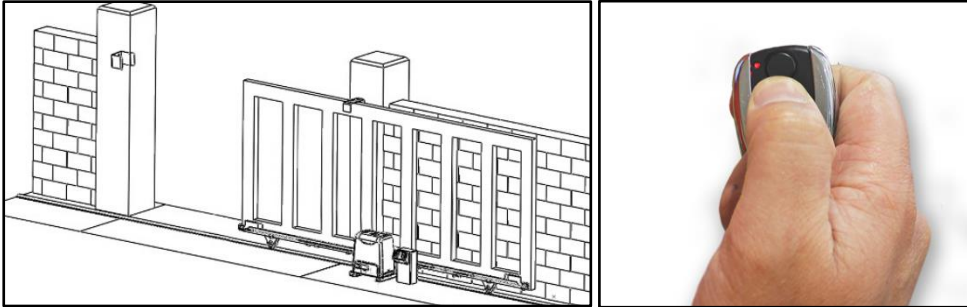

### Note:

- The default setting is opening to the right. 
- Press the remote control and the gate will open until the magnetic limit travel stop passes the magnetic limit switch sensor. Press the remote control again and the gate will close.
- Soft start/soft stop function - The GTR064 is set by default to provide the soft start/soft stop function. We recommend this default position is always maintained.

**Your motor is now set up for basic remote-control operation. To set further functions and settings, see pages 19-32**

## Step 9 – Testing and Adjusting the Magnetic Limit Travel Stops:

### Testing the closed position

- Ensure motor is plugged in as per step 8 and the gate is in the open position.
- Press remote (remotes included in kit are factory paired to the motor). The gate will begin to close.
- The gate will stop when the magnetic limit travel stop reaches the magnetic limit switch sensor during closing (refer to figs 19 and 20).
- When the gate stops, measure the distance remaining between the gate and the desired closed position.
- You have now determined the closed position of the gate when the travel limit stop passes the magnetic limit switch sensor.
- Adjust the magnetic limit travel stop from the measurement you have taken to get your desired closed position. The ideal closed final position for the gate frame is 10-15mm from the closed gate end catch (GTR019).

### Testing the open position

- Press remote. The gate will begin to open.
- The gate will stop when the magnetic limit travel stop reaches the magnetic limit switch sensor during opening (refer to figs 19 and 20).
- When the gate stops, measure the distance remaining between the gate and the desired open position.
- You have now determined the open position of the gate when the travel limit stop passes the magnetic limit switch sensor.
- Adjust the magnetic limit travel stop from the measurement you have taken to get your desired open position. The ideal open final position for the gate frame is 10-15mm from the gate stopper (GTR017).

### To Reset:

When setting new limit stop positions please ensure that you turn the power off for at least 15 seconds and then on again. Turning the power off will reset the limit stop memory, allowing for new limit travel stop positions to be recognised by the motor.

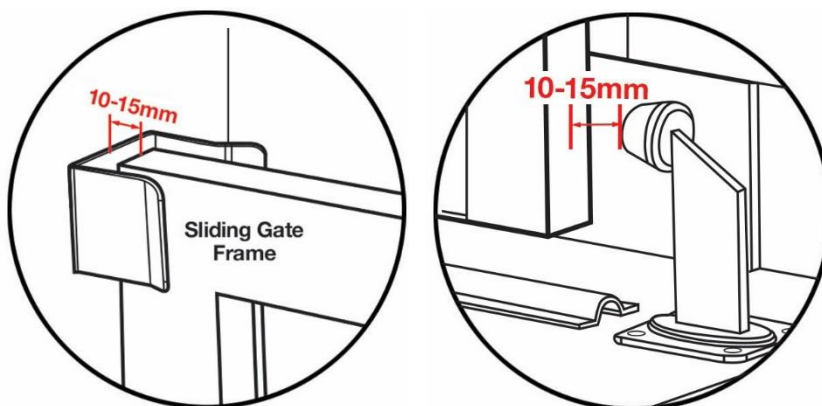

Fig 26

# Programming and Wiring: Control board wiring diagram 01

*Ensure power is off before any modifications are made.*

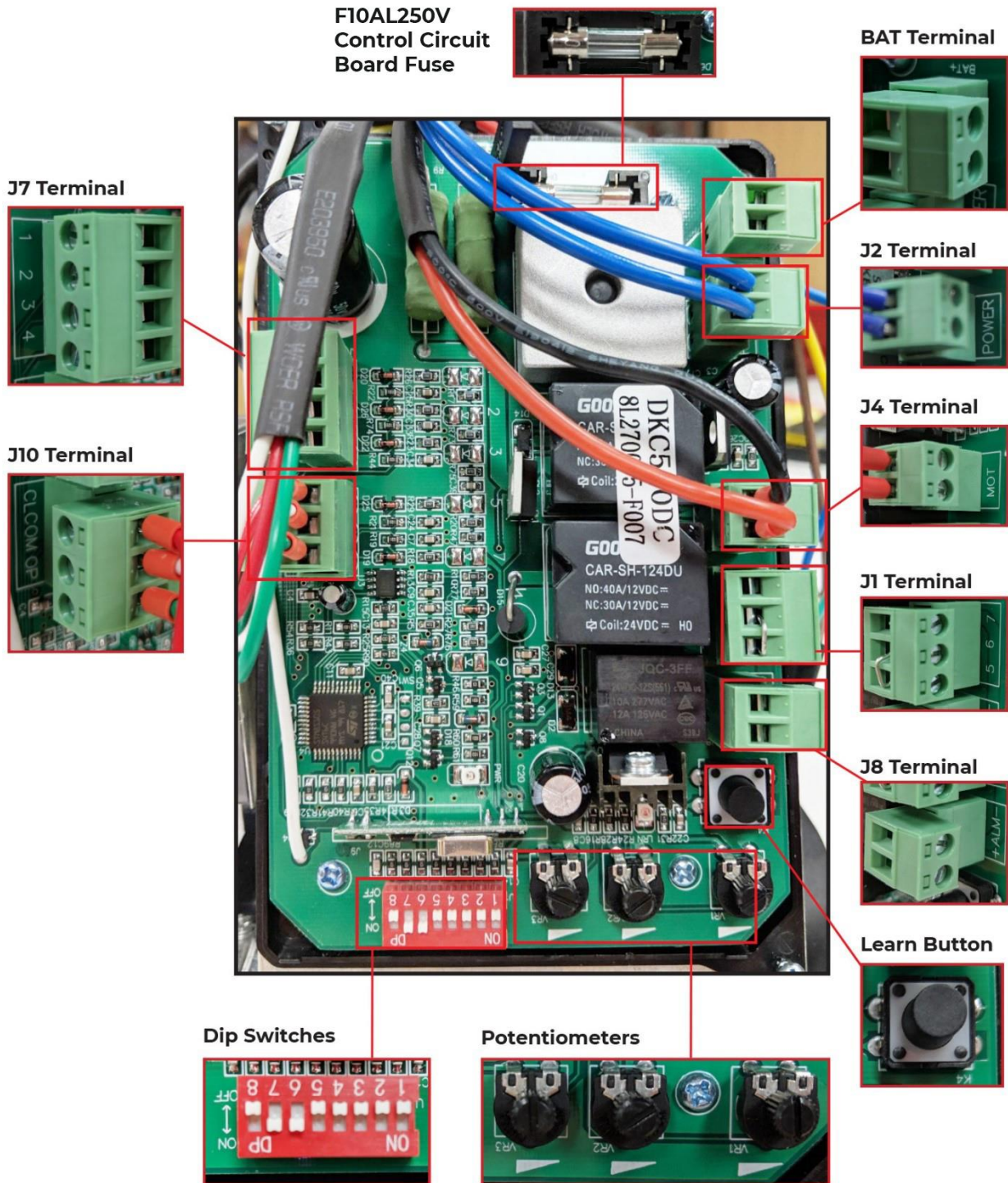

Fig 27

# Programming and Wiring: Control board wiring diagram 02

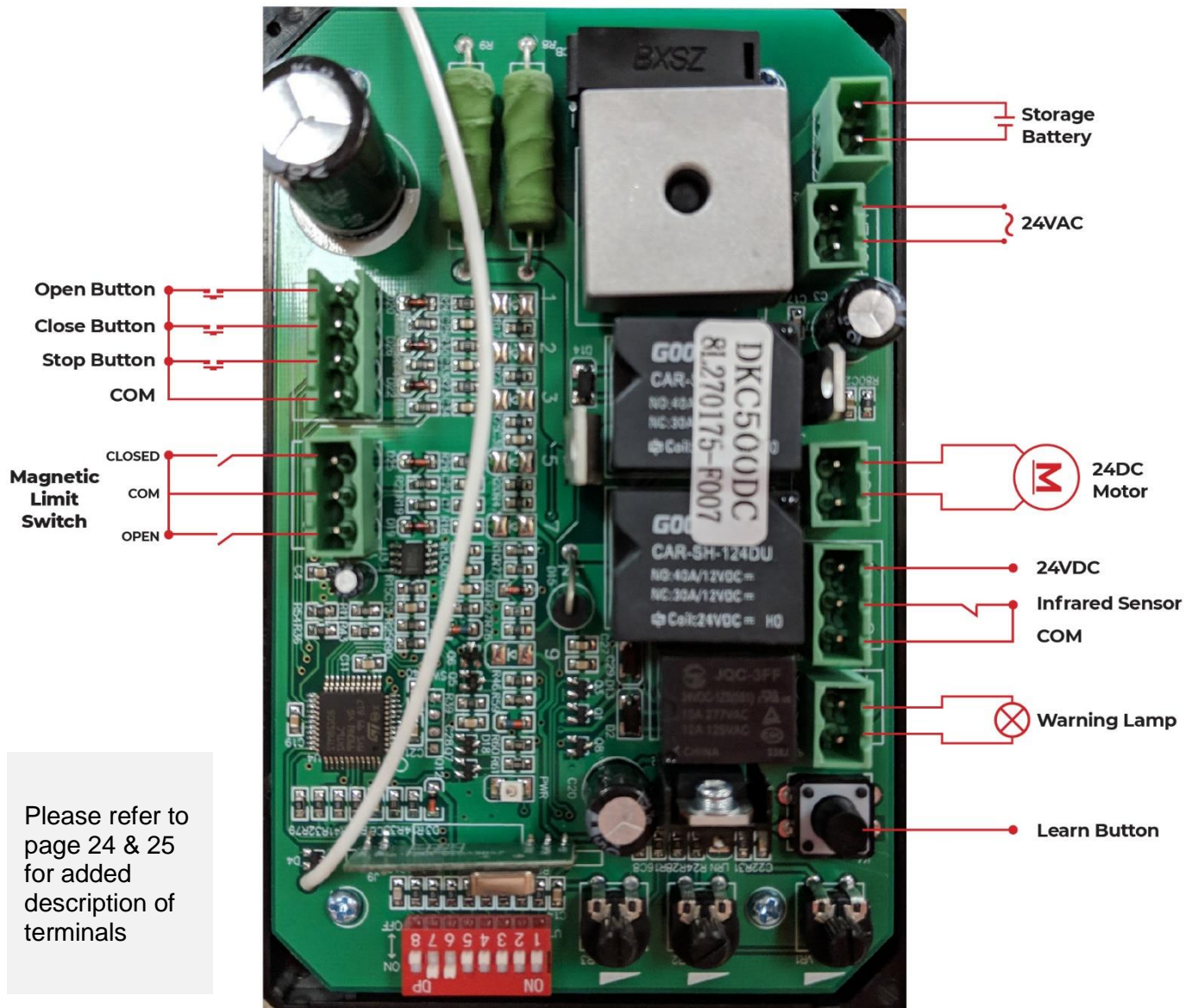

Fig 28

## Transformer Power Input Connection:

**WARNING:** Do not touch 240VAC. All works to mains power must be conducted by a licensed electrician.

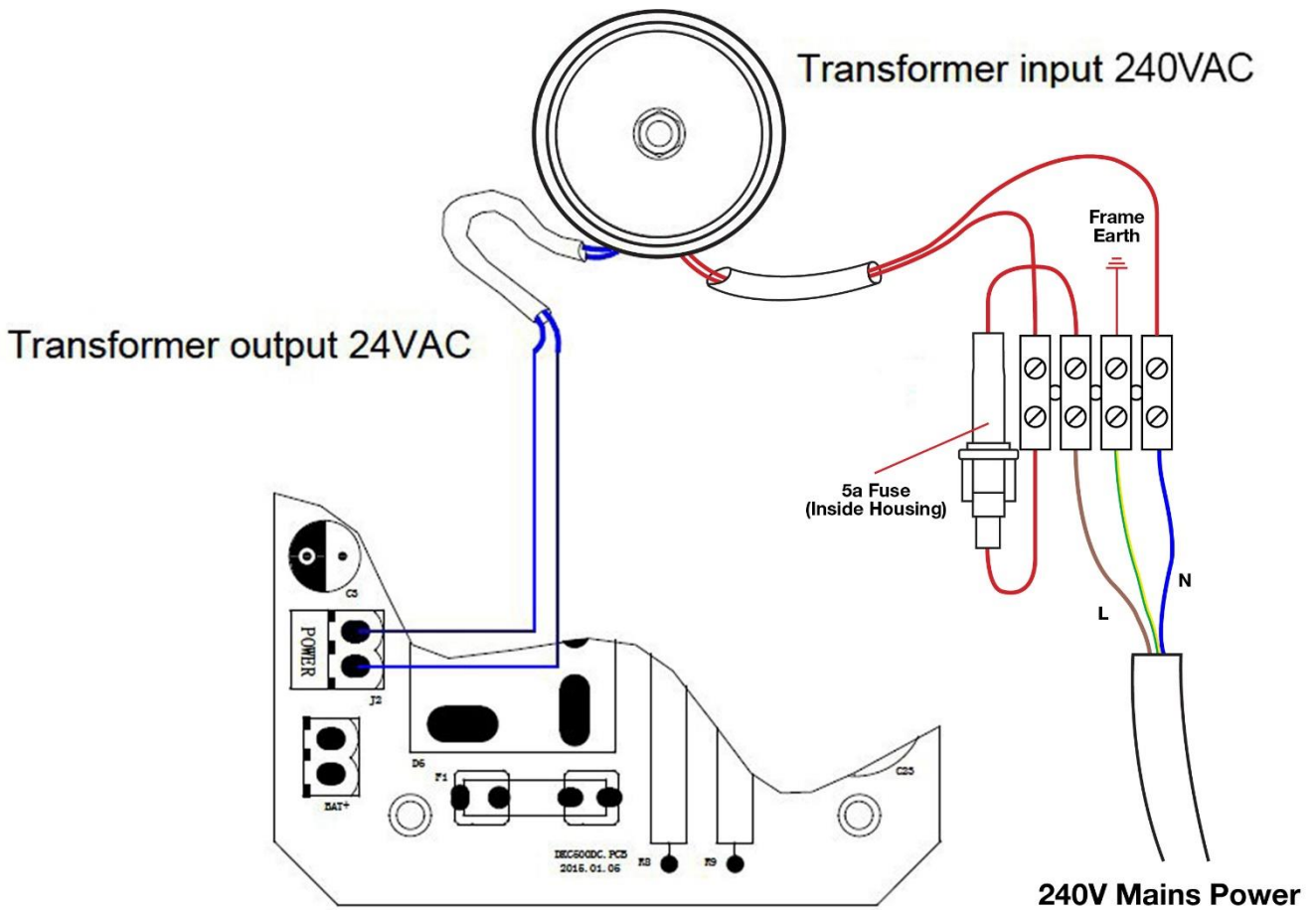
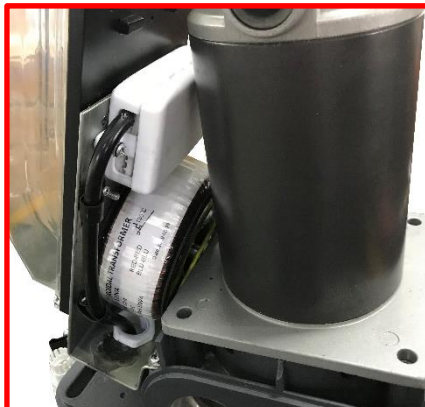

Fig 29



**Live parts  
behind cover**

**DO NOT TOUCH**  
All works to mains power  
must be conducted by a  
licensed electrician.

## Dip Switch Adjustment:

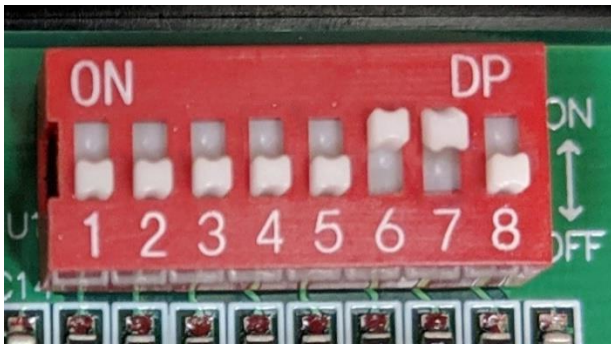

Number	Description
1	<b>Automatic Close Function</b> 1 ON 2 OFF: automatic close delay time is 3s. 1 OFF 2 ON: automatic close delay time is 10s. 1 ON 2 ON: automatic close delay time is 30s. 1 OFF 2 OFF: no automatic close function.
2	Default position is 1 OFF 2 OFF
3	<b>Remote Control Mode</b> leave in OFF position unless an additional module is used. Default position is OFF
4	<b>External Button Mode</b> Leave in OFF position unless an additional module is used. Default position is OFF 4 OFF: Hard wire keypad
5	<b>Left/Right Open Setting</b> OFF – Right hand open ON – Left hand open Gate close direction will be changed after motor is restarted Default position is OFF (right hand)  Swap over CL & OP limit switch lines on terminal J10 (refer to page 24)
6	<b>Magnetic Limit Switch</b> Leave in the ON position, OFF - Normal close ON - Normal open Default position is ON Magnetic limit switch, Normally Open/Normally Closed, usually the magnetic limit switch is Normally Open.
7	<b>Stall Force</b> ON - Enabled OFF - Disabled Default position is ON
8	<b>Infrared Detection Delay When Closing</b> ON – Infrared detection delay is set to 1 second OFF – Infrared detection delay is disabled Default position is OFF

## Further Settings & Programming:

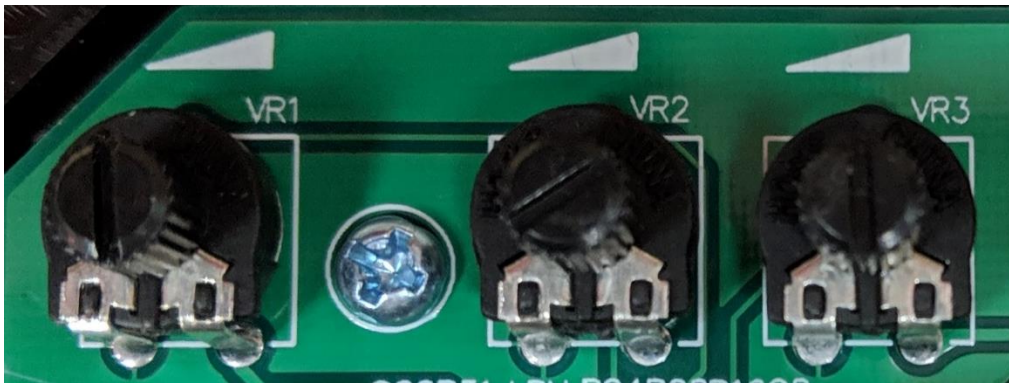

### **VR1: Total Working Time Adjustment**

Rotate clockwise to increase, counter-clockwise to decrease. Total time can be set to 10 seconds minimum, and 90 seconds maximum.

The default setting is at maximum.

### **VR2: Unused**

### **VR3: Stall Force Adjustment**

Rotate clockwise to increase, counter-clockwise to decrease.

The default setting is at maximum.

When stall force is enabled (DIP switch 7 is at the ON position), the motor will detect obstacles and impacts to the gate. If this is during opening, the gate will stop, if this is during closing the gate will stop, and then re-open.

**Note: If the stall force is too low**, the gate will stop or reverse very easily while there is no obstruction, or if there is additional resistance such as strong wind, rain or snow. **If the stall force is set too high**, some impacts may not be detected, and injury or damage could occur.

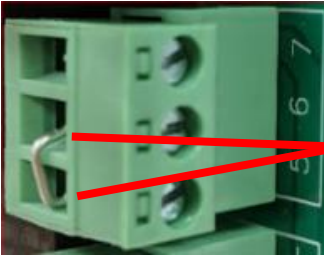

### J1 Terminal:

**Terminal 5:** Common (Ground).

**Terminal 6:** Photocell input (Normally Closed). If no photocell is fitted use jumper between terminals 5 & 6.

**Terminal 7:** Extra power input +24VDC.



### J7 Terminal:

**Terminal 1:** Optional External Open Push Button Switch.

(Hard Wired keypad connection between terminals 1 & 4)

**Terminal 2:** Optional External Close Push Button Switch.

**Terminal 3:** Optional External Stop Push Button Switch.

**Terminal 4:** Common Terminal for All Optional Push Buttons.



### J10 Terminal:

**Factory Fitted (pre-wired)**

**CL:** Close Magnetic Limit Switch.

**COM:** Limit Switch Common Terminal.

**OP:** Open Magnetic Limit Switch.

**Please note:** the CL & OP wires will need to be swapped over if the gate direction is changed

## Connecting Wires to the Terminal:



Using a screwdriver, loosen the screw on the side of the terminal.

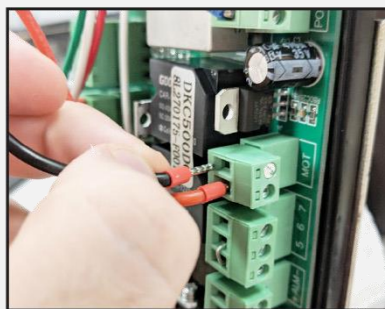

Insert the wire into the number on the terminal that you are looking to connect to. Refer to Pages 18 & 19



Tighten with a screwdriver to secure the wire in place.



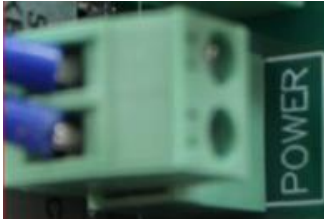

### **J2 Terminal:**

**Factory Fitted (pre-wired)**

Connect to 24VAC power from transformer.



### **BAT Terminal:**

Battery Backup Terminal.



### **J4 Terminal:**

**Factory Fitted (pre-wired)**

DC motor wire connection (Red wire to top,black wire to bottom).



### **J8 Terminal:**

24V DC warning light connection.

## Connecting Infrared Photocells:

Richmond highly recommend the use of infrared photocells as an additional safety feature. While closing, if infrared beam of the photocell is blocked, the gate will stop and reverse immediately, to protect user and property security.

To install photocells, connect wiring as per Figure 30. You must remove the wire jumper between 5 and 6 on the J1 terminal.

Infrared receiver connecting

Infrared emitter connecting

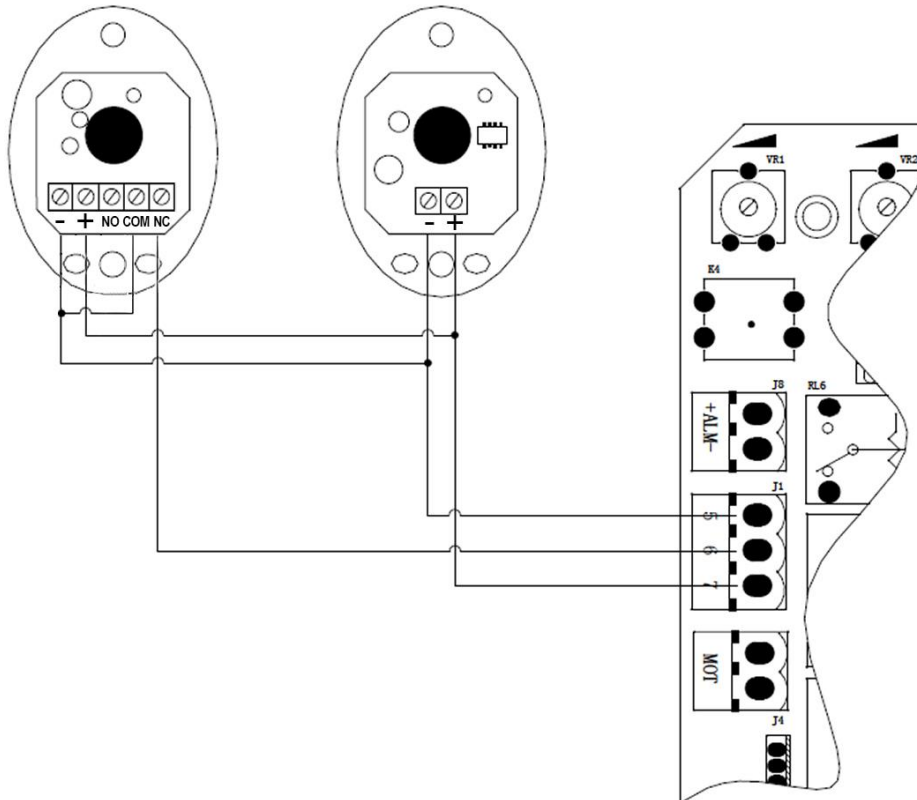

Fig 26

## Before Installing Photocells



Loosen J1 Terminals 5 and 6 with a screwdriver. Make sure the power is disconnected before doing so.



Remove the wire jumper between J1 Terminals 5 and 6

## Battery/Solar Connection

Battery backup can be useful in areas where mains power may be intermittent. Depending on the size and setup of your gate, batteries may be able to operate the gate up to ten times without being recharged.

Solar power is useful in areas where mains power is not readily available. The correct solar power and battery will depend on the size and setup of your gate, position of the panels and geographical area. Under normal conditions we recommend 2 x 12V 12Ah batteries, and 1 24V 30W solar panel.

Note that performance may vary according the amount of sunlight per day, and condition of the batteries.

To install battery backup and/or solar power, refer to the Figures 11 and 12 below.

Note: For 100% Solar requirements please contact Richmond.

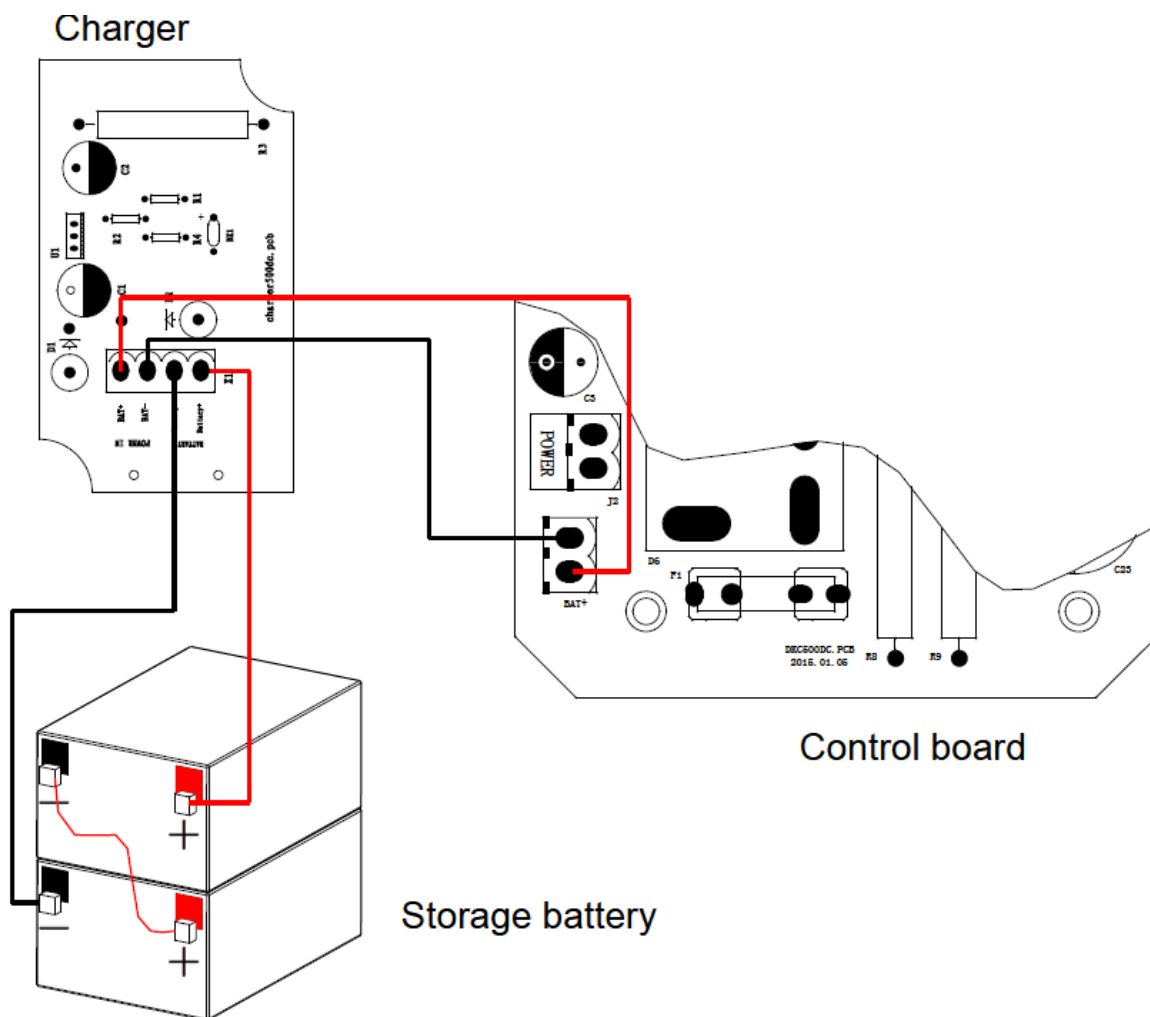

Battery Part Number:  
GTR160

Fig 27

**Battery backup charger and batteries sold separately**

# Solar Panel Connection

Solar panel

Solar charge Controller

Storage battery

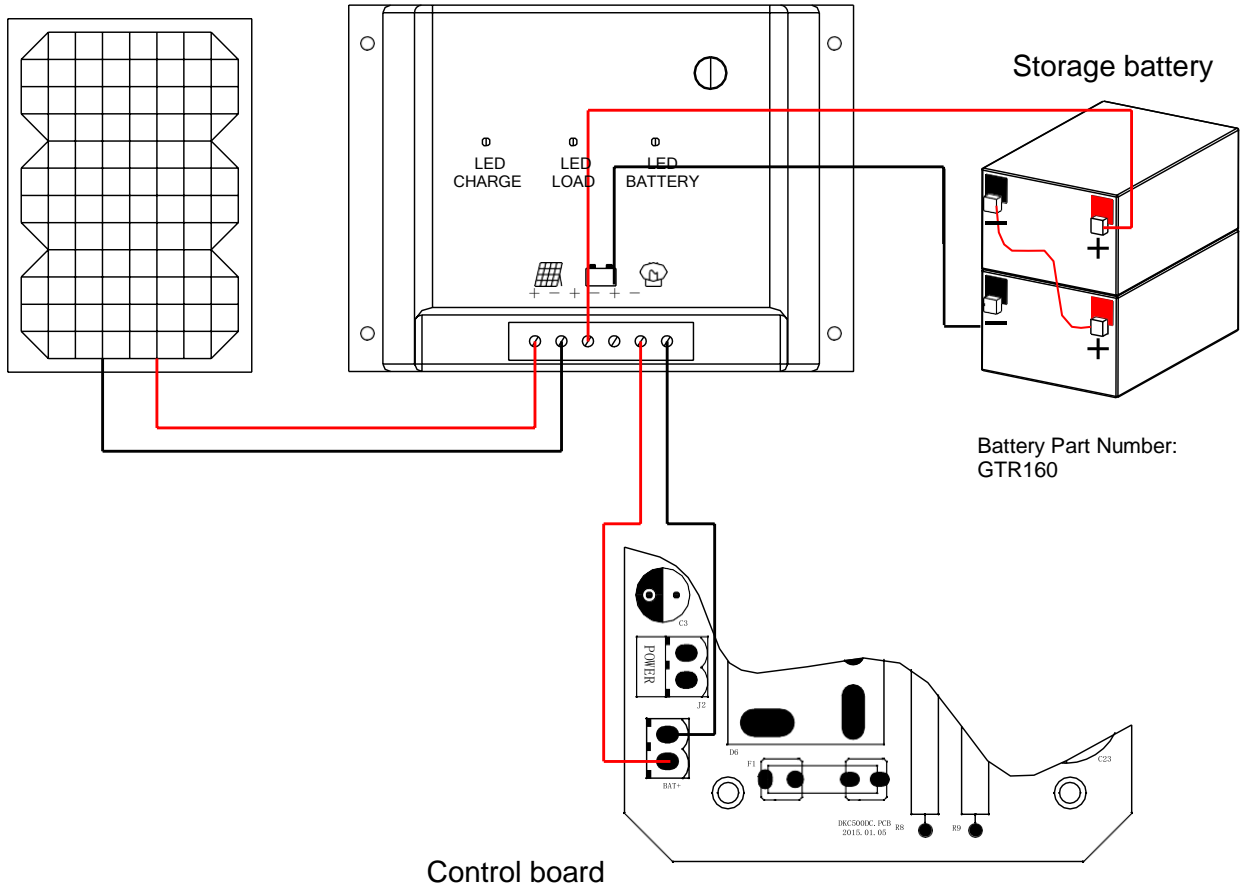

Battery Part Number:  
GTR160

Fig 28

## **Maintenance:**

Under normal operation, the gate should be checked every 6 months:

- Lubricate shafts and sprockets
- Check and tighten anchor bolts
- Check for loose and corroded wires.
- Check the earth wire (green/yellow) is firmly attached to the housing with the screw. This should be checked by a licensed electrician.
- Always check the stall force after performing any maintenance. If this function does not work, do not use the gate motor until this is rectified.

## Troubleshooting:

Any works done to the motor must be whilst the power is off and the motor is unplugged.

Problems	Possible Reasons	Solutions
The gate cannot open or close normally, and LED does not light.	<ol style="list-style-type: none"> <li>1.The power is off.</li> <li>2.Fuse is blown.</li> <li>3.Control PCB is damaged</li> </ol>	<ol style="list-style-type: none"> <li>1.Switch on the power supply.</li> <li>2. <b>Licensed electrician</b> Check the fuse (F1) and replace if necessary.</li> <li>3.Contact Richmond Wheel &amp; Castor Co for replacement PCB</li> </ol>
Remote control doesn't work.	<ol style="list-style-type: none"> <li>1. Remote control battery is flat.</li> <li>2. Remote control is not paired correctly.</li> </ol>	<ol style="list-style-type: none"> <li>1.Check LED lights up when button is pressed. If not, change the remote-control battery (A27 battery required)</li> <li>2. Repeat pairing procedure</li> </ol>
The gate opens but cannot close.	<ol style="list-style-type: none"> <li>1. Photocell beam is interrupted.</li> <li>2. Stall force is set too low</li> <li>3. Photocell settings not correct.</li> <li>4. Photocell not mounted correctly.</li> </ol>	<ol style="list-style-type: none"> <li>1. Check and remove any obstructions.</li> <li>2. Increase stall force VR3 potentiometer.</li> <li>3. If photocell is not connected, ensure the jumper wire between 5 and 6 on the J1 terminal, and dip switch 6 is set to ON. If photocell is connected, remove jumper 5 and 6 and ensure the wiring is correct and dip switch 6 is set to OFF (N.C.).</li> <li>4. Make sure photocell beams are correctly positioned.</li> </ol>
Gate does not move when button is pressed, but motor makes a noise.	<ol style="list-style-type: none"> <li>1. Gate is out of alignment.</li> </ol>	<ol style="list-style-type: none"> <li>1. Connect in manual mode and check if it can be opened by hand. If cannot be easily opened, re-set up.</li> <li>2. Contact Richmond Wheel &amp; Castor Co for replacement PCB.</li> </ol>
Gate does not stop at the limit switch magnet when opening/closing.	<ol style="list-style-type: none"> <li>1. The gate direction is incorrect.</li> <li>2. The limit switches magnets are positioned incorrectly.</li> </ol>	<ol style="list-style-type: none"> <li>1. Turn Dip switch 5 from ON or OFF (depending on its current setting)</li> <li>2. refer to Pages 15 &amp; 16.</li> </ol>
Current leakage switch tripped.	<ol style="list-style-type: none"> <li>1. Short circuit in the power supply line.</li> </ol>	<ol style="list-style-type: none"> <li>1. Licensed electrician to check wiring.</li> </ol>
Remote control working distance is too short.	<ol style="list-style-type: none"> <li>1. Signal is blocked or too much interference.</li> </ol>	<ol style="list-style-type: none"> <li>1. Connect external receiver antenna 1.5 meters above ground.</li> <li>2. check remote control battery</li> </ol>
Gate does not fully open or close	<ol style="list-style-type: none"> <li>1. Motor output force is too low.</li> <li>2. Stall force is too low.</li> <li>3. Gate meets obstacle.</li> </ol>	<ol style="list-style-type: none"> <li>1. Increase VR2 potentiometer.</li> <li>2. Increase VR3 potentiometer.</li> <li>3. Remove the obstacle.</li> </ol>

## Clearing Remote Controls:

- To delete all paired remote controls,
- Press and hold the learning button K4 for approximately 8 seconds. Once the indicator light LRN turns off, all remote controls previously paired will be deleted.

## Pairing Remote Controls:

- While the motor housing cover and clear plastic PCB cover are removed,
- Press the learning button K4 on the control board, until the indicator light LRN turns on, then release the button.
- While the light is on, press the first button on the remote control twice within 4 seconds, the LRN will flash repeatedly and then turn off when remote control is paired.



**Press and hold the learn button (S1) until the Learn LED flashes ON.**



**While the light is on, press the first button on the remote control twice.**



**The Learn LED will flash repeatedly and then turn OFF. when the remote is paired.**

## Technical Support

For support or assistance with installing your gate motor, ring your local Richmond Wheel & Castor Branch on 1300 474 246. For detailed technical support, ring our Engineering Department on 03 9551 2233.

Richmond Wheel & Castor Co declines all responsibility for any consequences resulting from improper use of the product, or use which is different from that expected and specified in the present documentation.

Richmond Wheel & Castor Co declines all responsibility for any consequences resulting from failure to observe Good Technical Practice when constructing closing structures (door, gates etc.), as well as from any deformation which might occur during use.

**Additional Drawings and Measurements:**

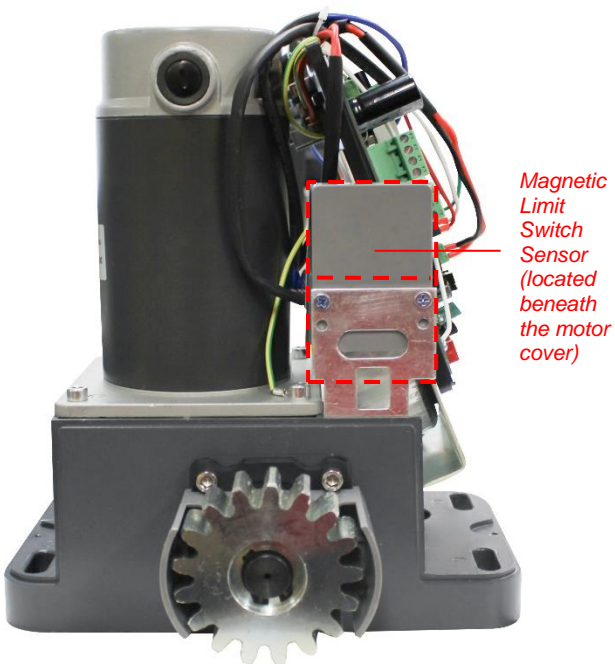
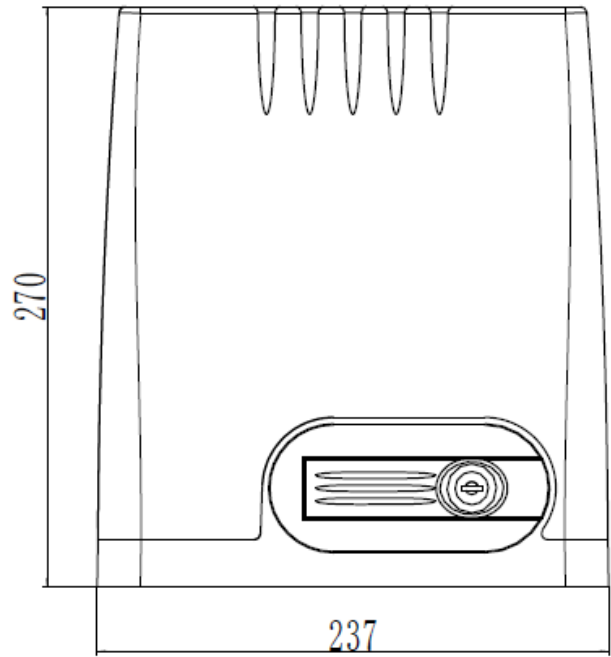
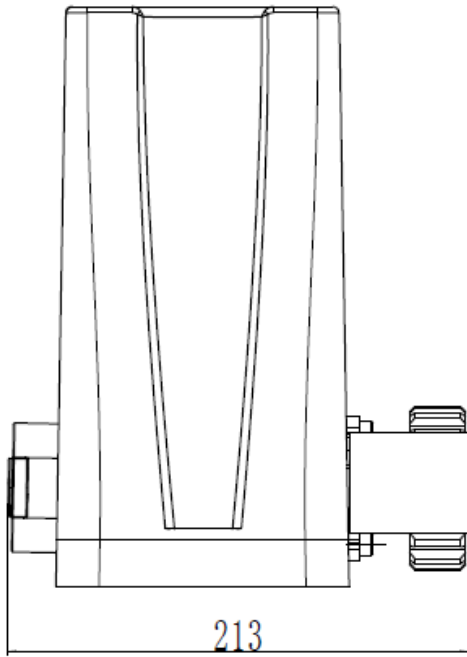

*Magnetic  
Limit  
Switch  
Sensor  
(located  
beneath  
the motor  
cover)*