



Solar Swing Gate Opener User's Manual

For Gate Kits:

GTR062 Single Solar Swing Gate Kit
GTR078 Double Solar Swing Gate Kit



- Please read and follow all warnings and instructions before installation and use.
- The gate opener must be powered by 2 PCS 12VDC/12Ah batteries (connected in series)
- Never connect solar panel to the control board directly to charge the battery.
- Periodic checks of the opener are required to ensure safe operation.
- Please save this manual for future reference.

Safety Installation Information

1. READ and FOLLOW all instruction.
2. The gate opener is intended for use with Class I vehicular swing gates.
Class I denotes a vehicular gate opener (or system) dwellings, or a garage or parking area associated therewith.
Install the gate opener only when the opener is appropriate for the construction and the usage class of the gate.
3. Gate opening system designers, installers and users must take into account the possible hazards associated with each individual application. Improperly designed, installed or maintained systems can create risks for the user as well as the bystander. Gate system design and installation must reduce public exposure to potential hazards. All exposed pinch points must be eliminated or guarded.
4. A gate opener can create high levels of force during normal operation. Therefore, safety features must be incorporated into every installation. Specific safety features include safety sensors.
5. The gate must be properly installed and work freely in both directions prior to the installation of the gate opener.
6. The gate must be installed in a location so that enough clearance is provided between the gate and adjacent structure when opening and closing to reduce the risk of entrapment. Swinging gates shall not open into public access areas.
7. The opener is intended for use only on gates used for vehicles. Pedestrians must be supplied with a separate access opening. The pedestrian access opening shall be designed to promote pedestrian usage. The pedestrian access shall be located such that persons will not come in contact with the moving vehicular gate.

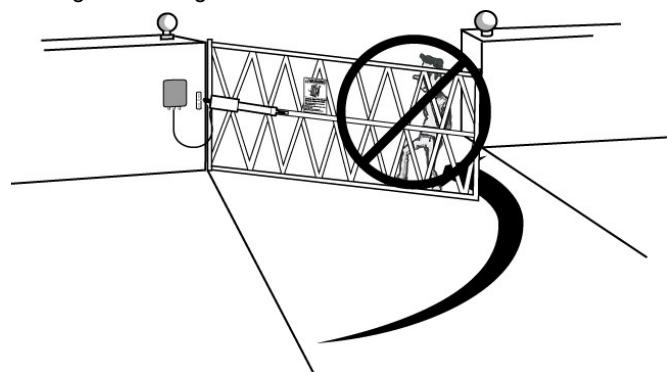

8. Pedestrians should never cross the pathway of a moving gate. The gate opener is not acceptable for use on any pedestrian gate. Pedestrians must be supplied with a separate pedestrian access.
9. For an installation utilizing non-contact sensors (safety sensors), see product manual on the placement of non-contact sensors (safety sensors) for each type of application.
 - a. Care shall be exercised to reduce the risk of nuisance tripping, such as when a vehicle trips the safety sensor while the gate is still moving.
 - b. One or more non-contact sensors (safety sensors) shall be located where the risk of entrapment of obstruction exists, such as the perimeter reachable by a moving gate or barrier.
10. Never mount any device that operates the gate opener where the user can reach over, under, around or through the

gate to operate the controls. Controls are to be placed at least 6' (1.8m) from any part of the moving gate.

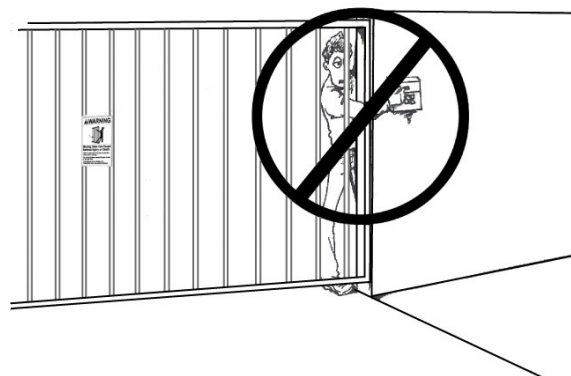

11. Controls intended to be used to reset an operator after 2 sequential activations of the entrapment protection device or devices must be located in the line of sight of the gate, or easily accessible controls shall have a security feature to prevent unauthorized use. Never allow anyone to hang on or ride the gate during the entire travel of the gate.
12. Each gate opener is provided with two safety warning placards. The placards are to be installed on the front and back of the gate where they are plainly visible. The placards may be mounted using cable ties through the four holes provided on each placard.
All warning signs and placards must be installed where visible in the area of the gate.

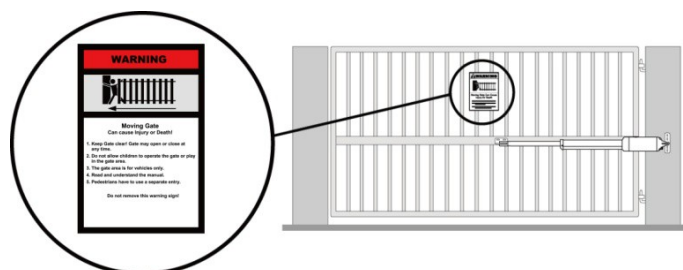

13. To AVOID damaging gas, power, or other underground utility lines, contact underground utility locating companies BEFORE digging.
SAVE INSTRUCTION.

⚠ WARNING

To prevent **SERIOUS INJURY** or **DEATH** from a moving gate:

- Install warning signs on the front and back of the gate in **PLAIN VIEW**.
- Permanently secure each warning sign in a suitable manner using fastening holes.

14. Do not permit children to play on or around the gate and keep all controls out of their reach.

Technical Specifications & Features

Specifications	
Input:	120V/60Hz or 230V/50Hz
Motor voltage:	24VDC
Power:	2 × 80W
Current:	3A
Actuator speed:	16mm/s
Max. actuator travel:	385mm
Ambient Temperature:	-20°C ~ +50°C (-4°F to 122°F)
Protection class:	IP44

Gate Capacity

Gate Weight	380 kg	✓	NR	NR	NR	NR	NR	NR
	340 kg	✓	✓	NR	NR	NR	NR	NR
	300 kg	✓	✓	✓	NR	NR	NR	NR
	250 kg	✓	✓	✓	✓	NR	NR	NR
	200 kg	✓	✓	✓	✓	✓	NR	NR
	160 kg	✓	✓	✓	✓	✓	✓	NR
	110 kg	✓	✓	✓	✓	✓	✓	✓
		1.2-1.8 m	2.4 m	3 m	3.6 m	4.3 m	5 m	5.5 m
Gate Length								

Features:

- Soft start and soft stop
- Emergency release key in case of powerfailure
- Fast selecting push/pull to open
- Stop in case of obstruction during gate opening.
- Reverse in case of obstruction during gate closing.

- Built in adjustable auto-close (0-100 seconds)
- Built in max. Motor running time (MRT) for multiple safety protection (40 seconds)
- Reliable electromagnetism limit for easy adjustment
- Can be equipped with a wide range of accessories

Installation Overview

**Dual Gate Overview
Pull-to-Open Gates**

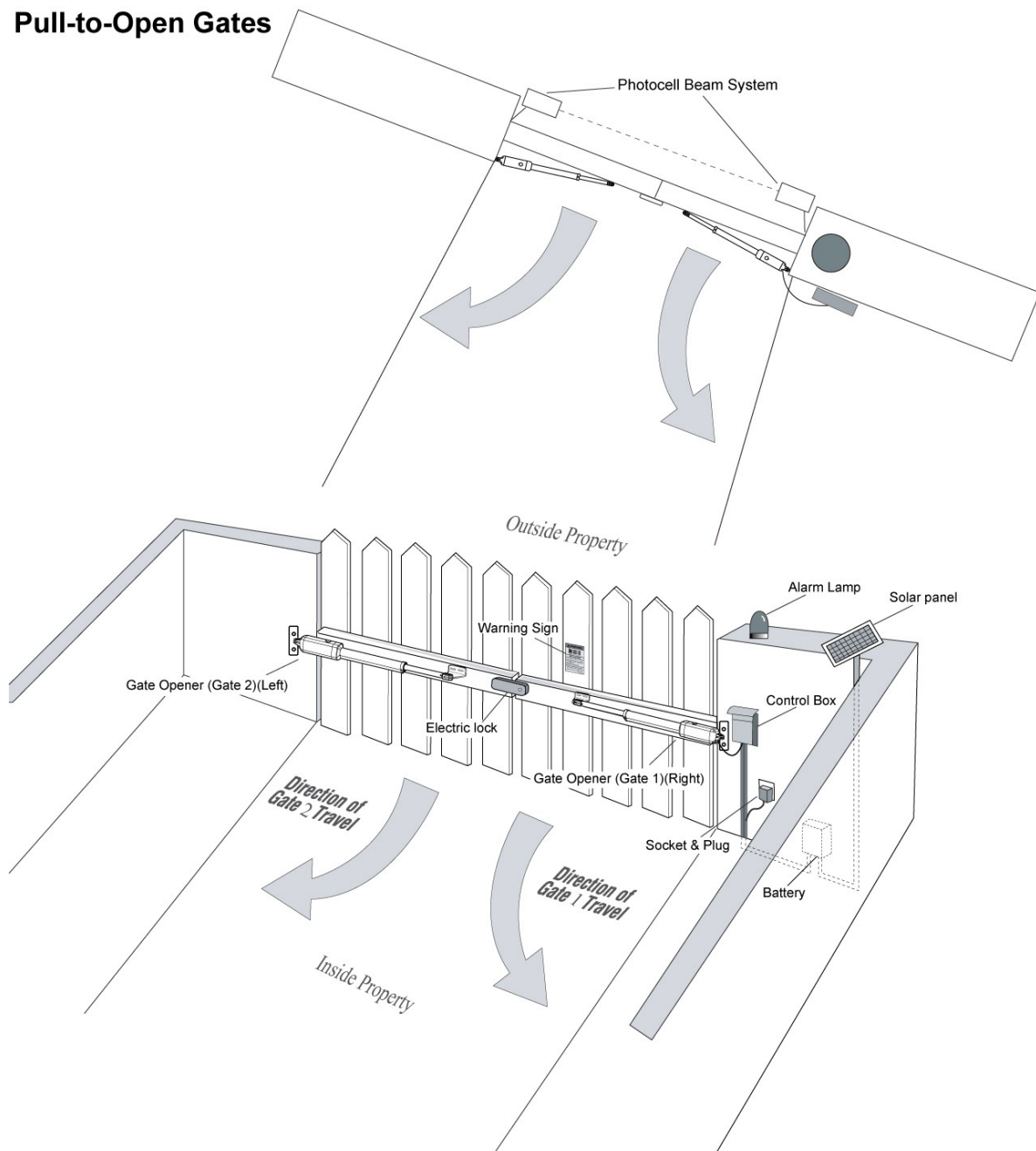

Preparation for Installation

There are two installation types for the gate opener, **Pull-to-Open** and **Push-to-Open**.

In the **Push-to-Open** installation, gate opens out from the property. A Push-To-Open Bracket (**PSO part**) is required to be used for each gate.

NOTE: Ensure the gate does not open into public areas.

The gate opener is mounted to the gate and to the gate post. Both round and square posts can be used because the Post Brackets are curved. When mounting the Post Brackets, use bolts long enough to pass through the entire post. M10 x 200 bolts are included. Concrete anchors are not provided.

When mounting the Post Brackets to wooden posts, a larger-size washer or metal plate should be used between the bolts and the wooden post to ensure the stability of the fastening hardware. If the post is smaller than 6" diameter or square, it should be made of metal and set in cement to ensure its stability.

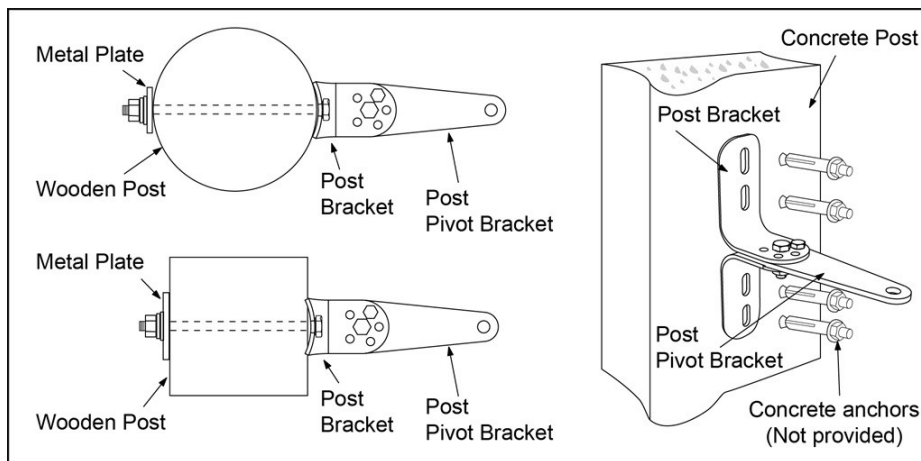

Install the Gate Opener on the Gate

The position of Post Bracket is very important. The following illustrations and tables are required to determine the proper mounting position for the Post Bracket. The tables show the maximum opening angle of the gate for a given A and B. For example, if A is 15cm and B is 20cm, the maximum opening angle of the gate is 110°.

Pull-to-Open Installation — Gate in Closed position (Moving-Rod is extended)

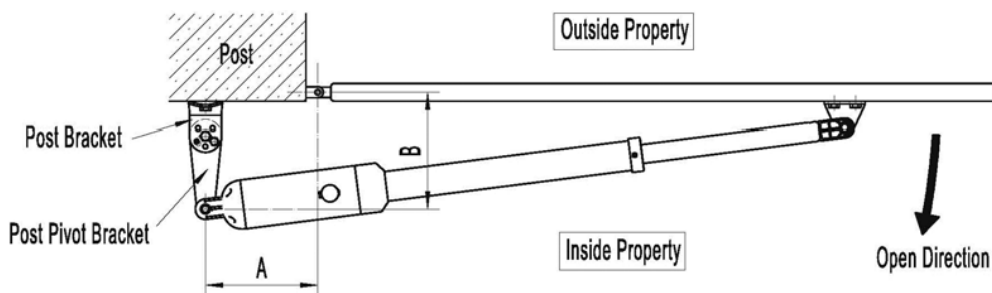

	A=8cm	A=9cm	A=10cm	A=11cm	A=12cm	A=13cm	A=14cm	A=15cm	A=16cm	A=17cm	A=18cm	A=19cm	A=20cm	A=21cm	A=22cm
B=19cm	90°	93°	96°	98°	101°	104°	106°	108°	110°	105°	102°	98°	95°	93°	91°
B=20cm	91°	93°	95°	98°	100°	103°	107°	110°	104°	99°	96°	94°	92°	90°	89°
B=21cm	91°	93°	95°	97°	100°	103°	106°	103°	99°	96°	93°	91°	89°	88°	
B=22cm	91°	94°	95°	97°	99°	101°	103°	98°	95°	92°	90°	89°	87°		
B=23cm	92°	94°	96°	98°	100°	103°	98°	94°	92°	90°	88°	86°			
B=24cm	90°	92°	95°	97°	99°	97°	93°	91°	88°	87°	85°				
B=25cm	90°	92°	94°	97°	96°	92°	90°	87°	85°	84°					
B=26cm	90°	92°	94°	95°	91°	88°	86°	84°							
B=27cm	90°	92°	95°	90°	87°	85°									
B=28cm	90°	93°	89°	86°	84°										

Push-to-Open Installation — Gate in Closed position (Moving-Rod is retracted)

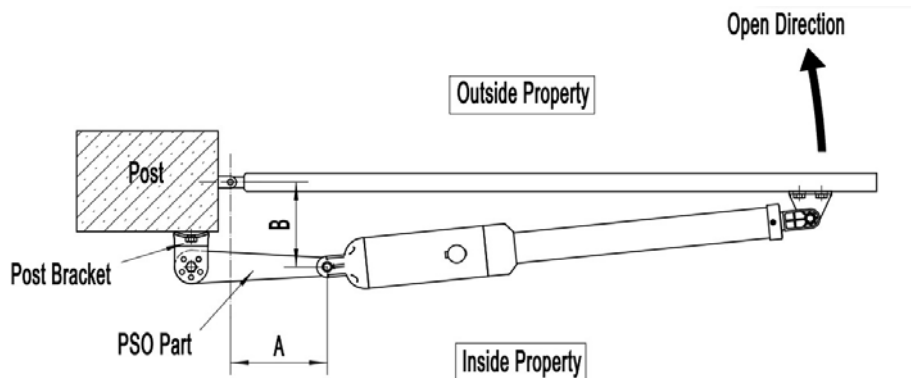

	A=10cm	A=12cm	A=14cm	A=16cm	A=18cm	A=20cm	A=22cm	A=24cm	A=26cm
B=9cm	90°	100°	111°	120°	125°	117°	108°	99°	90°
B=11cm	90°	98°	107°	115°	120°	111°	100°	92°	86°
B=13cm	90°	97°	104°	110°	114°	104°	94°	87°	
B=15cm	90°	98°	105°	112°	109°	97°	89°		
B=17cm	90°	96°	101°	108°	101°	91°	83°		
B=19cm	90°	95°	100°	106°	93°	85°			
B=21cm	90°	94°	99°	97°	87°				
B=23cm	90°	93°	97°	90°	81°				
B=25cm	90°	93°	94°	83°					
B=27cm	90°	92°	86°						

1. Insert the M10 x 30 bolt through the center hole of the post bracket and post pivot bracket as shown. Place a \varnothing 10 washer, \varnothing 10 lock washer and M10 nut on the bottom of the bolt and hand tighten.

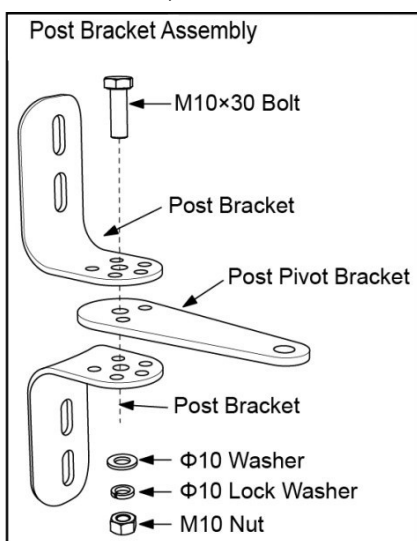

2. Attach the gate bracket and post bracket assembly to the opener by inserting a clevis pin. Secure the clevis pins using the hairpin clips.

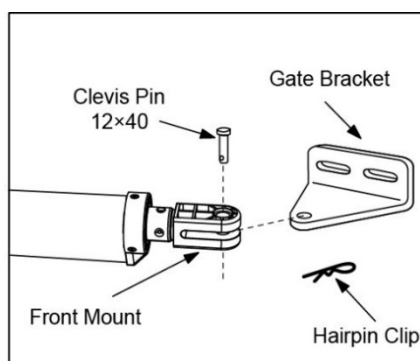
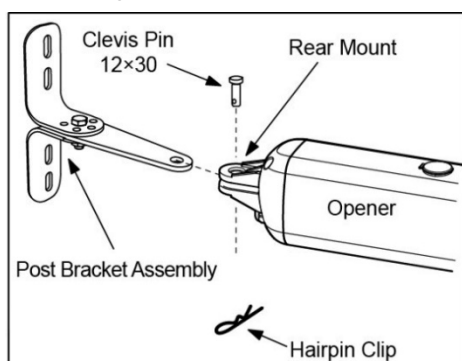

3. Open the release hole plug on the top of the gate opener, insert the release key, and turn the key 90° clockwise. This releases the motor and allows the push-pull rod to be manually extended and retracted. To restore normal operation, turn the key 90° counterclockwise.

4. With the opener fully retracted and with the gate in the fully open position (for Pull-to-Open installation) or fully closed position (for Push-to-Open installation), place the gate opener with the Pos Bracket Assembly and Gate Bracket on the gate post and the gate Position the Post Bracket Assembly and Gate Bracket so that the gate opener is level. While holding the gate opener in the level position, temporarily secure it with two C-clamps.

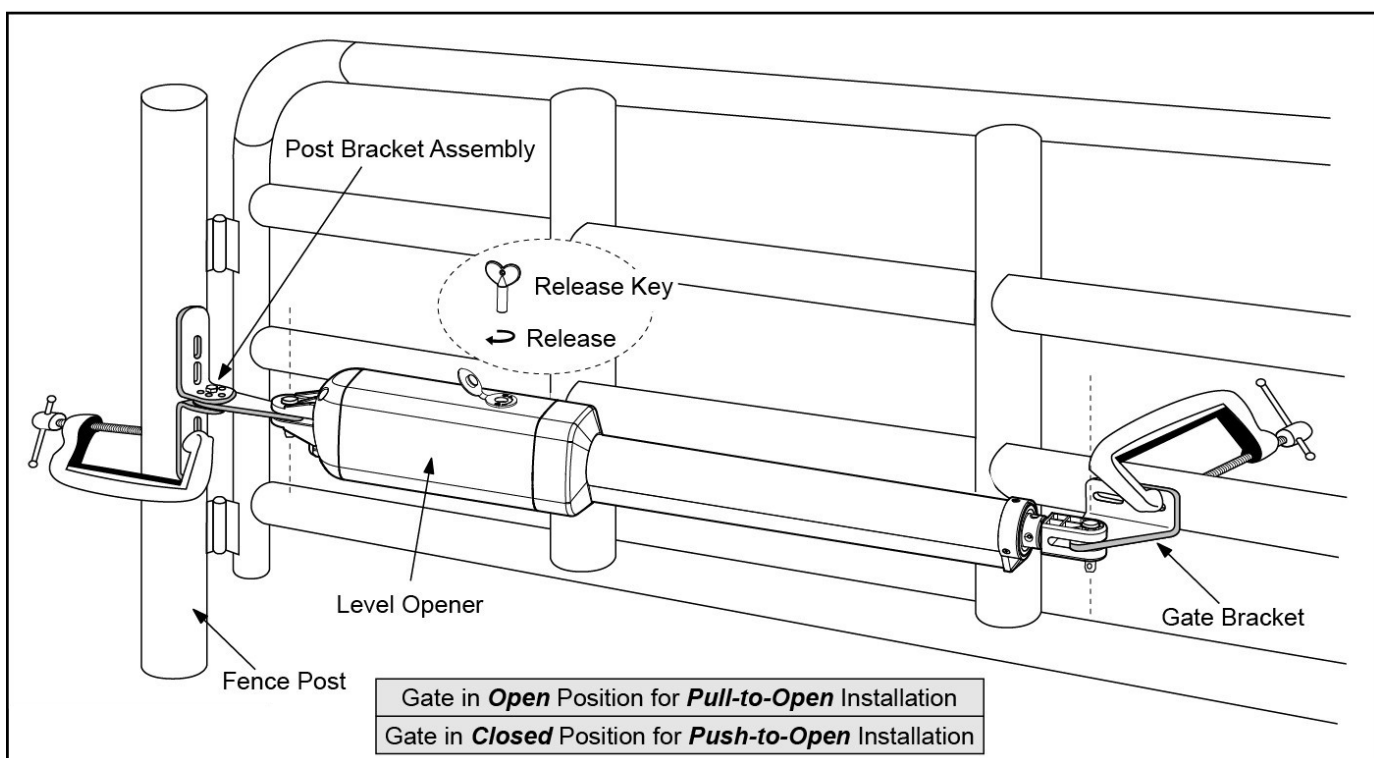
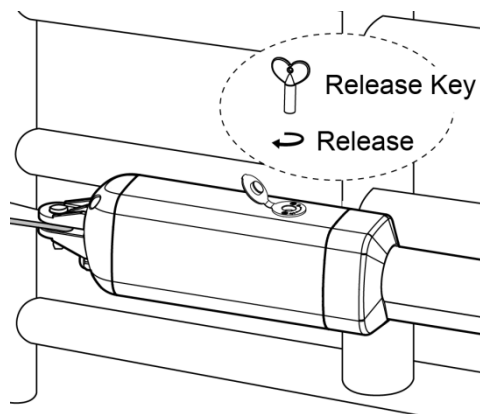

5. Make sure that there is a minimum clearance of 2.5cm between the gate and the opener and that the opener and the Post Pivot Bracket are not binding in both the gate-open and gate-closed positions. If there is not at least 2.5cm of clearance or if the opener and the Post Pivot Bracket are binding, rotate the Post Pivot Bracket and/or move the Post Bracket Assembly to obtain the minimum clearance and eliminate the binding. When the minimum clearance has been obtained and any binding has been eliminated, place the M8 x 30 bolt through the aligned holes in the Post Bracket and the Post Pivot Bracket.

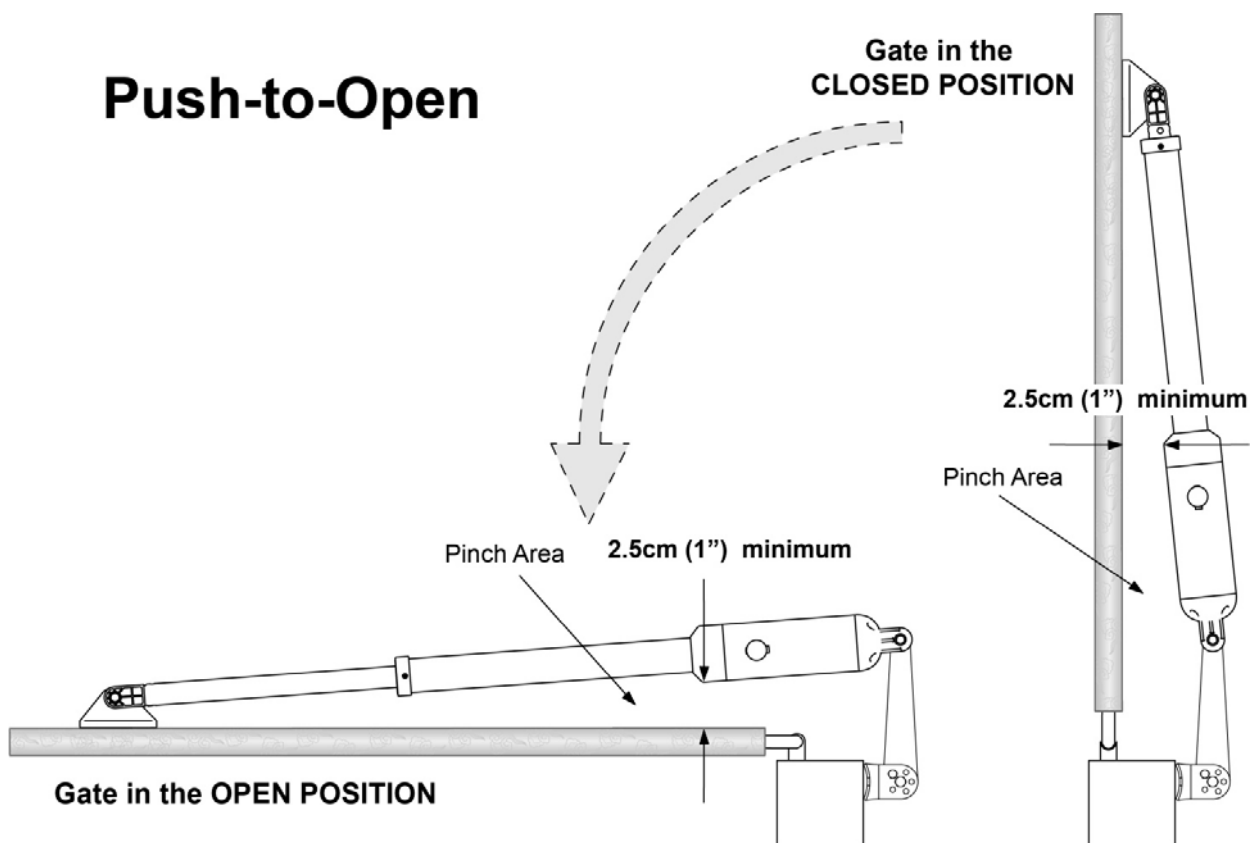
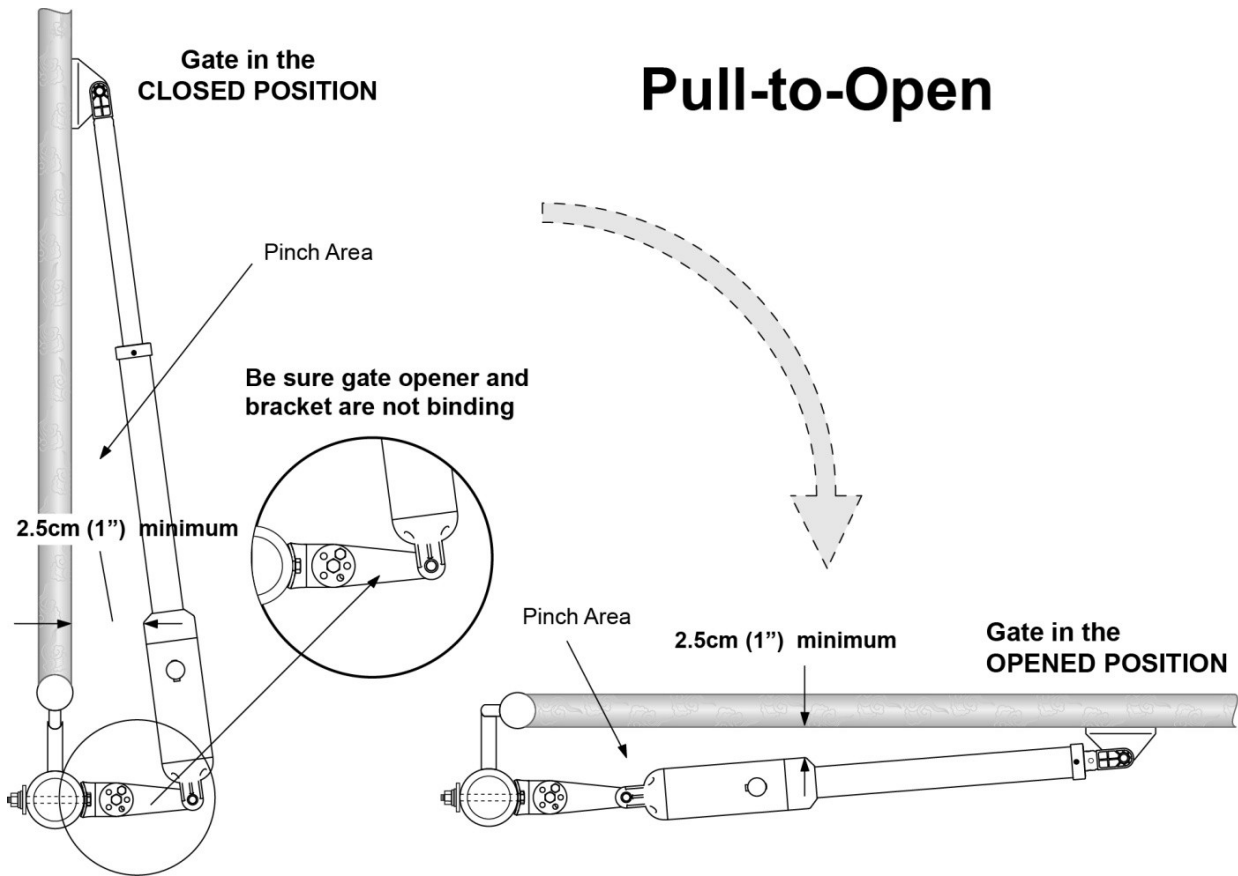

6. Sign the bolt-hole point on the gate bracket and gate. Do this by placing a punch or a sign in the middle of each bolt slot on the post bracket assemblies and the gate bracket. It allows slight adjustments to the post bracket. Then remove the post bracket and gate bracket by taking off the C-clamps.

7. Drill 10.5 mm diameter holes through the post and the gate at the marked locations.

8. Attach the post bracket assemblies to the gate posts by inserting M10 x 200 bolts through each post bracket assembly and the drilled holes in the gate post. Fasten each bolt with one \varnothing 10 washer, one \varnothing 10 lock washer, and one \varnothing 10 nut.

9. Attach the gate brackets to each gate by inserting two M10 x 75 bolts through the gate brackets and the drilled holes in the gates. Fasten each bolt with one \varnothing 10 lock washer, and one \varnothing 10 nut.

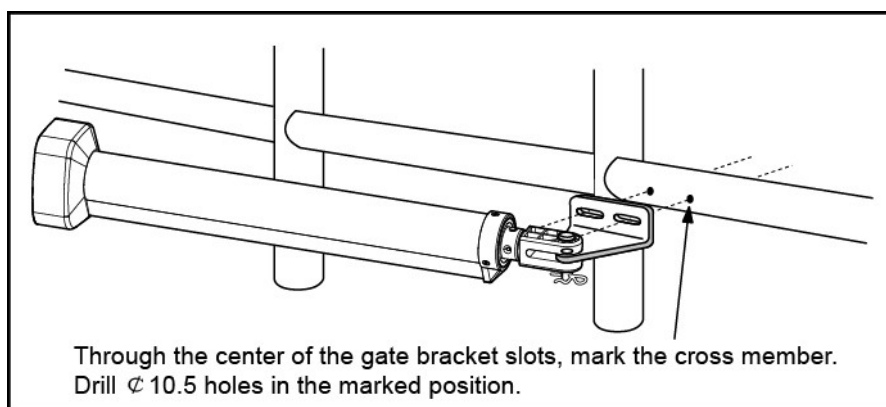
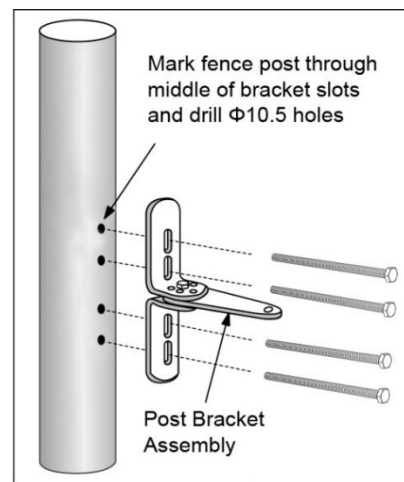

10. Cut off any part of the bolts that extend beyond the tightened nuts.

11. With the gate opener fully retracted and with the gate in the fully open position (for Pull-to-Open installation) or fully closed position (for Push-to-Open installation), attach the gate opener to the Post Bracket Assembly and the Gate Bracket by inserting a clevis pin through the gate opener and the Post Pivot Bracket and another clevis pin through the gate opener and the Gate Bracket. Secure each clevis pin with a hairpin clip.

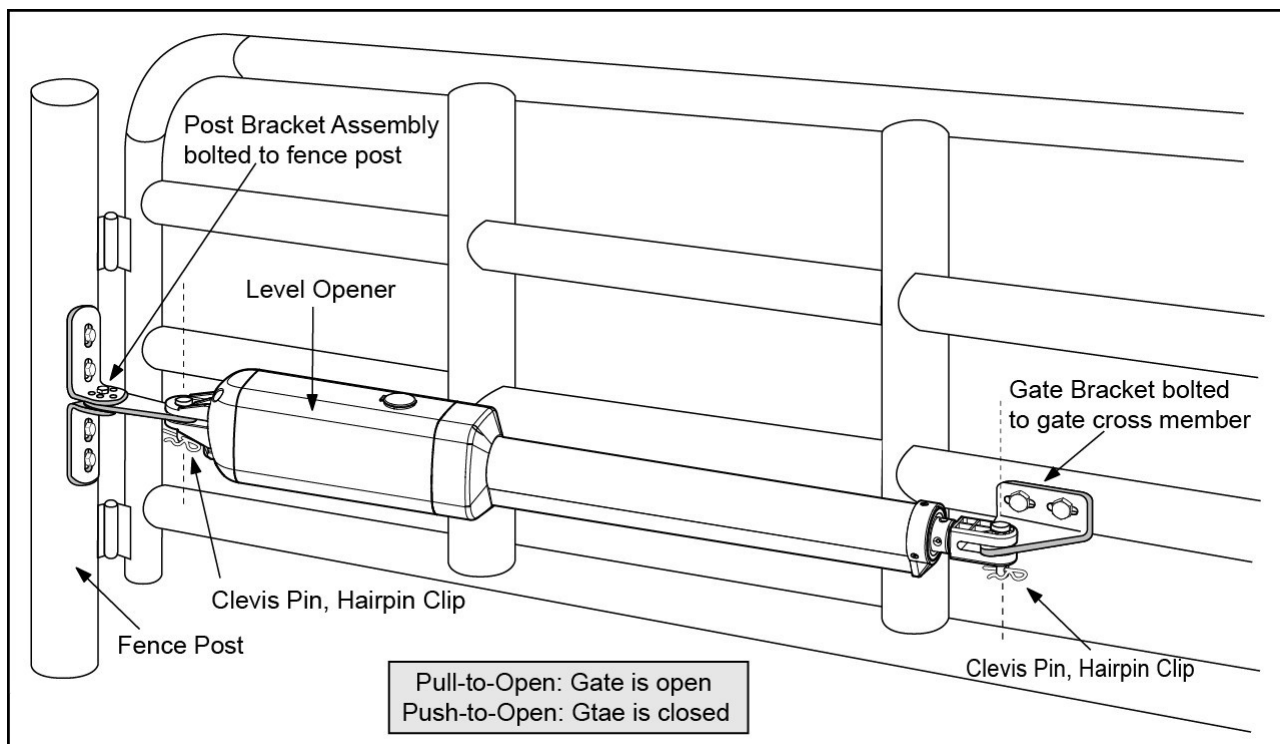

12. Open the release hole plug on the top of the gate opener, insert the release key, and turn the key 90° counterclockwise. This restores normal operation.

NOTE: The setting of the PULL/PUSH TO OPEN of the control board should be in accordance with the installation.

Mounting of the control box

Use 4 deck screws (not provided) to install the control box. Ensure the control box is installed in a secure surface and at least 100 cm (40 inches) above the ground to protect it from rain, snow, etc. which probably cause damage to the control box.



Connection of the power supply

- ⚠** *The gate opener must be powered by 2 PCS 12VDC batteries (connected in series, NOT INCLUDED)*
- ⚠** *If you choose the batteries as the power source, Marine or Automotive Type Battery with capacity greater than 12 AH is required (NOT INCLUDED). 2 PCS 12VDC batteries can be connected in series to become 24VDC to power up the gate opener. The following diagram will show you how to connect 2 PCS batteries in series. Please note the wire connection of the batteries is very important. Incorrect wire connection will damage the control board. The batteries should be waterproof type or you should place them in water proof housing.*
- ⚠** *Please ensure other wire connections are completed before connecting the power supply.*

1. Use the batteries as the power source and only use the solar panel to charge the batteries

If you only use the solar panel to charge the batteries, please note the power of the solar panel should be at least 30W x 24V. The gate opener can work for 10 cycles if there is no other accessory except photocell & electric lock & push button & alarm lamp connected to the control board. The capacity of the batteries and the power of the solar panel should be enlarged if you want to use more. You can connect the solar panel and the solar charge controller refers to the following illustration.

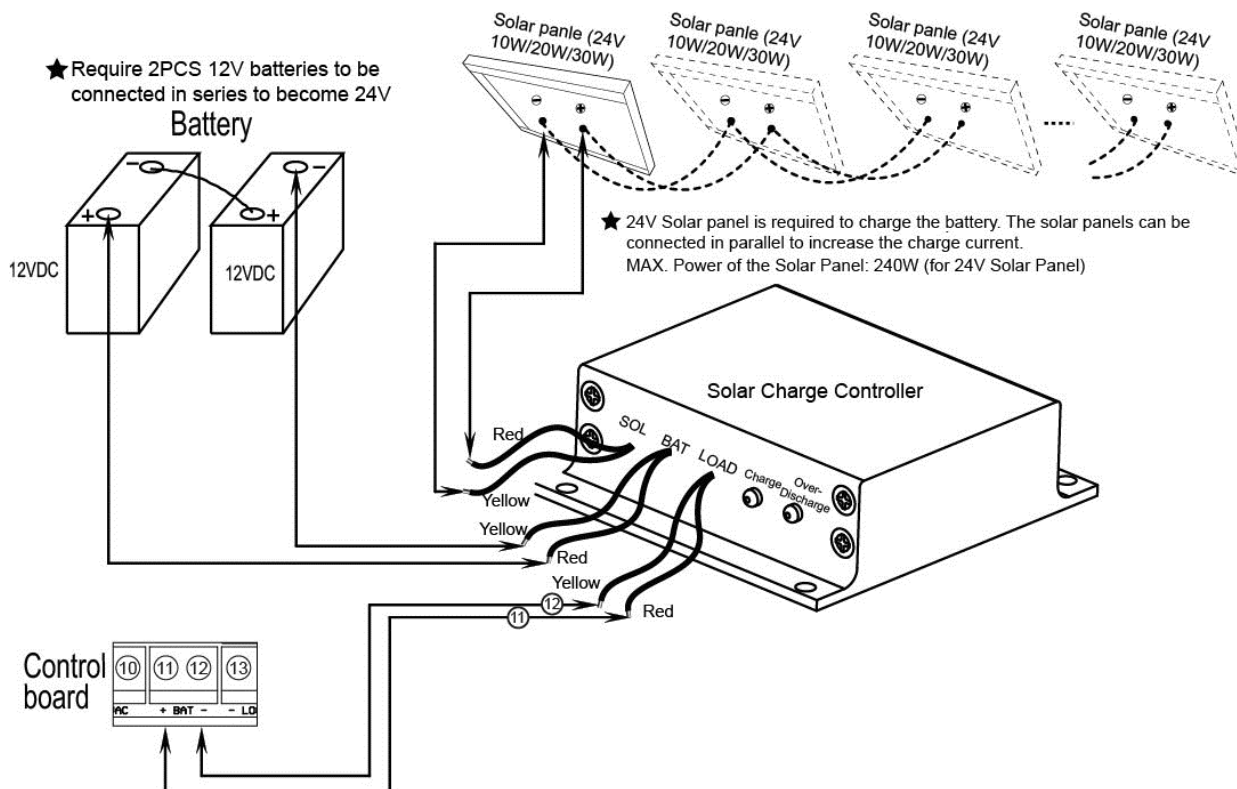

Connection of the control board

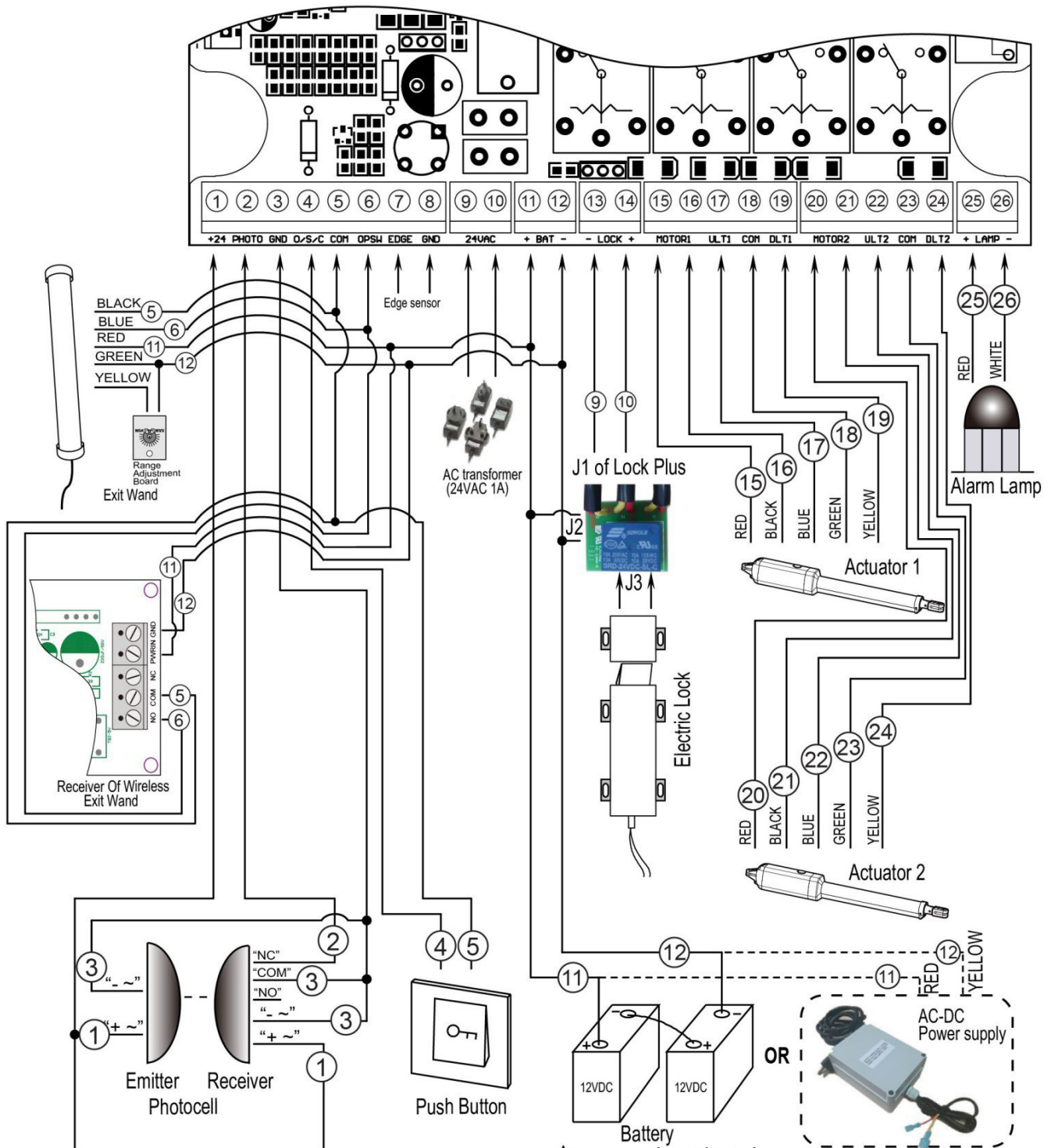

★ 2PCS 12V batteries to be connected in series to become 24V

⚠ Important Note:

2PCS 12V batteries (NOT INCLUDED, at least 12AH) or an AC-DC 24VDC power supply (NOT INCLUDED, Min. output power:150W) is required to power up the gate opener. You can choose the AC-DC power supply to save the cost if the AC electricity is stable. Please note that the AC transformer in the package is only used to charge the batteries. If you use the AC-DC power supply as the power source, it's no need to use the 24VAC/1A transformer in the package.

Cut/remove existing Plug & Play fitting from motor cable.

Strip wires to expose the coloured wires.

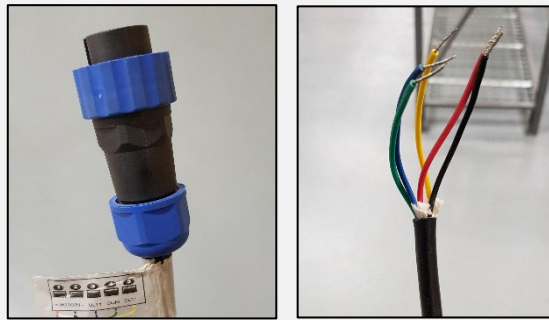

1. Actuator 1 (Master gate, open first & close last)

Insert the stripped cable wires into the appropriate terminals on the opener terminals block. The **red** wire should be inserted into the “**+MOTOR1**” terminal(#15), the **black** wire into “**MOTOR1-**” terminal (#16), the **blue** wire into “**ULMT1**” terminal(#17), the **green** wire into “**COM**” terminal(#18), and the **yellow** wire into “**DLMT1**” terminal (#19).

2. Actuator 2 (Slave gate, close first & open last)

The **red** wire should be inserted into the “**+MOTOR2**” terminal(#20), the **black** wire into “**MOTOR1-**” terminal (#21), the **blue** wire into “**ULMT1**” terminal(#22), the **green** wire into “**COM**” terminal(#23), and the **yellow** wire into “**DLMT1**” terminal (#24).

3. Battery OR AC-DC power supply (Required but not included)

Please connect them refers to the chapter “**Connection of the power supply**”.

4. AC transformer (Only used to charge the batteries)

Insert the stripped cable wires into **AC24V** (#13) terminals to the control board. No matter the polarity. It's no need to use it when you choose the AC-DC power supply as the power source.

5. Alarm Lamp (optional)

The red wire of the alarm lamp should be inserted into either **LAMP** (#25) terminal, the white wire into the other one (#26).

6. Photocell Beam System (PBS) (optional)

Use a 2-core cable to connect the “**+ ~**” terminal of the photocell's emitter to the “**+24**” (#1) terminal, the “**- ~**” terminal to the “**GND**” (#3) terminal. Also the “**+ ~**” and “**- ~**” terminals of the photocell's receiver should be connected to the “**+24**” and “**GND**” terminals in parallel.

Use another 2-core cable to connect the “**NC**” terminal of the receiver to the “**PHOTO**” (#2) terminal, the “**COM**” terminal to the “**GND**” (#3) terminal.

7. Push Button (optional)

The push button should be wired to the “**#4** and “**#5**” terminals. No matter the polarity. The gate operator works alternately by pressing the button (open-stop-close-stop-open).

8. Electric Lock (optional)

A lock plus board is required to connect the electric lock to the control board. The 2 wires of J1 of lock plus should be wired to the “**9#**” and “**10#**” terminal of the control board. No matter the polarity. Red wire of J2 should be wired to the 11# terminal and yellow wire of J2 should be wired to the 12# terminal. Red wire of J3 should be connected to the red wire of electric lock and also the yellow wire of J3 should be connected to the yellow wire of electric lock.

NOTE: If you use the 24VDC AC-DC power supply as the power source and intend to use the electric lock, the open delay time of the 2 actuators should be more than 4S.

9. Exit Wand (optional)

The **BLACK** wire of the exit wand should be connected into the “#5” terminal.

The **BLUE** wire of the exit wand should be connected into the “#6” terminal.

The **RED** wire of the exit wand should be connected into the “#11” terminal.

The **GREEN** wire of the exit wand should be connected into the “#12” terminal.

The sensitivity adjustment board should be wired to the **GREEN** wire and the **YELLOW** wire of the wand. No matter the polarity.

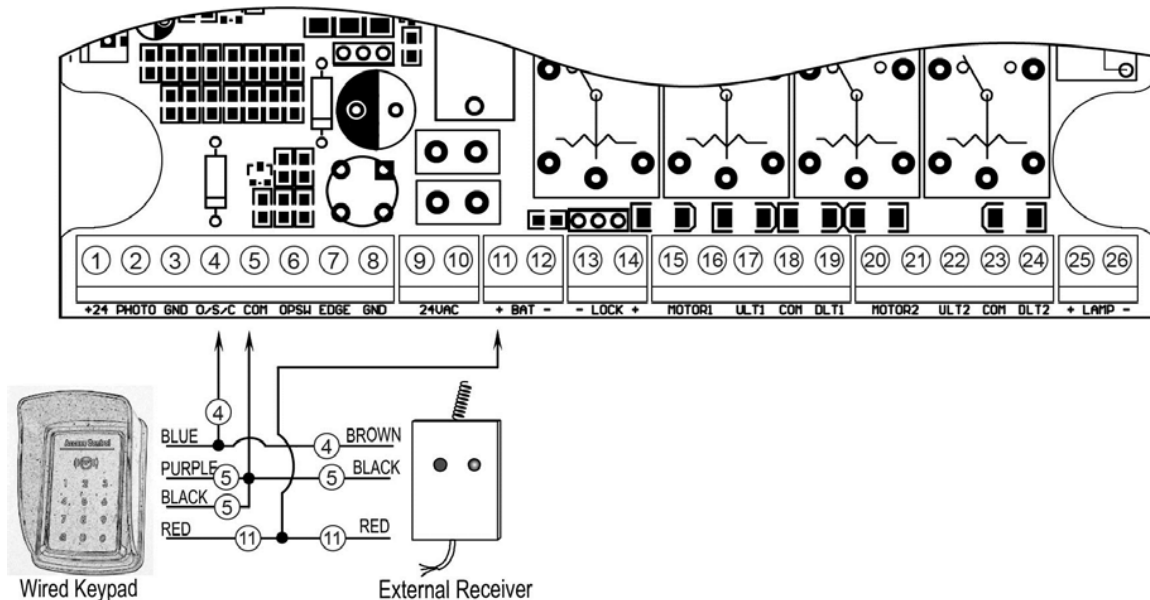

10. Wireless Exit Wand (optional)

The “**NO**” terminal of the receiver should be wired to the “#6” terminal of the control board.

The “**COM**” terminal of the receiver should be wired to the “#5” terminal of the control board.

The “**PWR**” terminal of the receiver should be wired to the “#11” terminal of the control board.

The “**GND**” terminal of the receiver should be wired to the “#12” terminal of the control board.

11. Wired Keypad (optional)

The **RED** wire of the wired keypad should be connected into the “#11” terminal.

The **BLACK** wire of the wired keypad should be connected into the “#5” terminal.

The **PURPLE** wire of the wired keypad should be connected into the “#5” terminal.

The **BLUE** wire of the wired keypad should be connected into the “#4” terminal.

12. External receiver (optional)

The **RED** wire of the external receiver should be connected into the “#11” terminal.

The **BLACK** wire of the external receiver should be connected into the “#5” terminal.

The **BROWN** wire of the external receiver should be connected into the “#4” terminal.

Note: Using of the exit wand, keypad and external receiver would cause the battery exhausted quickly.

Big capacity of battery and big power of solar panel (if the solar panel is used as main charger) is required if you want to use either of them.

How to Program the Remote to the Opener

You must program the remote to the opener before operating. You can follow the below steps to program the remote to the opener.

Press and release the **CODE SW** button, the **CODE LED** will be ON, then press the key in the remote twice in 4 seconds, the **CODE LED** will flash for 3 seconds and then to OFF. Now the remote has been programmed successfully.

NOTE: The button of the remote control should be pressed and hold for more than 2 seconds while programming. Max. 10 remotes can be programmed for the opener. If you want program more remotes, you should use an optional external receiver.

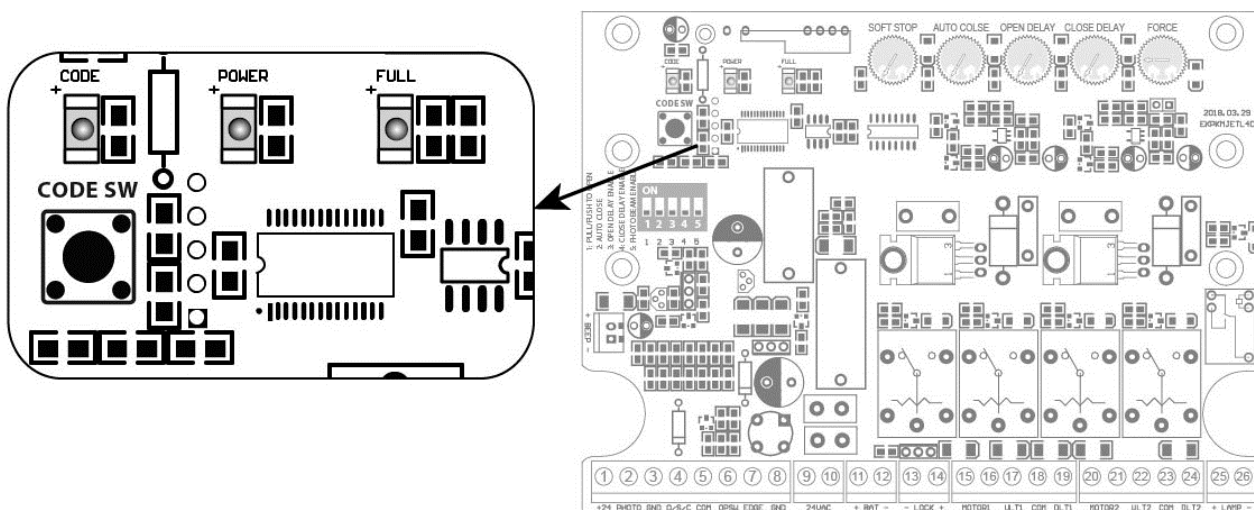

How to Erase All the Remote Codes

Press and hold the **CODE SW** button until the **CODE LED** from ON to OFF. Now all remote codes have been erased.

How to use the remote to operate your gate opener

Each remote has four buttons, from top to bottom are separately A, B, C and D. You may use this remote to operate as many as 4 sets our swing gate opener or 1 set our sliding gate opener and 2 sets our swing gate opener.

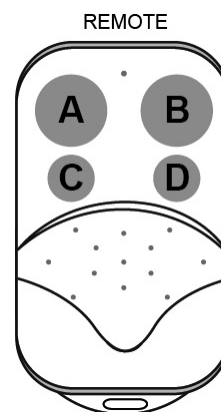

1. Use this remote to only operate our swing gate opener

A,B,C and D four buttons share same function once they are programmed with our swing gate opener. You may choose any button to program it with our swing gate opener. Every press of the button is able to activate the gate opener to work alternately (open-stop-close-stop-open).

2. Use one remote to operate our swing gate opener & sliding gate opener at the same time

All of our sliding gate opener have midway mode. B is designed to realize midway function (refer to more details in our sliding gate opener manual). So it is must program A button with sliding gate opener, while you may program either C button or D button with our swing gate opener.

Wireless keypad programming

You can follow the below steps to program wireless keypad to the opener. Press the **CODE SW** button until the **CODE LED** is ON, and then release the button. Then press "OK" button on keypad and **CODE LED** will flash for 3 seconds and then be OFF which indicates the keypad has been programmed successfully. You can use the default password "888888" to operate the opener after programming. You can press "**PIN**" "8 8 8 8 8 8" and then press "**OK**" to confirm to operate the opener.

Also you can change the password of the keypad follow the below steps. Press "PIN" and then input the six digits old password and then press "PIN" again, the **CODE LED** will be ON. Input the six digits new password and then press the "PIN" to confirm the new setting, **CODE LED** will flash for 3 seconds and then be OFF which indicates the password has been changed successfully. You can press "PIN" "6 digits new password" and then press "OK" to confirm to operate the opener.

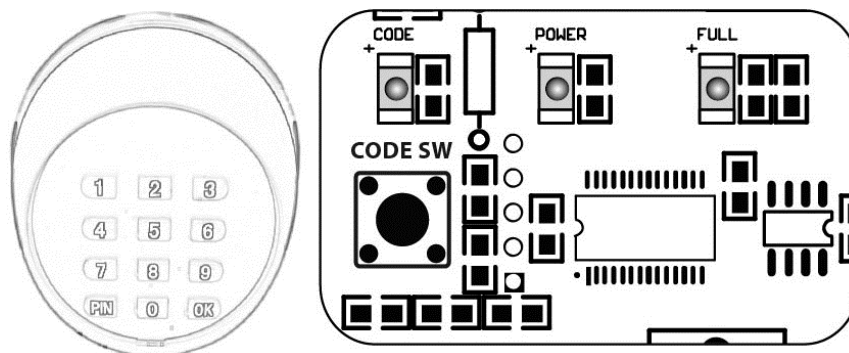

Wireless Keypad

NOTE: Every step for pressing button during program must be finished within 1 second to ensure successful programming.

Setting of the Control Board

⚠ WARNING: Ensure the gate opener is Power Off when you make any adjustment of the gate opener. Keep away from the gate during you set the gate opener system in case of the unexpected gate moving. Carefully adjust the DIP switches to avoid the risk of machine damage and injury or death. Always ask the help of professional technician /electrician if you have any question.

1. DIP Switches

The DIP switches are used to select pull/push to open, enable/disable auto close function, enable/disable open interval between the master and slave gate opener, enable/disable close interval between the master and slave gate opener and enable/disable photo beam function.

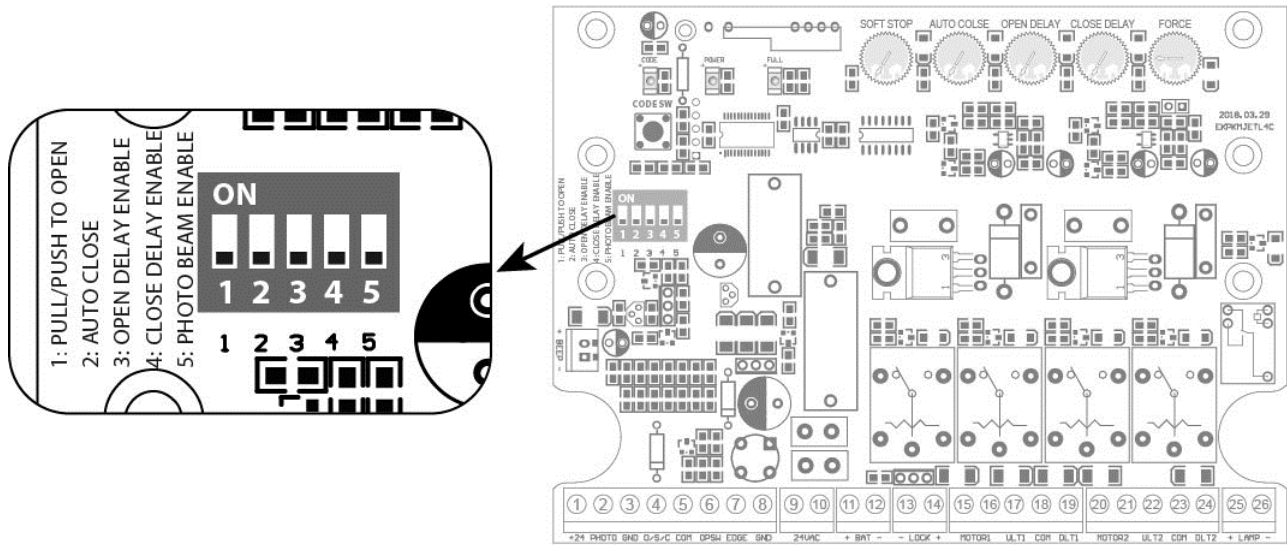

DIP Switch #1: Select push/pull to open

If the gate opens into the property (**pull to open**), the DIP Switch is set to **OFF** (factory default setting). If your gate opens out from the property (**push to open**) the DIP Switch must be set to the **ON** position. Factory default setting is **OFF**.

DIP Switch #2: Auto close function enabled/disabled

ON – Auto close function **enabled**

OFF – Auto close function **disabled**

Set the switch #2 to ON to enable the auto close function. Factory default setting is **OFF**.

DIP Switch #3: Enable/disable open interval between the master and slave gate opener

ON – Open interval is **enabled**

OFF – Open interval is **disabled**

Factory default setting is ON.

NOTE: Open interval time can be adjusted by the **OPEN DELAY** potentiometer.

DIP Switch #4: Enable/disable close interval between the master and slave gate opener

ON – Open interval is **enabled**

OFF – Open interval is **disabled**

Factory default setting is ON.

NOTE: Close interval time can be adjusted by the **CLOSE DELAY** potentiometer.

DIP Switch #5: Photocell function enabled/disabled

ON – Photocell function **enabled**

OFF – Photocell function **disabled**

You must set the switch #5 to ON to enable the photocell function if you want to use the photocell with the gate opener. Factory default setting is **OFF**.

2. Potentiometers

There are 5 potentiometers located in the control board. They are used to adjust soft stop period, auto-close time, open interval and close interval time between master gate opener and slave gate opener, and the stall force.

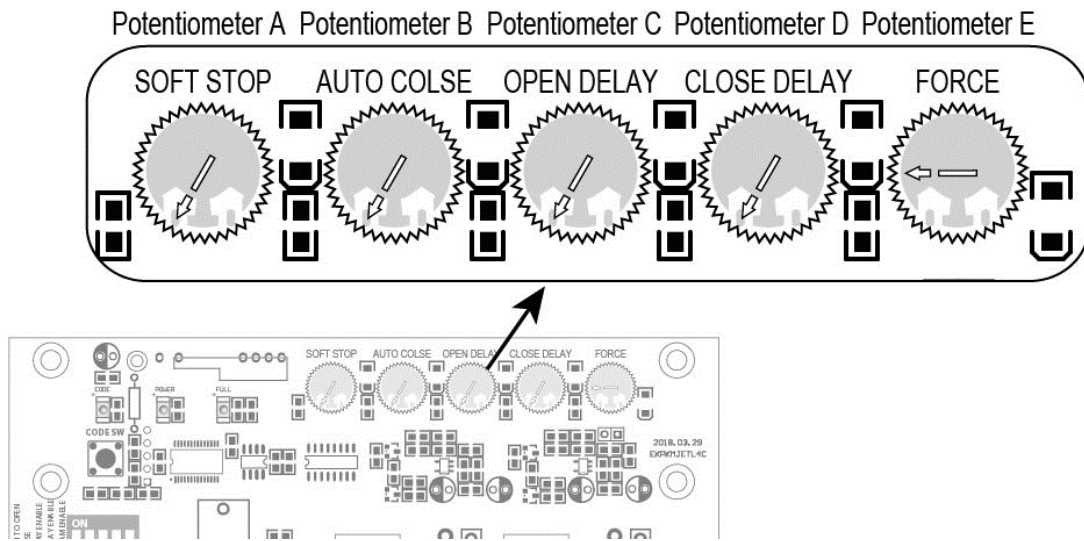

Potentiometer A is used to adjust the soft stop period of the gate opener. Turn the potentiometer clockwise to increase the soft stop period, and turn it counter-clockwise to decrease the soft stop period. The soft stop period can be adjusted steplessly from 1 to 5 seconds.

Potentiometer B is used to adjust the auto close time of the gate opener. Turn the potentiometer clockwise to increase the auto close time, and turn it counter-clockwise to decrease the auto close time. The auto close time can be adjusted steplessly from 3 to 120 seconds.

Potentiometer C and potentiometer D are used to adjust the open interval and close interval time between the master gate opener and the slave gate opener respectively. Turn the potentiometer clockwise to increase the interval time, and turn it counter-clockwise to decrease the interval time. The interval time can be adjusted steplessly from 1 to 9 seconds.

Potentiometer E is used to adjust the stall force the gate opener. Turn the potentiometer clockwise to increase the stall force, and turn it counter-clockwise to decrease the stall force.

Status of LED(s) & Trouble Shooting

Status of gate opener	Status of LED(s)			Possible Solution(s)
	CODE LED	POWER LED	FULL LED	
Standby	OFF	Flash(1 Blink every second)	OFF	Normal (Voltage of the battery is normal)
Running	Flash(1 Blink every second)	Flash(1 Blink every second)	Flash(1 Blink every second)	Normal
Standby	OFF	Flash(1 Blink every second)	Normal ON	Normal (Battery is full)
Both of the gates do not move when operating	OFF	Flash quickly for 3 seconds and then back to OFF	OFF	<ol style="list-style-type: none"> 1. Check the power supply of the gate opener is connected or not. The batteries or a 24Vdc AC/DC power supply must be used to power the gate opener. 2. Check the fuse. 3. Check if the wire connection of the power supply is loosening or not.
Standby	OFF	Flash(1 Blink every 2 seconds)	OFF	Voltage of the battery is low, wait the battery to be charged.
The gate reverse when on the way of opening or closing	Flash(1 Blink every second)	Flash quickly until the gate stop running	Flash(1 Blink every second)	<ol style="list-style-type: none"> 1. Ensure that the gates swing freely without any binding. 2. The stall force is adjusted too small. Turn the Potentiometer E to increase the force. 3. Ensure the photo beam is not blocked when a photocell is used.

Both of the gates do not move when operating	OFF	Flash quickly for 3 seconds and then back to flash slowly(1 Blink every second)	OFF	Voltage of the battery is low, wait the battery to be charged.
Both of the gates do not move when operating	Flash quickly for 3 seconds and then back to OFF	Flash quickly for 3 seconds and then back to flash slowly(1 Blink every second)	OFF	1. Ensure the photo beam is not blocked when a photocell is used. 2. Check if the photocell is defective or not.
Both of the gates do not move when operating	OFF	Flash quickly for 3 seconds and then back to flash slowly(1 Blink every second)	Flash quickly for 3 seconds and then back to OFF	Check if the jumper wire between the EDGE and GND terminal is loosening or not.
The gate stop when on the way of opening or closing	Flash quickly for 10 seconds and then back to OFF	Flash quickly for 10 seconds and then back to flash slowly(1 Blink every second)	OFF	Two sequential photo beam blocked has been detected. Please ensure the photo beam is not blocked.
The gate stops during opening or closing	OFF	Flash quickly for 10 seconds and then back to flash slowly(1 Blink every second)	Flash quickly for 10 seconds and then back to OFF	1. Two sequential contact entrapments have been detected. Please ensure there is no obstacle on the path of opening or closing. 2. Increase the stall force.
Both of the gates do not move when operating	Flash quickly	Flash quickly	Flash quickly	1. Re-power on the gate opener. 2. Replace the control board as necessary.



According to Waste of Electrical and Electronic Equipment (WEEE) directive, WEEE should be separately collected and treated. If at any time in future you need to dispose of this product please do NOT dispose of this product with household waste. Please send this product to WEEE collecting points where available.

