

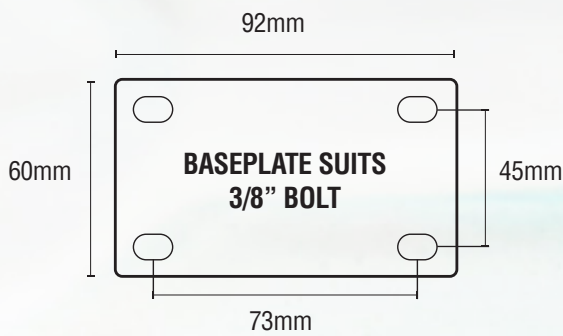

ADJUSTABLE HEIGHT CASTOR

Adjustable from 150mm to 160mm in height using a simple twist motion – Richmond's S75 Adjustable Height Castor is perfect for levelling out equipment on uneven floors, or adjusting to a height that best suits your working needs.

Suitable for loads up to 80kg, this castor is commonly used on kitchen equipment, and is suitable for all kinds commercial kitchen and industrial applications.

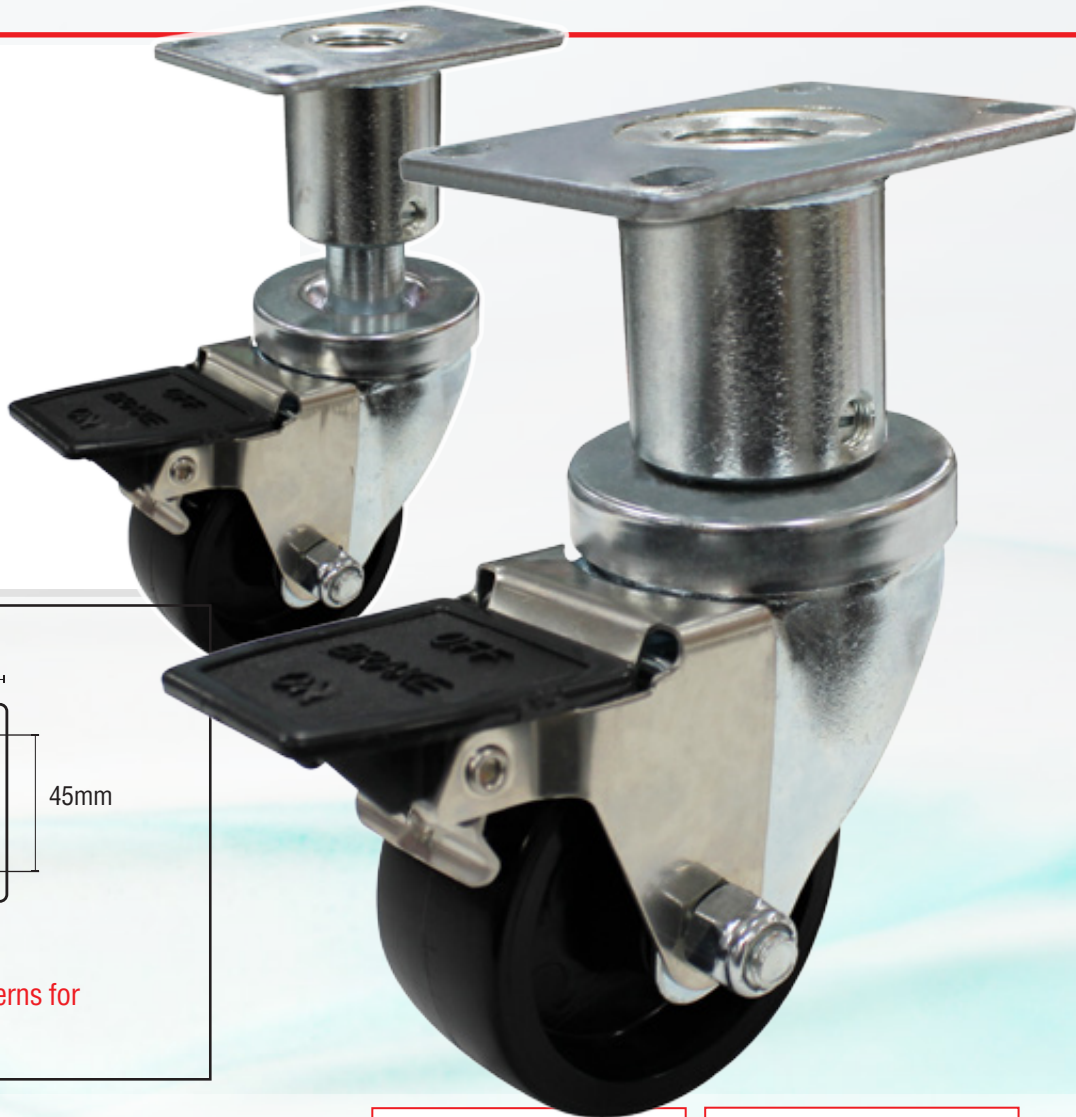









Baseplate dimensions & drilling patterns for adjustable height castor

ADJUSTS FROM 150MM TO 160MM IN HEIGHT

Using a simple twist motion the castor can be adjusted to a new height, where it can then be locked in place.



 Diameter (mm)	 Width (mm)	 Wheel Type	 Bearing Type	 Load Capacity	 Lowered Height (mm)	 Max Adjusted Height (mm)	 Part Number
75	33	Nylon	Plain	80	150	170	S75B