

styleR CASTORS

UP TO 95KG / CASTOR











The styleR range of castors are perfect for light duty applications that require your castors to be the star of the show.

Featuring a bright chrome finish, these clear wheel polyurethane castors can hold up to 95kg each, making them ideal for use at home, in the office or in the hospitality industry. Non-marking wheels ensure that soft and timber floors are not damaged.



S2032

SPECIFICATIONS & FITTINGS - PLATE TYPE

 Diameter (mm)	 Width (mm)	 Wheel Type	 Wheel Code	 Bearing Type	 Load Capacity	 Height (mm)	 Swivel Radius (mm)	 With Brake (mm)	 Swivel Code
50	20	PU/Clear	N/A	Plain	40kg	65	42	55	S2032
75	23	PU/Clear	N/A	Plain	80kg	100	60	75	S3044
100	25	PU/Clear	N/A	Plain	95kg	125	80	85	S4242

To order castor with brake add B to the end of the swivel code, eg. S2032B indicates brake castor. *Wheel brake only

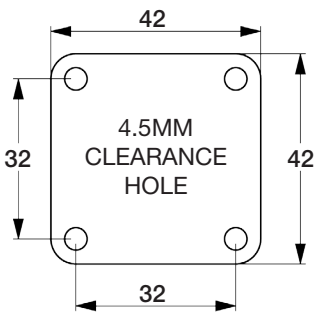

50mm swivel castor

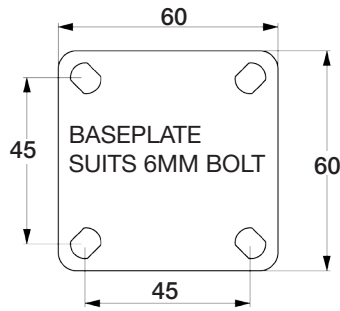

75mm & 100mm swivel castor













S3044B



S3042B

SPECIFICATIONS & FITTINGS - BOLT TYPE

 Diameter (mm)	 Width (mm)	 Wheel Type	 Wheel Code	 Bearing Type	 Load Capacity	 Height (mm)	 Swivel Radius (mm)	 With Brake (mm)	 Thread Size (mm)	 Swivel Code
50	20	PU/Clear	N/A	Plain	40kg	67	42	55	M10x15	S2030
75	23	PU/Clear	N/A	Plain	80kg	100	60	75	M10x15	S3042

To order castor with brake add B to the end of the swivel code, eg. S2030B indicates brake castor. *Wheel brake only