

1000 SERIES CASTORS

UP TO 1000KG / CASTOR

The 1000 Series 1000kg load rating provides an economical alternative to heavier load bearing castors. The ability to be towed at a 6kph by tugs and tractors enables this castor to be used on mobile platforms, aviation trolleys, automotive assembly lines and production manufacturing plants.











The polyurethane cast iron wheel type with a rolling diameter of up to 300mm not only enhances maneuverability but decreases rolling resistance. Like most Richmond heavy duty castors, our 1000 series has a precision machined ball race and high tensile steel kingpin to withstand side impact loads.



MOUNTING PLATES AVAILABLE IF REQUIRED
page 95

S6338SLB

SPECIFICATIONS & FITTINGS

 Diameter (mm)	 Width (mm)	 Wheel Type	 Wheel Code	 Bearing Type	 Load Capacity	 Height (mm)	 Swivel Radius	 Rigid Code	 Swivel Code
150	50	Poly Ci	PU659	Ball	900/700	194	130	R6339	S6338
150	45	Cast Iron	Ci601	Ball	1000/500	194	130	R6319	S6318
200	50	Poly Ci	PU876	Ball	1000/750	248	155	R8069	S8068
200	50	Cast Iron	Ci852	Ball	1000/500	248	155	R8089	S8088
250	50	Poly Ci	PU1056	Ball	1000/750	300	180	R1020	S1019
300	50	Poly Ci	PU1218	Ball	1000/750	360	215	R1205	S1204

To order castor with Brake and/ or 4 Way Directional Lock, add B and/or D to the end of Swivel Code e.g. S6138B indicates a brake castor.  denotes towable castors. Also available with Swivel Lock and Brake add SLB to the end of the Swivel Code e.g. S6138SLB.

BASEPLATE DIMENSIONS & DRILLING PATTERNS FOR 1000 SERIES CASTORS

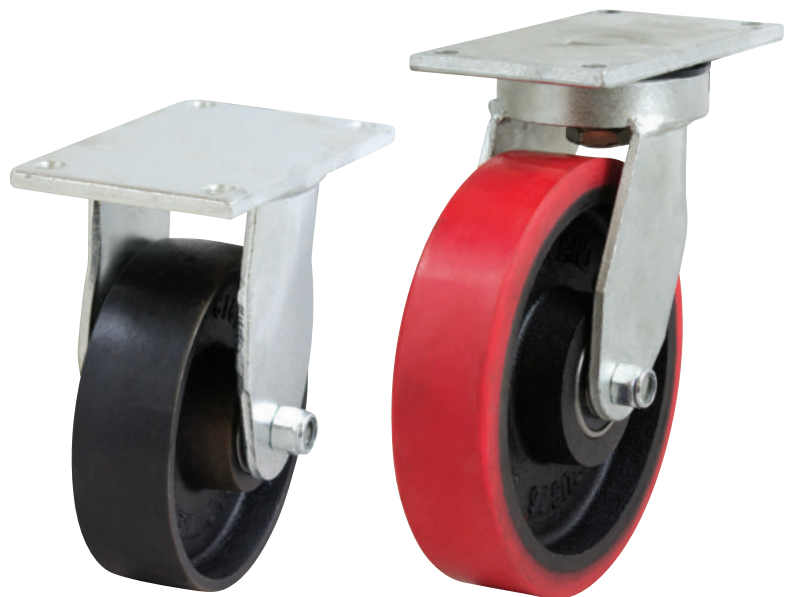
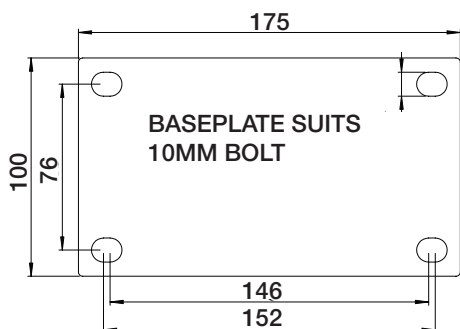

R6319

S1019